

12

**MOUNT POLLEY MINING CORPORATION  
MOUNT POLLEY MINE  
TAILINGS STORAGE FACILITY  
OPERATION, MAINTENANCE AND SURVEILLANCE  
MANUAL**

MP00030

Rev. No.	Revision	Date	Approved
0	Issued in Final	December 22, 2004	
1	Issued in Final	February 06, 2006	RM
2	Issued in Final	March 31, 2006	RM
3	Issued in Final	August 28, 2006	RM

GRIT 4190

MOUNT POLLEY MINING CORPORATION  
MOUNT POLLEY MINE  
TAILINGS STORAGE FACILITY

OPERATION, MAINTENANCE AND SURVEILLANCE MANUAL  
(REF. NO. VA101-00001/9-1)

TABLE OF CONTENTS

	PAGE
SECTION 1.0 - INTRODUCTION .....	1
1.1 OVERVIEW .....	1
1.2 KEY PERSONNEL AND RESPONSIBILITIES .....	1
1.3 TRAINING REQUIREMENTS .....	1
1.4 DESIGN AND OPERATING CHANGES .....	1
1.5 CONTROL OF THIS MANUAL.....	2
1.6 REVISIONS TO THE MANUAL.....	2
1.7 REFERENCES .....	2
SECTION 2.0 - DESCRIPTION OF TAILINGS IMPOUNDMENT .....	3
2.1 GENERAL.....	3
2.2 DESIGN BASIS .....	3
2.3 PROJECT DESCRIPTION .....	3
2.3.1 Site Location .....	3
2.3.2 Project History .....	4
2.4 DESIGN FEATUES .....	4
2.5 DEPOSITION PLAN .....	4
2.6 CLOSURE PLAN.....	5
SECTION 3.0 - OPERATIONS MAINTENANCE AND SURVEILLANCE.....	6
3.1 GENERAL.....	6
3.2 TAILINGS BASIN .....	6
3.3 TAILINGS POND.....	7
3.3.1 Pond Level Operations .....	7
3.3.2 Surveillance .....	7
3.4 TAILINGS EMBANKMENT.....	8
3.4.1 Components .....	8
3.4.2 Surveillance and Maintenance .....	8
3.5 TAILINGS DISCHARGE PIPELINE.....	9
3.5.1 Components and Operation .....	9
3.5.2 Surveillance and Maintenance .....	10
3.6 RECLAIM PIPELINE .....	10
3.6.1 Components and Operation .....	10
3.6.2 Surveillance and Maintenance .....	11
3.7 SEDIMENT PONDS .....	11

3.7.1	Components and Operation .....	11
3.7.2	Surveillance and Maintenance .....	12
3.8	SEEPAGE COLLECTION PONDS.....	13
3.8.1	Components and Operation .....	13
3.8.2	Surveillance and Maintenance .....	13
3.9	INSTRUMENTATION .....	14
3.9.1	Components and Location.....	14
3.9.2	Surveillance and Maintenance .....	15
SECTION 4.0 - SAFETY INSPECTIONS AND REVIEWS .....		16
4.1	ANNUAL INSPECTIONS.....	16
4.2	DAM SAFETY REVIEW .....	16
SECTION 5.0 - EMERGENCY PREPAREDNESS AND RESPONSE PLANS .....		18
5.1	GENERAL.....	18
5.2	WARNING SIGNS .....	18
5.3	INCIDENT NOTIFICATION PROCEDURES.....	20
SECTION 6.0 - CERTIFICATION .....		21

## TABLES

Table 1.1 Rev 0	Personnel and Responsibilities List
Table 2.1 Rev 0	TSF Design Criteria
Table 3.1 Rev 0	Inspection and Surveillance Schedule
Table 3.2 Rev 0	Unusual Events and Occurrences requiring Non-Routine Walkovers
Table 3.3 Rev 0	Summary of Vibrating Wire Piezometers and Trigger Levels
Table 3.4 Rev 0	Summary of Slope Inclinometers and Trigger Levels
Table 3.5 Rev 0	Trigger Levels for Survey Monuments
Table 5.1 Rev 0	Emergency Warning Levels and Required Actions

## FIGURES

Figure 2.1 Rev 0	Project Location Plan
Figure 2.2 Rev 0	TSF Bathymetric Survey
Figure 3.1 Rev 0	Filling Schedule and Staged Construction – 18,500 tpd
Figure 3.2 Rev 0	Groundwater Monitoring Well Locations

## APPENDICES

APPENDIX A	References
APPENDIX B	Tailings Storage Facility – Inspection Log
APPENDIX C	Tailings Storage Facility – Instrumentation Data Sheets
APPENDIX D	TSF Stage 4 As-Built Drawings (in progress)
APPENDIX E	Selected photos of TSF components

**MOUNT POLLEY MINING CORPORATION  
MOUNT POLLEY MINE  
TAILINGS STORAGE FACILITY**

**OPERATION, MAINTENANCE AND SURVEILLANCE MANUAL**

**SECTION 1.0 - INTRODUCTION**

**1.1 OVERVIEW**

This Operations, Maintenance and Surveillance Manual applies to the Tailings Storage Facility and related pipelines and structures at the Mount Polley Mine. This Manual describes the roles and responsibilities of Mount Polley site personnel for the management of the TSF and associated facilities; operation, surveillance and maintenance requirements; inspection requirements; and emergency plans and procedures.

**1.2 KEY PERSONNEL AND RESPONSIBILITIES**

Table 1.1 identifies current key personnel (August 2006) and their responsibilities for management, operations, surveillance and inspections at the Mount Polley Mine Site and Tailings Storage Facility.

Government agencies involved in the operation, maintenance and surveillance of the Tailings Storage Facility include the Ministry of Energy and Mines (MEM); Ministry of Environment (MOE), Ministry of Forests (MOF); and Department of Fisheries and Oceans (DFO).

**1.3 TRAINING REQUIREMENTS**

Training programs are required for any personnel involved in the operation, inspection and surveillance of the Tailings Storage Facility. A refresher course is required once per year. The training programs must be conducted by the Environmental Superintendent, qualified Professional Engineer or a suitably qualified individual familiar with the design, operation, maintenance and inspection of all civil and mechanical works associated with the facility.

Each training session must be documented, and a record kept. The records will contain a detailed list of site activities for which the trainee was trained on, and be signed by the person who provided/supervised the training.

**1.4 DESIGN AND OPERATING CHANGES**

Changes to the design or operating plan for the Tailings Storage Facility and related pipelines and structures must be reviewed, approved and documented. Design changes may be submitted to the Engineer of Record for review. Operational changes will be reviewed and approved by the Mine Manager. In all cases, documentation of the change, including as-built records, are required.

## 1.5 CONTROL OF THIS MANUAL

This manual will be controlled by the Environmental Superintendent. Copies will be maintained at the following locations:

- One (1) copy for Mount Polley Mining Corporation (Vancouver office),
- One (1) copy for the Environmental Superintendent's office,
- One (1) copy for the Operating Crew (Mill Shifter's Office),
- One (1) copy for the Regional Water Manager (Williams Lake),
- Two (2) copies for the Director of the Provincial Emergency Program (P.E.P.),
- One (1) copy for the MOE, Dam Safety Engineer,
- One (1) copy for the MEM Geotechnical Manager,
- One (1) copy for the Design Engineer of Record.

Mount Polley Mining Corporation is responsible for maintaining a record of the location of each copy of the Manual and to ensure the copies in these locations are kept up to date.

## 1.6 REVISIONS TO THE MANUAL

Reviews of the Manual are conducted at least annually.

The operating procedures and personnel at the Mount Polley Mine may change during the operation of the mine. It is the responsibility of the Environmental Superintendent to ensure that the Operations, Maintenance and Surveillance Manual is updated to reflect these changes. Substantial revisions to the Manual shall be submitted to the Ministry of Energy and Mines.

A letter of transmittal that clearly identifies the distribution list must accompany each revision of this manual. An update may comprise the entire manual or be limited to specific pages or sections. A copy of each transmittal letter must be kept on record in the office of the Environmental Superintendent. Each revised page of the manual must be clearly marked as to the revision date prior to replacement. The replaced pages must be filed and kept on record in the office of the Environmental Superintendent.

## 1.7 REFERENCES

References relating to MPMC's Tailings Storage Facility and associated pipelines and facilities are included in Appendix A.

## SECTION 2.0 - DESCRIPTION OF TAILINGS IMPOUNDMENT

### 2.1 GENERAL

The following sections provide a brief summary of the design and management of the Tailings Storage Facility and associated facilities. Additional information is available in the cited references in Appendix A.

### 2.2 DESIGN BASIS

Mill tailings are discharged as slurry into the Tailings Storage Facility which has been designed to provide environmentally secure storage of the solid waste. As the solids settle out of the slurry, process fluids are collected and recycled back to the mill for re-use in the milling process. There is no surface discharge of any process solution from the Tailings Storage Facility. The basis of design must address the following:

- Permanent, secure and total confinement of all solid waste materials within a lined engineered impoundment,
- Secure and reliable transportation of the tailings from the mill to the Tailings Storage Facility,
- Collection and transport of runoff from waste rock storage areas to the Tailings Storage Facility,
- Temporary storage of supernatant water on the tailings beach, as required, with maximum recycling to the mill to produce a zero discharge condition for process water,
- Collection of all free draining liquids from the tailings deposit. Temporary storage is provided in lined external ponds. The water from the ponds is pumped into the supernatant pond and recycled to the mill to ensure that no discharges occur,
- Inclusion of monitoring facilities in the Tailings Storage Facility to confirm that the design objectives and operating requirements are being met,
- Staged development of the facility to enable modifications and upgrades to be implemented based on operating experiences and to distribute the capital expenditures over the life of the project.

The design basis and operating criteria for the Tailings Storage Facility and associated pipelines and structures are summarized in Table 2.1.

### 2.3 PROJECT DESCRIPTION

#### 2.3.1 Site Location

The location of the Mine and access roads are shown on Figure 2.1. The Mount Polley Mine is located in central British Columbia, approximately 60 km northeast of Williams Lake. The main access route is via Likely Road. The turn to the Mine is located approximately 1.5 km east of Morehead Lake. The Mine is located a further 11 km to the southeast, on the Bootjack Lake Forest Service Road.

The Tailings Storage Facility is accessible along the following two routes:

- Along the access road located on the south side of the Mill Site. This is the primary access to the TSF on the Mine site;
- Along the Gavin Lake Forest Service Road which can be access from Likely Road, located approximately 14 km south of Moorhead Lake. The TSF is located at approximately kilometre 16 along the road.

### 2.3.2 Project History

The Mount Polley mine commenced production in June 13, 1997. Ore is crushed and processed by selective flotation to produce a copper-gold concentrate. The mine was on care and maintenance status from October 2001 to February 2005. The mill throughput rate is approximately 18,500 tonnes per day (approx. 6.8 million tonnes per year). Mill tailings are discharged as slurry into the Tailings Storage Facility located on the south area of the Mine property. Additional historic information regarding the TSF and associated pipelines and facilities are available in the reports cited in Appendix A.

## 2.4 DESIGN FEATUES

Tailings slurry is conveyed from the Concentrator to the TSF via a tailings discharge pipeline. The tailings is deposited into the impoundment through moveable or fixed spigots on the embankment crest. A floating reclaim pump recycles process water from the supernatant pond in the TSF for use in the mill processing circuit. Sediment ponds and seepage collection ponds are designed to intercept runoff from the surface and seepage from the embankment respectively. Drains, instrumentation and monitoring wells are constructed in and around the TSF to assist in monitoring the performance of the facility. Additional details are available in the reports referenced in Appendix A. As-built drawings for the latest construction program are included in Appendix D.

## 2.5 DEPOSITION PLAN

The objectives of the long-term tailings deposition strategy is to:

- Maximize the storage capacity of the facility.
- Maintain the supernatant pond in the area of the reclaim barge so as to maximize the amount of clean process water available for reclaim.
- Establish free draining tailings beaches adjacent to the embankments during the winter season to facilitate future embankment raises and to enhance embankment stability.

The above strategy is implemented by sequentially rotating the tailings discharge point along the entire length of the Perimeter, Main and South embankments on the upstream face, which allows inactive areas of the tailings beach to partially dry and consolidate. Eventually, beaches will be formed around the entire upstream perimeter of the Facility and all supernatant water will be centralized around the reclaim barge.



Spigoted tailings settle in the tailings facility and form beaches with three distinct slopes. A sandy beach develops as the coarser tailings fraction settles more rapidly adjacent to the embankment. The average beach slope above water is about 0.5 percent. As the tailings flow into the supernatant pond it forms a submerged beach with a slope of 1 to 2 percent. Finer tailings particles are transported further out into the supernatant pond before settling at a slope of about 0.3 percent. The latest bathymetric survey of the tailings surface in the TSF is included in Figure 2.2.

## 2.6 CLOSURE PLAN

At closure of the Tailings Storage Facility, it is currently envisaged that the tailings surface will be decommissioned so as to develop a mixed forested/wetlands complex with a gradual transition towards a ponded area at the final spillway. This would require covering of the tailings embankments and the upland portions of the exposed tailings beach with a layer of soil stockpiled during operations. The topsoil would be revegetated with indigenous species of conifer and deciduous trees, willow and marsh land grasses. Ultimately, all water would be routed over the tailings surface, through the wetlands and the final spillway.

Pipework for the tailings and reclaim systems will systematically be removed once all water quality and pit flooding requirements are met. Similarly, the seepage collection ponds and recycle pumps would be retained until monitoring results indicate that drainage flows and seepage from the tailings area are of suitable quality for direct release to the environment. At that time, the seepage collection ponds could be decommissioned and the pumps removed. The groundwater monitoring wells and piezometers in the tailings embankment would be retained for use as long term monitoring devices. On-going monitoring of all reclamation measures will be carried out post closure, to confirm that the reclamation objectives are being achieved and sustained.

TABLE 1.1

MOUNT POLLEY MINING CORPORATION  
MOUNT POLLEY MINE

TAILINGS STORAGE FACILITY  
PERSONNEL AND RESPONSIBILITIES LIST

C:\Mount Polley\Tailings Management\OMS MANUAL\2006\Tables\Tab1-1 Personnel\_r1.xls\Sheet1

Printed on: Aug-28-06  
Revised on: August 28, 2006

Title	Name	Contact Information			Responsibilities
General Manager	Tim Fisch	Home:		Cell:	Responsible for overall activities of the TSF.
		Office:	250 790 2215	Pager:	
		E-mail:	tfisch@mountpolley.com		
Mill Operations Superintendent	Brock Taplin	Home:		Cell:	Daily management of the milling process and ensuring proper operation of the process system, equipment, and related components. Directs the operating crew in carrying out routine activities.
		Office:	250 790 2215	Pager:	
		E-mail:	tfisch@mountpolley.com		
Mine Operations Manager	Art Frye	Home:		Cell:	Daily management of any TSF construction activities.
		Office:	250 790 2215	Pager:	
		E-mail:	jgraham@mountpolley.com		
Environmental Superintendent	Ron Martel	Home:		Cell:	Arranges for an Annual Inspection of the TSF. Plans for future design raises and submits required permit admendments. Responsible for ensuring that mining and milling activities comply with the requirements of the applicable regulations governing the milling and tailings facilities. Responsible for updating the OMS manual
		Office:	250 790 2215	Pager:	
		E-mail:	rmartel@mountpolley.com		
Tailings Storage Facility Design Engineer	Ken Brouwer	Home:		Cell:	Familiar with the technical aspects as well as maintenance and inspection requirements of the TSF.
		Office:	(604) 685-0543	Pager:	
		E-mail:	kbrouwer@knightpiesold.com		
Ministry of Energy and Mines	Chris Carr	Home:		Cell:	
		Office:	250 952 0485	Pager:	
		E-mail:	chris.carr@gems7.gov.bc.ca		

Rev 0: Issued for OM&S Manual

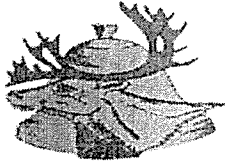

MINISTRY OF  
ENERGY AND MINES  
REC'D MAY 8 - 2006

**MOUNT POLLEY MINING CORPORATION  
MOUNT POLLEY MINE  
TAILINGS STORAGE FACILITY  
OPERATION, MAINTENANCE AND SURVEILLANCE  
MANUAL**

Rev. No.	Revision	Date	Approved
0	Issued in Final	December 22, 2004	
1	Issued in Final	February 06, 2006	RM
2	Issued in Final	March 31, 2006	RM

GRIT 4138

MOUNT POLLEY MINING CORPORATION  
MOUNT POLLEY MINE  
TAILINGS STORAGE FACILITY

OPERATION, MAINTENANCE AND SURVEILLANCE MANUAL  
(REF. NO. VA101-00001/9-1)

TABLE OF CONTENTS

	PAGE
SECTION 1.0 - INTRODUCTION .....	1
1.1 OVERVIEW .....	1
1.2 KEY PERSONNEL AND RESPONSIBILITIES .....	1
1.3 TRAINING REQUIREMENTS .....	1
1.4 DESIGN AND OPERATING CHANGES .....	1
1.5 CONTROL OF THIS MANUAL .....	2
1.6 REVISIONS TO THE MANUAL .....	2
1.7 REFERENCES .....	2
SECTION 2.0 - DESCRIPTION OF TAILINGS IMPOUNDMENT .....	3
2.1 GENERAL .....	3
2.2 DESIGN BASIS .....	3
2.3 PROJECT DESCRIPTION .....	3
2.3.1 Site Location .....	3
2.3.2 Project History .....	4
2.4 DESIGN FEATUES .....	4
2.5 DEPOSITION PLAN .....	4
2.6 CLOSURE PLAN .....	5
SECTION 3.0 - OPERATIONS MAINTENANCE AND SURVEILLANCE .....	6
3.1 GENERAL .....	6
3.2 TAILINGS BASIN .....	6
3.3 TAILINGS POND .....	7
3.3.1 Pond Level Operations .....	7
3.3.2 Surveillance .....	7
3.4 TAILINGS EMBANKMENT .....	8
3.4.1 Components .....	8
3.4.2 Surveillance and Maintenance .....	8
3.5 TAILINGS DISCHARGE PIPELINE .....	9
3.5.1 Components and Operation .....	9
3.5.2 Surveillance and Maintenance .....	10
3.6 RECLAIM PIPELINE .....	10
3.6.1 Components and Operation .....	10
3.6.2 Surveillance and Maintenance .....	11
3.7 SEDIMENT PONDS .....	11

3.7.1	Components and Operation .....	11
3.7.2	Surveillance and Maintenance .....	12
3.8	SEEPAGE COLLECTION PONDS.....	13
3.8.1	Components and Operation .....	13
3.8.2	Surveillance and Maintenance .....	13
3.9	INSTRUMENTATION .....	14
3.9.1	Components and Location.....	14
3.9.2	Surveillance and Maintenance .....	15
SECTION 4.0 - SAFETY INSPECTIONS AND REVIEWS .....		16
4.1	ANNUAL INSPECTIONS.....	16
4.2	DAM SAFETY REVIEW .....	16
SECTION 5.0 - EMERGENCY PREPAREDNESS AND RESPONSE PLANS .....		18
5.1	GENERAL.....	18
5.2	WARNING SIGNS .....	18
5.3	INCIDENT NOTIFICATION PROCEDURES.....	20
SECTION 6.0 - CERTIFICATION .....		21

## TABLES

Table 1.1 Rev 0	Personnel and Responsibilities List
Table 2.1 Rev 0	TSF Design Criteria
Table 3.1 Rev 0	Inspection and Surveillance Schedule
Table 3.2 Rev 0	Unusual Events and Occurrences requiring Non-Routine Walkovers
Table 3.3 Rev 0	Summary of Vibrating Wire Piezometers and Trigger Levels
Table 3.4 Rev 0	Summary of Slope Inclinometers and Trigger Levels
Table 3.5 Rev 0	Trigger Levels for Survey Monuments
Table 5.1 Rev 0	Emergency Warning Levels and Required Actions

## FIGURES

Figure 2.1 Rev 0	Project Location Plan
Figure 2.2 Rev 0	TSF Bathymetric Survey
Figure 3.1 Rev 0	Filling Schedule and Staged Construction – 18,500 tpd
Figure 3.2 Rev 0	Groundwater Monitoring Well Locations

## APPENDICES

APPENDIX A	References
APPENDIX B	Tailings Storage Facility – Inspection Log
APPENDIX C	Tailings Storage Facility – Instrumentation Data Sheets
APPENDIX D	TSF Stage 4 As-Built Drawings (in progress)
APPENDIX E	Selected photos of TSF components

**MOUNT POLLEY MINING CORPORATION  
MOUNT POLLEY MINE  
TAILINGS STORAGE FACILITY**

**OPERATION, MAINTENANCE AND SURVEILLANCE MANUAL**

**SECTION 1.0 - INTRODUCTION**

**1.1 OVERVIEW**

This Operations, Maintenance and Surveillance Manual applies to the Tailings Storage Facility and related pipelines and structures at the Mount Polley Mine. This Manual describes the roles and responsibilities of Mount Polley site personnel for the management of the TSF and associated facilities; operation, surveillance and maintenance requirements; inspection requirements; and emergency plans and procedures.

**1.2 KEY PERSONNEL AND RESPONSIBILITIES**

Table 1.1 identifies current key personnel (March 2006) and their responsibilities for management, operations, surveillance and inspections at the Mount Polley Mine Site and Tailings Storage Facility.

Government agencies involved in the operation, maintenance and surveillance of the Tailings Storage Facility include the Ministry of Energy and Mines (MEM); Ministry of Environment (MOE), Ministry of Forests (MOF); and Department of Fisheries and Oceans (DFO).

**1.3 TRAINING REQUIREMENTS**

Training programs are required for any personnel involved in the operation, inspection and surveillance of the Tailings Storage Facility. A refresher course is required once per year. The training programs must be conducted by the Environmental Superintendent, qualified Professional Engineer or a suitably qualified individual familiar with the design, operation, maintenance and inspection of all civil and mechanical works associated with the facility.

Each training session must be documented, and a record kept. The records will contain a detailed list of site activities for which the trainee was trained on, and be signed by the person who provided/supervised the training.

**1.4 DESIGN AND OPERATING CHANGES**

Changes to the design or operating plan for the Tailings Storage Facility and related pipelines and structures must be reviewed, approved and documented. Design changes may be submitted to the Engineer of Record for review. Operational changes will be reviewed and approved by the Mine Manager. In all cases, documentation of the change, including as-built records, are required.

## 1.5 CONTROL OF THIS MANUAL

This manual will be controlled by the Environmental Superintendent. Copies will be maintained at the following locations:

- One (1) copy for Mount Polley Mining Corporation (Vancouver office),
- One (1) copy for the Environmental Superintendent's office,
- One (1) copy for the Operating Crew (Mill Shifter's Office),
- One (1) copy for the Regional Water Manager (Williams Lake),
- Two (2) copies for the Director of the Provincial Emergency Program (P.E.P.),
- One (1) copy for the MOE, Dam Safety Engineer,
- One (1) copy for the MEM Geotechnical Manager,
- One (1) copy for the Design Engineer of Record.

Mount Polley Mining Corporation is responsible for maintaining a record of the location of each copy of the Manual and to ensure the copies in these locations are kept up to date.

## 1.6 REVISIONS TO THE MANUAL

Reviews of the Manual are conducted at least annually.

The operating procedures and personnel at the Mount Polley Mine may change during the operation of the mine. It is the responsibility of the Environmental Superintendent to ensure that the Operations, Maintenance and Surveillance Manual is updated to reflect these changes. Substantial revisions to the Manual shall be submitted to the Ministry of Energy and Mines.

A letter of transmittal that clearly identifies the distribution list must accompany each revision of this manual. An update may comprise the entire manual or be limited to specific pages or sections. A copy of each transmittal letter must be kept on record in the office of the Environmental Superintendent. Each revised page of the manual must be clearly marked as to the revision date prior to replacement. The replaced pages must be filed and kept on record in the office of the Environmental Superintendent.

## 1.7 REFERENCES

References relating to MPMC's Tailings Storage Facility and associated pipelines and facilities are included in Appendix A.



## SECTION 2.0 - DESCRIPTION OF TAILINGS IMPOUNDMENT

### 2.1 GENERAL

The following sections provide a brief summary of the design and management of the Tailings Storage Facility and associated facilities. Additional information is available in the cited references in Appendix A.

### 2.2 DESIGN BASIS

Mill tailings are discharged as slurry into the Tailings Storage Facility which has been designed to provide environmentally secure storage of the solid waste. As the solids settle out of the slurry, process fluids are collected and recycled back to the mill for re-use in the milling process. There is no surface discharge of any process solution from the Tailings Storage Facility. The basis of design must address the following:

- Permanent, secure and total confinement of all solid waste materials within a lined engineered impoundment,
- Secure and reliable transportation of the tailings from the mill to the Tailings Storage Facility,
- Collection and transport of runoff from waste rock storage areas to the Tailings Storage Facility,
- Temporary storage of supernatant water on the tailings beach, as required, with maximum recycling to the mill to produce a zero discharge condition for process water,
- Collection of all free draining liquids from the tailings deposit. Temporary storage is provided in lined external ponds. The water from the ponds is pumped into the supernatant pond and recycled to the mill to ensure that no discharges occur,
- Inclusion of monitoring facilities in the Tailings Storage Facility to confirm that the design objectives and operating requirements are being met,
- Staged development of the facility to enable modifications and upgrades to be implemented based on operating experiences and to distribute the capital expenditures over the life of the project.

The design basis and operating criteria for the Tailings Storage Facility and associated pipelines and structures are summarized in Table 2.1.

### 2.3 PROJECT DESCRIPTION

#### 2.3.1 Site Location

The location of the Mine and access roads are shown on Figure 2.1. The Mount Polley Mine is located in central British Columbia, approximately 60 km northeast of Williams Lake. The main access route is via Likely Road. The turn to the Mine is located approximately 1.5 km east of Morehead Lake. The Mine is located a further 11 km to the southeast, on the Bootjack Lake Forest Service Road.

The Tailings Storage Facility is accessible along the following two routes:

- Along the access road located on the south side of the Mill Site. This is the primary access to the TSF on the Mine site;
- Along the Gavin Lake Forest Service Road which can be access from Likely Road, located approximately 14 km south of Moorhead Lake. The TSF is located at approximately kilometre 16 along the road.

### 2.3.2 Project History

The Mount Polley mine commenced production in June 13, 1997. Ore is crushed and processed by selective flotation to produce a copper-gold concentrate. The mine was on care and maintenance status from October 2001 to February 2005. The mill throughput rate is approximately 18,500 tonnes per day (approx. 6.8 million tonnes per year). Mill tailings are discharged as slurry into the Tailings Storage Facility located on the south area of the Mine property. Additional historic information regarding the TSF and associated pipelines and facilities are available in the reports cited in Appendix A.

## 2.4 DESIGN FEATUES

Tailings slurry is conveyed from the Concentrator to the TSF via a tailings discharge pipeline. The tailings is deposited into the impoundment through moveable or fixed spigots on the embankment crest. A floating reclaim pump recycles process water from the supernatant pond in the TSF for use in the mill processing circuit. Sediment ponds and seepage collection ponds are designed to intercept runoff from the surface and seepage from the embankment respectively. Drains, instrumentation and monitoring wells are constructed in and around the TSF to assist in monitoring the performance of the facility. Additional details are available in the reports referenced in Appendix A. As-built drawings for the latest construction program are included in Appendix D.

## 2.5 DEPOSITION PLAN

The objectives of the long-term tailings deposition strategy is to:

- Maximize the storage capacity of the facility.
- Maintain the supernatant pond in the area of the reclaim barge so as to maximize the amount of clean process water available for reclaim.
- Establish free draining tailings beaches adjacent to the embankments during the winter season to facilitate future embankment raises and to enhance embankment stability.

The above strategy is implemented by sequentially rotating the tailings discharge point along the entire length of the Perimeter, Main and South embankments on the upstream face, which allows inactive areas of the tailings beach to partially dry and consolidate. Eventually, beaches will be formed around the entire upstream perimeter of the Facility and all supernatant water will be centralized around the reclaim barge.

Spigoted tailings settle in the tailings facility and form beaches with three distinct slopes. A sandy beach develops as the coarser tailings fraction settles more rapidly adjacent to the embankment. The average beach slope above water is about 0.5 percent. As the tailings flow into the supernatant pond it forms a submerged beach with a slope of 1 to 2 percent. Finer tailings particles are transported further out into the supernatant pond before settling at a slope of about 0.3 percent. The latest bathymetric survey of the tailings surface in the TSF is included in Figure 2.2.

## 2.6 CLOSURE PLAN

At closure of the Tailings Storage Facility, it is currently envisaged that the tailings surface will be decommissioned so as to develop a mixed forested/wetlands complex with a gradual transition towards a ponded area at the final spillway. This would require covering of the tailings embankments and the upland portions of the exposed tailings beach with a layer of soil stockpiled during operations. The topsoil would be revegetated with indigenous species of conifer and deciduous trees, willow and marsh land grasses. Ultimately, all water would be routed over the tailings surface, through the wetlands and the final spillway.

Pipework for the tailings and reclaim systems will systematically be removed once all water quality and pit flooding requirements are met. Similarly, the seepage collection ponds and recycle pumps would be retained until monitoring results indicate that drainage flows and seepage from the tailings area are of suitable quality for direct release to the environment. At that time, the seepage collection ponds could be decommissioned and the pumps removed. The groundwater monitoring wells and piezometers in the tailings embankment would be retained for use as long term monitoring devices. On-going monitoring of all reclamation measures will be carried out post closure, to confirm that the reclamation objectives are being achieved and sustained.

## SECTION 3.0 - OPERATIONS MAINTENANCE AND SURVEILLANCE

### 3.1 GENERAL

The Tailings Storage Facility is comprised of several components and associated facilities. These components and facilities must be inspected and maintained regularly to ensure that any changes to the TSF conditions, performance, or a potentially hazardous condition can be identified and promptly addressed. Selected photographs of the TSF and associated components are included in Appendix E. An inspection and surveillance schedule is provided on Table 3.1.

The Mill Superintendent is responsible for ensuring that surveillance is carried out regularly. The Mill Superintendent is responsible for daily management of the TSF and directs an operating crew to carry out routine activities. A list of site personnel and associated responsibilities are provided on Table 1.1.

The Environmental Superintendent will conduct a Dam Surveillance walkover at least once per quarter. All Dam Surveillance reports should be reviewed by the Mill Superintendent and filed at the Mount Polley Mine Site.

Additional (non-routine), documented walkovers of the TSF and associated facilities will be required following extreme or unusual events. The Mill Superintendent must be made aware of any unusual events or observations, and must contact the Design Engineer as required. Typical examples of unusual events and observations to be made during such walkovers are outlined in Table 3.2.

An inspection log is provided in Appendix B to help guide the observation and surveillance process. The inspection log covers major items related the TSF and associated facilities. Additional details are provided in the following sections.

### 3.2 TAILINGS BASIN

The projected rate at which the tailings basin will fill, combined with storage provisions for make-up and storm water, determine the rate of rise for the embankment. The anticipated filling schedule and staged construction sequence is shown on Figure 3.1.

Close monitoring of the pond elevation, depth, area and volume is important for the following reasons:

- To ensure that there is a sufficient volume of water available as make-up water while the pond is frozen and precipitation is at a minimum.
- To enable monitoring of the supernatant pond depth/area/volume so that tailings characteristics such as dry density can be determined.
- To monitor water recoveries.
- To enable the correlation of the pond level with other data, such as the piezometer pressures and drain flow quantities.

Adjustments to the basin filling curve may be required due to variation between actual and projected mill throughput rates, tailings deposition characteristics, water inputs and outputs and in-situ tailings density. Adjustments to these variables will change the rate of rise for the tailings and embankments.

The TSF was previously operated under a water deficient condition, which means more process water was needed than available in the supernatant pond. This condition changed once the mill starts up again in February 2005 and the mine will be operating under surplus conditions, which means there is more water in the system than is required. Therefore, a combination of careful water management and tailings deposition is required to maximize the storage potential in the embankment without compromising the freeboard or embankment stability.

### 3.3 TAILINGS POND

#### 3.3.1 Pond Level Operations

The TSF is required to have sufficient live storage capacity for containment of 679,000 cubic meters of runoff from the entire contributing catchment area during a 24-hour PMP event. This volume of stormwater would result in an incremental rise in the tailings pond level of approximately 0.39 meters. The TSF design also incorporates an allowance of 1 metre of freeboard for wave run-up. Therefore, the normal and maximum operating pond levels are as follows:

- Normal Operating Level – Water level at least 1.39 meters below the embankment crest;
- Maximum Operating Level – Water level is 1 meter below the embankment crest, which also means the loss of storage capacity for a 24-hour PMP event.

Tailings deposition will cease if the pond level reaches maximum operating level and the removal of water from the pond will commence using the reclaim barge. The area downstream of the dam will also be evacuated and access restricted as per the Emergency Preparedness Plan.

There are no restrictions, with respect to dam safety on the rate of filling of the supernatant pond up to the normal operating pond level or rate of emergency draw down within the pond.

#### 3.3.2 Surveillance

The pond level must be at least 1.39 meters below the crest elevation under normal operating conditions. Emergency procedures, discussed in Section 5.0, must be followed if the pond reaches the maximum operating level. Regular inspections of the pond level must be carried out according to the schedule outlined in Table 3.1. An inspection log is provided in Appendix B.

Additional pond level inspections are required after an unusual event. Table 3.2 outlines the additional observations that will need to be documented.

### 3.4 TAILINGS EMBANKMENT

#### 3.4.1 Components

The tailings embankment consists of the Main, Perimeter and South Embankments. The embankments are constructed using zoned earthfill and rockfill and have been raised in stages by a combination of centreline and modified centreline approaches. Details of the design and construction are reported in various Knight Piésold reports and are referenced in Appendix A.

An upstream toe drain on the Main embankment allows for the controlled removal of process water from the upstream face of the embankment. Foundation and chimney drains are also included in the embankments to prevent build-up of excess pore pressures beneath the embankment and to transfer groundwater and/or seepage to the seepage collection ponds located at the downstream toe of the Main and Perimeter Embankments.

Monitoring sumps are located at the downstream toe of the Main and Perimeter Embankments. They are used to facilitate monitoring of flow rates and water clarity from the embankment drains and diversion channels.

#### 3.4.2 Surveillance and Maintenance

Regular surveillance of the embankments and associated structures should follow the schedule outlined in Table 3.1. An inspection log is provided in Appendix B. Typical observations to be made during surveillance include:

- Evidence indicating dam structure deformation (e.g. slope bulging, tension cracks on the crest or crest settlement);
- Evidence indicating seepage, runoff or erosion;
- Clarity and quantity (visual estimate) of seepage water entering the seepage collection sumps;
- Possible evidence indicating piping downstream of the embankments;
- Other unusual conditions in the TSF area.

The embankment and associated structures do not require regular maintenance; however, specific maintenance items may be identified as a result of regular observations and surveillance of the embankment.

Table 3.2 outlines additional observations that will need to be documented after any unusual event.

### 3.5 TAILINGS DISCHARGE PIPELINE

#### 3.5.1 Components and Operation

Tailings slurry is conveyed from the Concentrator through approximately 7000 metres of HDPE pipe to the TSF where it is discharged through a series of spigots along the embankment crest. The pipeline includes the following components:

- A 556 mm diameter DR 17 HDPE pipe from the Concentrator to the T2 Dropbox;
- A 610 mm diameter DR 15.5 HDPE pipe from the T2 Dropbox to the TSF;
- Two short sections of 762 mm diameter DR 15.5 HDPE pipe are included at the start of the two pipeline sections at the Concentrator and the T2 Dropbox to ensure that flows are not restricted at the inlet;
- The T2 Dropbox;
- Moveable discharge section;
- A Dump Valve at the start of the Perimeter Embankment.

The tailings pipeline is located on the shoulder of the access road from the mine. Tailings slurry is gravity fed to the TSF through the tailings pipeline. The tailings pipeline has a variable downhill slope that ranges from 0.5% to 8.0% which ensures drainage.

The T2 Dropbox is located approximately mid-way along the pipeline and allows for the addition of runoff from the Southeast Sediment Pond into the tailings stream. It also serves as an overflow for the reclaim booster sump.

A 200 metre long discharge section connected with six spigots (150 mm diameter) is used to control deposition of tailings over the tailings beach in the TSF. The discharge section can be installed in different locations along the pipeline to facilitate even distribution of tailings onto the beaches. A dump valve is located at the start of the Perimeter Embankment to allow discharge of tailings during relocation of the discharge section.

The tailings discharge pipeline does not require any external adjustments during normal operations. The discharge pipeline will drain by gravity to the TSF in the event of a mill shutdown or power failure. However, the following points must be remembered during operation of the pipeline:

- Never leave all valves closed along the tailings discharge pipeline as they may be permanently blocked from sanding or suffer damages from excessively high pressures;
- Ensure that there is an open pathway for tailings to exit before the pipeline is filled or the spigots are relocated;
- Flush the pipeline prior to shutdown or relocation.

The T2 Dropbox does not require any external adjustments during normal operations. During a mill shutdown or during freezing conditions the valve between the Southeast Sediment Pond and the T2 Dropbox must be open in order to prevent water from filling up the Reclaim Booster Sump when the pumps are not operating.

### 3.5.2 Surveillance and Maintenance

The tailings discharge pipeline will be inspected and maintained regularly to ensure that the system operates properly. Table 3.1 provides a schedule for regular surveillance of the pipeline. An inspection log is provided in Appendix B. Typical observations to be made during surveillance include:

- Locations of excessive wear of the pipeline;
- Evidence indicating leakage from the pipeline;
- The water level in the T2 Dropbox to ensure that there is no blockage in the discharge pipeline downstream;
- Ensure that the valve between the Dropbox and Southeast Sediment Pond is open during a mill shutdown or freezing conditions when the booster pump is shut off.

Additional inspections are required after an unusual event. Table 3.2 outlines additional observations that will need to be documented. Repairs to the discharge pipeline, dropbox and/or discharge sections may be required after any unusual event.

## 3.6 RECLAIM PIPELINE

### 3.6.1 Components and Operation

Reclaim water is pumped from the Tailings Storage Facility for re-use at the Mill site. The reclaim pipeline includes the following components:

- Floating Reclaim Pump Barge;
- A 610 mm diameter steel pipe connecting the barge to the reclaim line;
- Booster Pump Station beside the T2 Dropbox;
- A 610 mm diameter HDPE pipe from the steel pipe to the Booster Pump Station;
- A 610 mm diameter HDPE pipe from the Booster Pump Station and the Mill site;

The floating reclaim pump barge is located in the TSF in an excavated channel. The barge is accessible from land along an access walkway. The floating reclaim pump barge was designed by others. Refer to the manufacturer's manual for details related to operations, inspections and maintenance.

The reclaim pipeline is located beside the tailings pipeline on the shoulder of the access road. The pressure rating of the HDPE pipeline decreases as it approaches the Booster Pump Station and Mill site.



The Booster Pump Station is located mid-way along the reclaim pipeline, beside the T2 Dropbox. A valve located on the pipeline leading in from the Southeast Sediment Pond may be used to divert water into the reclaim pipeline. Water from the Southeast Sediment Pond can be diverted into the reclaim pipeline only if it is clear. Two overflow pipes connect the sump beneath the pump station to the T2 Dropbox to ensure water will not overflow in the pump station sump.

The reclaim pipeline does not require any external adjustments during normal operations. However, during maintenance periods, barge relocation or during a prolonged shutdown under extreme cold conditions the reclaim system should be drained via a drain valve located on the barge.

The Pump Barge and Booster Pump Station may be operated from the Mill control room. Both pumps may also be operated locally from the barge or pump station to provide water as required at the Mill site.

### 3.6.2 Surveillance and Maintenance

The reclaim pipeline, pump barge and booster pump station shall be inspected according to the schedule outlined in Table 3.1 and an inspection log completed as provided in Appendix B. Typical areas to inspect during surveillance of the reclaim pipeline include:

- Locations of excessive wear of the pipeline;
- Evidence indicating leakage from the pipeline;
- Monitor Pond and Barge elevations to ensure that a gradient is maintained in the steel pipe. The barge ramp may need to be relocated higher;
- The de-icing system for the pump barge should be checked to ensure that it is working prior to freezing conditions.
- Monitor water from the Southeast Sediment Pond to ensure that it's clear before diverting it to the reclaim line;

Additional inspections are required after any unusual event. Table 3.2 outlines additional observations that will need to be documented. Repairs to the reclaim pipeline, barge and/or pump station may be required after any unusual event.

## 3.7 SEDIMENT PONDS

### 3.7.1 Components and Operation

A series of diversion ditches divert runoff to two collection ponds where the water is then directed to the TSF or pumped back to the Mill site. The two ponds are the Mill Site Sump and the Southeast Sediment Pond.

The Mill Site Sump is located south of the Concentrator Building. Runoff water from the Mill Site area is collected along diversion ditches and directed to the sump. The water

collected in the sump is either pumped back to the mill or allowed to flow by gravity to an inlet point (T1) on the tailings pipeline. The normal operating level is the invert of the bottom inlet at the manhole (El. 1102.7 metres). The water level is kept at this low level so that storage capacity for the design storm event is available in the sump. Discharge from the manhole is conveyed to the reclaim line in an 8 inch (200 mm) HDPE pipeline. The pipeline is buried through the Millsite area and runs in the pipe containment channel, where it is connected to the 22 inch DR17 HDPE tailings line via a prefabricated Tee in a section of the pipeline that flows by gravity (non-pressurized flow). Currently, water is pumped into the reclaim line immediately adjacent to the Millsite Sump. The water level is maintained at the bottom inlet on the manhole at all times.

The Southeast Sediment Pond is located south of the waste rock storage area. Runoff water from the waste rock dump is collected along diversion ditches at the toe and directed to the pond. Water is decanted through a manhole which has four valved inlet pipes which can be used to control the water level in the sediment pond. The normal operating level is the invert of the second inlet at the manhole (El. 1054.5 metres). The water shall not be permitted to rise above this so that storage capacity for the design storm event is available in the pond. A 10 inch (250 mm) DR21 HDPE discharge pipeline runs from the manhole to the reclaim booster sump. By using manually operated valves at the sump, the water can be directed to the sump, if sufficiently clear, or into the T2 Dropbox.

### 3.7.2 Surveillance and Maintenance

The Mill Site Sump and Southeast Sediment Pond shall be inspected according to the schedule outlined in Table 3.1 and an inspection log completed as provided in Appendix B. Typical observations to be made during surveillance include:

- Water levels in the Mill Site Sump and Southeast Sediment Pond;
- Evidence indicating leakage from the pipelines;
- Erosion in the collection ditches;
- Evidence indicating slope deformation or erosion (i.e. tension cracks at the crest, erosion channels, bulging at the toe);
- Evidence indicating seepage out of the ponds.

The sediment ponds do not require regular maintenance; however, specific maintenance items may be identified during regular surveillance of the ponds.

Table 3.2 outlines additional observations that will need to be documented after any unusual event.

## 3.8 SEEPAGE COLLECTION PONDS

### 3.8.1 Components and Operation

The Main and Perimeter Seepage Collection Ponds are located at the downstream toe of the Main and Perimeter Embankments respectively. The ponds collect drainage water from the toe and foundation embankment drains as well as from local runoff.

A corrugated steel pipe connects each pond to a seepage recycle sump where recycle pumps are located. The pumps will recycle the seepage water back into the TSF through 6" diameter HDPE pipes that extend over the embankment crest. Level sensors in the seepage recycle sump controls the pumping frequency.

The seepage collection ponds and recycle pumps generally operate without requiring any external adjustments. However, the following special circumstances require adjustments to the operating procedures:

- During spring freshet, the pumps may not be able to keep up with the high inflows. All diversion ditches that feed the ponds may need to be directed away. Also, if water quality and permits allow, discharge of water may be possible.
- Under freezing conditions, the pumps are operated on a timed pumping cycle based on site conditions to prevent the pipes from freezing. The pumps will turn on and off based on the cycle time rather than water level. Once the temperatures return to normal the pumps can operate under normal conditions.

### 3.8.2 Surveillance and Maintenance

The seepage collection ponds and recycle pumps shall be inspected according to the schedule outlined in Table 3.1 and an inspection log completed as provided in Appendix B. Typical observations to be made during surveillance is as follows:

- Water levels in both collection ponds;
- Pumpback flow rates from both pumps;
- Evidence indicating seepage from the collection ponds;
- Evidence indicating erosion or instability on the slopes of the ponds
- The overflow culverts and pipelines between the monitoring sumps and recycle sumps are free of any obstructions;
- Ensure that the discharge end of the seepage recycle pipeline isn't submerged in tailings.

Additional observations will also be required under special circumstances as follows:

- Monitor the pumping from the ponds during freezing conditions to ensure that the pumping cycle is adequate at keeping the pipes from freezing and in keeping the pond level constant;

- Monitor the water quality in the ponds during spring freshet to ensure that the seepage water from the TSF is at acceptable levels if water permits allow for discharge.

Table 3.2 lists additional events and circumstances that will require increased observations and documentation.

### 3.9 INSTRUMENTATION

#### 3.9.1 Components and Location

The tailings embankment and associated facilities were installed with various instrumentation to assist in monitoring the facility. The various components are as follows:

- Vibrating Wire Piezometers;
- Slope Inclinometers;
- Survey and Surface Movement Monuments;
- Groundwater Monitoring Wells.

The locations of the piezometers, slope inclinometers, and survey monuments are shown on the drawings located in Appendix D.

The piezometers measure the pore pressures in the foundation soils, embankment foundation drains and embankment fill. They are connected to instrumentation readout panels located on the crest of the embankments and read using a piezometer readout box. A summary of the existing vibrating wire piezometers is presented on Table 3.3 with trigger levels, which if exceeded, will require investigation and possible contingency or remedial actions. Data may be entered on the piezometer data sheet included in Appendix C. A summary of the piezometer data will be sent to Knight Piésold according to the schedule outlined on Table 3.1

Two slope inclinometers were installed at the toe of the Main Embankment in order to measure potential deformation of the embankment materials. Operational procedures for operation of the inclinometer probe and data reduction are provided in the manufacturer's instruction book. Readings are carried out manually and displacements are calculated using software from RST and spreadsheets set up by MPMC. The spreadsheets are updated on site and summaries will be sent to Knight Piésold regularly. A summary of the existing slope inclinometers is presented on Table 3.4 with trigger levels, which if exceeded, will require investigation and possible contingency or remedial actions.

Survey and surface movement monuments (to be installed) will be used to measure the vertical and lateral movement of the earthfill dams. Data is entered on the survey data sheet included in Appendix C. Trigger levels and the required appropriate actions are

summarized on Table 3.5. A summary of the results will be sent to Knight Piésold according to the schedule outlined on Table 3.1.

Groundwater monitoring wells are located around the perimeter of the TSF. MPMC regularly measures the water levels and water quality from each well and submits the reports to the appropriate agencies. The location of the groundwater monitoring wells is shown on Figure 3.2.

### 3.9.2 Surveillance and Maintenance

All instrumentation components must be read regularly. The monitoring frequency for each is outlined on the schedule in Table 3.1. Data may be entered on the appropriate sheets included in Appendix C.

Data must be collected, plotted and reported according to the schedule outlined in Table 3.1. The design engineer must be notified of any anomalous trends. Additional readings and inspections as outlined in Table 3.2 will also be required after any unusual event or observation.

Generally, the instruments do not require regular maintenance but may require occasional maintenance as follows:

- The piezometer wires may need to be cut and re-attached if the readout box is unable to acquire any data;
- Piezometer wires that are exposed may become corroded and may need to be trimmed until a fresh surface is exposed to allow readings to be taken;
- Cover survey points with 20 litre buckets to keep snow off in the winter months;
- Protect surface movement monuments with used tires. These monuments need to be re-established and protected again after construction of a new embankment lift.

## SECTION 4.0 - SAFETY INSPECTIONS AND REVIEWS

### 4.1 ANNUAL INSPECTIONS

Annual Inspections of the tailings impoundment and associated facilities are required to evaluate the current and past performance of the facility and to observe potential deficiencies in its condition, performance and/or operation. The Environmental Superintendent is responsible for arranging the inspections. This level of dam safety evaluation should be based on detailed observations made by the Design Engineer on site and the relevant information on the TSF operations collected by site personnel. Additional reviews may be required also as a follow up to the report of an unusual event or observation.

The Environmental Superintendent should accompany the Design Engineer during the annual inspection. The Design Engineer will evaluate the safety of the TSF and incorporate a routine review of the following:

- The consequences classification of the dam;
- The operations and maintenance manual;
- The availability of all documents pertaining to dam safety on site;
- The site surveillance practice;
- Changes in relevant regulatory requirements since the last inspection.

The Design Engineer will issue an annual inspection report after completing the review. The report will include the following:

- Conclusions on the status of the TSF;
- Statements indicating completion of recommendations from previous inspections and reviews;
- New recommendations if necessary.

The Mill Superintendent and the Ministry of Energy and Mines should review each annual inspection report. Copies of the reports should be made available on site and are available in the office of the Design Engineer. The Mill Superintendent should prepare and execute an appropriate action plan to ensure that all recommendations made in the annual inspection report are followed. This action plan should be documented.

### 4.2 DAM SAFETY REVIEW

The principle objective of a Dam Safety review (DSR) is to ascertain that a dam has an adequate margin of safety, based on the current engineering practice and updated design input data. A DSR may also be carried out to address a specific problem.

A qualified engineer will be responsible for conducting each DSR at the Tailings Storage Facility. The engineer conducting the DSR must be qualified to conduct safety evaluations and be familiar with the designs and other site-specific conditions and requirements pertaining to operations of

the impoundment and associated facilities; but ideally should not have been involved in the design, construction or operation of the TSF.

Routine DSR's at the TSF will be carried out every 5 years but this scheduling requirement should be confirmed or revised at the time of each annual inspection. The next DSR for the TSF is scheduled for 2006.

A detailed scope of work for each DSR will be defined by the engineer prior to conducting the review, and be consistent with current engineering practice at the time it is conducted. Each DSR will evaluate the safety of the TSF and incorporate a detailed review of the following:

- The consequences classification of the dam;
- The adequacy of past annual inspection practice, the annual inspection recommendations, and their implementation;
- The Operation and Maintenance Manual;
- Timing for the next regular DSR.

Each DSR report should include conclusions and, if necessary, recommendations pertaining to the safety of the TSF. Copies of the DSR will be sent to the Environmental Superintendent and the Ministry of Energy and Mines for review. Similar to the annual inspection report, an action plan should be prepared by the Mill Superintendent to address the DSR recommendations. A copy of each report will be sent to the Ministry of Energy and Mines and will also be available at the site and at the office of the Design Engineer.

## SECTION 5.0 - EMERGENCY PREPAREDNESS AND RESPONSE PLANS

### 5.1 GENERAL

This Emergency Preparedness and Response Plan will enable MPMC to identify emergency and hazardous conditions threatening the TSF, expedite effective response actions to prevent failure, and reduce loss of life and property damage should failure occur.

In the event that MPMC is unable to comply with any of the terms and conditions of the permit, due to any cause, MPMC will:

- 1) Immediately notify the Ministry of Energy and Mines of the failure to comply.
- 2) Immediately take action to stop, contain, and clean up unauthorized discharges or otherwise stop the non-compliance, correct the problem, and if applicable, repeat sampling and analysis of any non-compliance immediately.
- 3) Submit a detailed written report to the Ministry of Energy and Mines within thirty (30) days (five days for upsets and bypasses), unless requested earlier by the Ministry of Energy and Mines. The report will contain a description of the non-compliance, including exact dates and times, if the non-compliance has not been corrected, the anticipated time it is expected to continue; and the steps taken or planned to reduce, eliminate, and prevent reoccurrence of the non-compliance.

Copies of the Emergency Preparedness and Response Plan will be kept in the following locations:

- One (1) copy for Mount Polley Mining Corporation (Vancouver office),
- One (1) copy for the Environmental Superintendent's office.
- One (1) copy for the Office (near office radio and telephone).
- One (1) copy for the Operating Crew (Mill Shifter's Office),
- Three (3) copies for the Comptroller of Water Rights,
- One (1) copy for the Regional Water Manager (Williams Lake),
- Two (2) copies for the Director of the Provincial Emergency Program (P.E.P.),
- One (1) copy for the MOE, Dam Safety Engineer,
- One (1) copy for the MEM Geotechnical Manager,
- One (1) copy for the Design Engineer of Record.

### 5.2 WARNING SIGNS

Three levels of emergency conditions (or warning signs) can be identified with respect to the site operations. These are defined as follows:

#### Level 1

Unusual conditions that do not yet represent a potential emergency, but do require prompt investigation and resolution.



### Level 2

Conditions that represent a potential emergency, if sustained or allowed to progress, but no emergency situation is imminent.

### Level 3

An emergency defined by either failure of a significant component of the TSF and/or associated facility or a significant failure of the performance of a component of the TSF. Such failure may have already occurred, or be imminent.

Typical situations that would be classified under the three levels of emergency conditions (Level 1, 2 or 3) and the actions to be taken, are outlined in Table 5.1 and described below:

#### **Level 1 Situation**

The action in the event of a Level 1 Emergency Condition will typically involve an investigation, intensified monitoring, inspecting and/or testing, and defining and implementing possible corrective measures.

Construction equipment will be available at the Mine and include, but not be limited to, an excavator, a grader, and a bulldozer. Material will be available both at the TSF and at the Mine for use in repairing or remediation of any damaged areas.

#### **Level 2 Situation**

The first action in the event of a Level 2 Emergency Condition is to discuss and define an action plan, at the site, under the direction of the Mill Superintendent. After such a plan is prepared, it must be presented to the Mine Manager for approval. Construction equipment should be made available, if required, at short notice.

#### **Level 3 Situation**

The first actions in the event of any Level 3 Emergency Condition are:

- Check that all persons who could possibly be affected are safe; and
- Initiate the appropriate chain of communications.

The person who initiated the communication should then stand-by at a safe location near the problem area and await further instructions or decisions. All those involved in emergency response, after first having communicated with the appropriate parties, should consider two types of actions as first steps in the emergency response, with respect to the protection of human life and health, environment and property:

- What can be done to prevent the situation from worsening?
- What can be done to reduce the consequences of the impending or actual failure?

Any such action must be presented to the Mine Manager who will decide on its implementation in consultation with the Ministry of Energy and Mines.

### 5.3 INCIDENT NOTIFICATION PROCEDURES

The following incident notification procedures are to be followed for all emergency conditions.

#### **Level 1 and Level 2**

The notification procedures are as follows:

- The person first noticing a Level 1 or Level 2 Emergency Condition shall notify the Mill Superintendent and initiate corrective actions and intensified monitoring.
- The Mill Superintendent shall notify the Design Engineer as appropriate.

#### **Level 3**

The notification procedure for a Level 3 Emergency Condition is as follows:

- The person noticing a Level 3 Emergency Condition shall notify the Mine Manager and Mill Superintendent and initiate corrective actions and/or intensified monitoring, as appropriate.
- The Mine Manager shall notify MPMC Public relations, MPMC Project director, and the Design Engineer.

In the event of an emergency situation that will result in an actual or potentially imminent dam failure, or release of untreated water, the Mine Manager shall also notify the Ministry of Energy and Mines.

Names and telephone numbers for the key contacts are given in Table 1.1

SECTION 6.0 - CERTIFICATION

This report was prepared and approved by the undersigned.

Prepared by:



Apr 26-2006

Ron Martel  
Environmental Superintendent

Approved by:

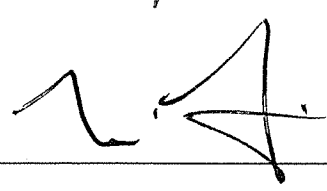

Tim Fisch  
Mine Manager

This report was prepared by Knight Piésold Ltd. for the account of Mount Polley Mining Corporation. The material in it reflects Knight Piésold's best judgement in light of the information available to it at the time of preparation. Any use which a third party makes of this report, or any reliance on or decisions to be made based on it, is the responsibility of such third parties. Knight Piésold Ltd. accepts no responsibility for damages, if any, suffered by any third party as a result of decisions made or actions, based on this report. This numbered report is a controlled document. Any reproductions of this report are uncontrolled and may not be the most recent revision.

TABLE 1.1

MOUNT POLLEY MINING CORPORATION  
MOUNT POLLEY MINE

TAILINGS STORAGE FACILITY  
PERSONNEL AND RESPONSIBILITIES LIST

C:\Mount Polley\Tailings Management\OMS MANUAL\2006\Tables\Tab1-1 Personnel\_r0.xls\Sheet1

Printed on: Apr-26-06  
Revised on: Dec 20, 2004

Title	Name	Contact Information			Responsibilities
Mine Manager	Tim Fisch	Home:	Cell:		Responsible for overall activities of the TSF.
		Office: 250 790 2215	Pager:		
		E-mail: <a href="mailto:tfisch@mountpolley.com">tfisch@mountpolley.com</a>			
Mill Operations Superintendent	Brock Taplin	Home:	Cell:		Daily management of the milling process and ensuring proper operation of the process system, equipment, and related components. Directs the operating crew in carrying out routine activities.
		Office: 250 790 2215	Pager:		
		E-mail: <a href="mailto:tfisch@mountpolley.com">tfisch@mountpolley.com</a>			
Mine Superintendent	John Graham	Home:	Cell:		Daily management of any TSF construction activities.
		Office: 250 790 2215	Pager:		
		E-mail: <a href="mailto:jgraham@mountpolley.com">jgraham@mountpolley.com</a>			
Environmental Superintendent	Ron Martel	Home:	Cell:		Arranges for an Annual Inspection of the TSF. Plans for future design raises and submits required permit amendments. Responsible for ensuring that mining and milling activities comply with the requirements of the applicable regulations governing the milling and tailings facilities. Responsible for updating the OMS manual
		Office: 250 790 2215	Pager:		
		E-mail: <a href="mailto:rmartel@mountpolley.com">rmartel@mountpolley.com</a>			
Tailings Storage Facility Design Engineer	Ken Brouwer	Home:	Cell:		Familiar with the technical aspects as well as maintenance and inspection requirements of the TSF.
		Office: (604) 685-0543	Pager:		
		E-mail: <a href="mailto:kbrouwer@knightpiesold.com">kbrouwer@knightpiesold.com</a>			
Ministry of Energy and Mines	Chris Carr	Home:	Cell:		
		Office: 250 952 0485	Pager:		
		E-mail: <a href="mailto:chris.carr@gems7.gov.bc.ca">chris.carr@gems7.gov.bc.ca</a>			

Rev 0: Issued for OM&S Manual

TABLE 3.3

**MOUNT POLLEY MINING CORPORATION  
MOUNT POLLEY MINE  
TAILINGS STORAGE FACILITY**

**SUMMARY OF VIBRATING WIRE PIEZOMETERS AND TRIGGER LEVELS**

Printed:06-Mar-2006

\\Server1\data\Enviro\Mount Polley\Tailings Management\OMS MANUAL\2006[Table 3 3\_r0.xls]Table 3.3\_R0

Revised:20-Dec-2004

0.3 Identification Number	Serial Number	Tip El. (m)	Zone Monitored	Trigger Level		
				Frequency (Hz)	Pressure (m H2O)	Elevation (m)
A0-PE1-01	69689	938.5	Cycloned Tailings			
A0-PE2-01	43675	928.0	Tailings			
A0-PE2-02	43657	927.9	Tailings			
A1-PE1-01	64100	913.0	Foundation Drain	3000	2.0	915.0
A1-PE1-02	64098	912.1	Foundation Drain	3040	2.0	914.1
A1-PE1-03	64105	917.2	Chimney Drain	3015	2.0	919.2
A1-PE1-04	43649	936.3	Upstream Toe Drain			
A2-PE1-01	67191	913.3	Zone T Fill			
A2-PE1-02	69690	938.5	Glacial Till Fill			
A2-PE1-03	69697	909.3	Foundation, depth 1.5 m	<b>Not Functioning</b>		
A2-PE2-01	64104	903.7	Foundation, depth approx. 9.0 m	2875	15.0	918.7
A2-PE2-02	64103	909.8	Foundation, depth approx. 2.9 m	3000	8.9	918.7
A2-PE2-03	64101	919.4	Glacial Till Fill			
A2-PE2-04	64099	926.1	Glacial Till Fill	<b>Not Functioning</b>		
A2-PE2-05	64102	921.9	Glacial Till Fill			
A2-PE2-06	43650	898.9	Foundation, depth approx.	2810	20.5	919.4
A2-PE2-07	43654	902.8	Foundation, depth approx.	2840	16.6	919.4
A2-PE2-08	67195	907.6	Foundation, depth approx.	2995	11.8	919.4
B0-PE1-01	69692	939.1	Cycloned Tailings			
B0-PE2-01	43674	927.3	Tailings			
B0-PE2-02	43676	927.2	Tailings			
B1-PE1-01	64107	917.3	Foundation Drain	3090	2.0	919.3
B1-PE1-02	64106	916.0	Foundation Drain	3080	2.0	918.0
B1-PE1-03	64118	918.7	Chimney Drain	3115	2.0	920.7
B2-PE1-01	67194	916.3	Zone T			
B2-PE1-02	69693	939.4	Glacial Till Fill			
B2-PE1-03	69696	914.1	Foundation, depth 1.5 m	2964	7.5	921.6
B2-PE2-01	64110	902.0	Foundation, depth approx. 15.0 m	2840	21.0	923.0
B2-PE2-02	64116	909.5	Foundation, depth approx. 7.9 m	2865	13.9	923.4
B2-PE2-03	64109	921.0	Glacial Till Fill			
B2-PE2-04	64108	921.0	Glacial Till Fill			
B2-PE2-05	64113	921.7	Glacial Till Fill			
B2-PE2-06	43652	914.6	Foundation, depth approx. 2.3 m	2980	8.5	923.0
C0-PE1-01	69694	938.3	Cycloned Tailings			
C0-PE2-01	43673	927.8	Tailings	<b>Not Functioning</b>		
C0-PE2-02	43658	927.5	Tailings	<b>Not Functioning</b>		
C1-PE1-01	64111	914.7	Foundation Drain	3070	2.0	916.7
C1-PE1-02	64115	916.6	Chimney Drain	3070	2.0	918.6
C1-PE1-04	43653	914.3	Foundation Drain	2960	2.0	916.3
C2-PE1-01	67196	915.0	Zone T			
C2-PE1-02	69695	938.5	Glacial Till Fill			

TABLE 3.3

MOUNT POLLEY MINING CORPORATION  
MOUNT POLLEY MINE  
TAILINGS STORAGE FACILITY

SUMMARY OF VIBRATING WIRE PIEZOMETERS AND TRIGGER LEVELS

Printed:06-Mar-2006

\\Server1\data\Enviro\Mount Polley\Tailings Management\OMS MANUAL\2006\[Table 3.3\_r0.xls]Table 3.3\_R0

Revised:20-Dec-2004

0.3 Identification Number	Serial Number	Tip El. (m)	Zone Monitored	Trigger Level		
				Frequency (Hz)	Pressure (m H2O)	Elevation (m)
C2-PE1-03	69698	912.6	Till Foundation, depth 1.5 m	2979	7.5	920.1
C2-PE2-01	64117	907.5	Foundation	<b>Not Functioning</b>		
C2-PE2-02	64119	910.5	Foundation, depth approx. 5.2 m	2955	11.2	921.7
C2-PE2-03	64112	921.0	Glacial Till Fill			
C2-PE2-05	64114	924.8	Glacial Till Fill	<b>Not Functioning</b>		
C2-PE2-06	43647	906.6	Foundation, depth approx. 9.1 m	2940	15.4	922.0
C2-PE2-07	43655	912.3	Foundation, depth approx. 3.7 m	3000	9.7	922.0
C2-PE2-08	43656	914.0	Foundation, depth approx. 2.0 m	3000	8.0	922.0
D1-PE1-02	66520	928.8	Outlet Drain			
D1-PE1-03	50679	934.0	Chimney Drain			
D2-PE1-01	67193	930.4	Zone T			
D2-PE2-01	64096	931.0	Glacial Till Fill			
D2-PE2-02	67192	927.3	Foundation			
E2-PE2-01	43651	914.2	Foundation, depth approx. 4.6 m	2930	10.6	924.8
E2-PE2-02	43648	909.7	Foundation, depth approx. 9.1 m	2980	15.1	924.8
F2-PE2-01	53765		Foundation, depth 1.3 m			
G1-PE1-01	50678	934.0	Chimney Drain			
H1-PE1-01	50681	934.0	Chimney Drain			

Notes:

1. Trigger level is the level at which the monitoring frequency must be increased (daily) and when contingency or remedial plans must be developed.
2. The trigger level for foundation piezometers is approx. 6.0 metres above ground and is based on the level where the factor of safety is approaching 1.1.
3. The trigger level for drain piezometers is approx. 2.0 metres of head.
4. Fill piezometers have no set trigger level, but must be closely monitored for pressure increases.

Rev 0 - Issued for OMS Manual

TABLE 3.4

MOUNT POLLEY MINING CORPORATION  
MOUNT POLLEY MINE  
TAILINGS STORAGE FACILITY

SUMMARY OF SLOPE INCLINOMETERS AND TRIGGER LEVELS

Printed:06-Mar-2006

\\Server1\data\Enviro\Mount Polley\Tailings Management\OMS MANUAL\2006\[Table 3 4\_r0.xls]Table 3.4\_r0

Revised:20-Dec-2004

Inclinometer Identification Number	Ground El. (m)	Depth (m)	Zone Monitored	Horizontal Displacement Trigger Level
SI01-01	915.70	24.38	Foundation	25 mm
SI01-02	917.30	30.33	Foundation	25 mm

Notes:

1. Trigger level is the level at which the monitoring frequency must be increased (daily) and when contingency or remedial plans must be developed.

Rev 0 - Issued for OMS Manual

TABLE 3.5

MOUNT POLLEY MINING CORPORATION  
MOUNT POLLEY MINE  
TAILINGS STORAGE FACILITY

TRIGGER LEVELS FOR SURVEY MONUMENTS

Printed: 06-Mar-2006  
Revised: 20-Dec-2004

\\Server1\data\Enviro\Mount Polley\Tailings Management\OMS MANUAL\2006\Table 3.5\_r0.xls\Tab 3-5\_r0

DISPLACEMENT TYPE	DESCRIPTION	LEVEL	MAGNITUDE OF DISPLACEMENT (m)	ACTION
Settlement	Loss of fill elevation associated with small displacements in upstream or downstream direction.	1	DEI = -0.01 to -0.02	Continue survey and inspections.
		2	DEI = -0.02 to -0.05	See Contingency 1.
		3	DEI > -0.05	Inspect embankment for cracking, sloughing or slumping. If observed, complete actions for Contingency 2. If not, notify Design Engineer, increase survey frequency to monthly and complete daily inspections.
Crest Movement	Displacement in the upstream or downstream directions, associated with minor changes in embankment crest elevation.	1	Dxy = ±0.03	Slight deformations in the downstream direction may occur during initial basin filling. Continue inspections and surveys.
		2	Dxy = ±0.05	See Contingency 1.
		3	Dxy > 0.05	Inspect embankment for cracking, sloughing or slumping. If observed, complete actions for Contingency 2. If not, notify Design Engineer increase survey frequency to monthly and complete daily inspections.
<b>Contingency Actions</b>				
1	Inspect the embankment crest and slopes for cracking, sloughing or slumping. If any of these are noted see Contingency 2. Otherwise continue with survey and inspection. Forward results to the Design Engineer immediately.			
2	Cracks, sloughing or slumping found; determine size of affected area and photograph. Collect baseline measurements (e.g. length of crack, separation amount of movement, and rate of movement- if any). Closely inspect the embankment crest and slopes for other deformations, and the tailings beach for sinkholes or for unusual tailings or water movement or disturbance. Contact the Design Engineer with this information immediately. Inspect again, and determine if cracking or movement is continuing or accelerating. Arrange for additional survey monuments and increase frequency of inspection to twice daily. Survey daily until it is determined if displacements are continuing or accelerating. Arrange for an inspection by a suitably qualified Engineer.			



TABLE B-1  
MOUNT POLLEY MINING CORPORATION  
MOUNT POLLEY MINE

TAILINGS STORAGE FACILITY  
INSPECTION LOG

Printed on: Mar-06-06  
Revised on: Dec 20, 2004

\\Server1\data\Enviro\Mount Polley\Tailings Management\OMS MANUAL\2006\TabB-1 Inspection I

<b>INSPECTOR:</b>	
<b>DATE:</b>	
<b>WEATHER CONDITION:</b>	
<b>General Notes to Inspectors</b>	
<ul style="list-style-type: none"> <li>- Take photographs of the tailings storage facility, pipeworks and associated structures <b>regularly</b> (and of all unusual observations and events) for use as a photographic record of the storage facility.</li> <li>- Forward all applicable data and reports to the Design Engineer <b>as per the inspection schedule outlined in Table 3.1 of the OMS Manual</b></li> </ul>	
<b>Tailings Pond</b>	
<b>Daily Inspection</b>	
Tailings throughput	
Location of Tailings deposition and approx. length of exposed beach	
Condition of Tailings Beach (e.g. flat, sinkholes? Eroded?)	
<b>Weekly Inspection: Next Inspection on</b>	
Pond Water Level	
Freeboard distance between Crest and Pond	
<b>Semi-Annually: Next Inspection on</b>	
Complete tailings and pond survey to check volumes stored (before spring freshet and winter)	
Additional Notes	
<b>Tailings Embankment</b>	
<b>Weekly Inspection: Next Inspection on</b>	
Estimate flow rates into monitoring sumps & note clarity	
Embankment Condition (e.g. cracks, bulging at toe, etc.)	
Condition of downstream embankments (note erosion, damage, evidence of instability)	
Additional Notes	
<b>Tailings Discharge Pipeline</b>	
<b>Daily Inspection</b>	
Tailings pipeline pressure gauge readings	
Check for wear on pipeline (location & degree of damage)	
Check for pipeline leakage or evidence of leakage (location & degree of leakage)	
T2 Dropbox Water level	
Check for presence of tailings in T2 Dropbox	
Inspect for blockage in all pipelines entering Dropbox	
Additional Notes	

TABLE B-1  
MOUNT POLLEY MINING CORPORATION  
MOUNT POLLEY MINE  
TAILINGS STORAGE FACILITY  
INSPECTION LOG

Printed on: Mar-06-06  
Revised on: Dec 20, 2004

\\Server1\data\Enviro\Mount Polley\Tailings Management\OMS MANUAL\2006\TabB-1 Inspection 1

Reclaim Pipeline	
<b>Daily Inspection</b>	
Daily flow rate in reclaim pipeline	
Total daily volume pumped in reclaim pipeline.	
Reclaim pipeline pressure gauge readings at pump and discharge manifold	
Check for wear on pipeline (location & degree of damage)	
Check for pipeline leakage or evidence of leakage (location & degree of leakage)	
Inspect for blockage in all pipelines entering the Booster sump	
Check reclaim barge and note condition of pumps, de-icing equipment, mooring, lighting and walkway	
<b>Weekly Inspection: Next Inspection on</b>	
Barge Elevation	
Inspect ball joint connection (is the water elevation near the joint? Does the pad need to be raised?)	
Additional Notes	
Sediment Ponds	
<b>Daily Inspection</b>	
Check for blockage in manhole pipelines	
<b>Weekly Inspection: Next Inspection on</b>	
Water Level in Mill Site Sump	
Water Level in Southeast Sediment Pond	
Estimate flow exiting through Mill Site Sump manhole	
Estimate flow exiting through SE Sed. Pond manhole	
Condition of pond embankments (note erosion, damage, evidence of instability)	
Check drainage ditches for obstructions (note damaged areas and erosion)	
Additional Notes	

TABLE B-1  
MOUNT POLLEY MINING CORPORATION  
MOUNT POLLEY MINE  
TAILINGS STORAGE FACILITY  
INSPECTION LOG

Printed on: Mar-06-06  
Revised on: Dec 20, 2004

\\Server1\data\Envirom\Mount Polley\Tailings Management\OMS MANUAL\2006\TabB-1 Inspection I

<b>Seepage Collection Ponds</b>	
<b>Weekly Inspection: Next Inspection on</b>	
Water Level in Main and Perimeter collection pond	
Average pumpback flow rate from each recycle pump	
Check for blockage in pipelines leading in and out of ponds	
Check that seepage return pumps are operating.	
Condition of pond embankments (note erosion, damage, evidence of instability)	
Downstream of Embankment (note erosion, seepage, piping, etc.)	
Additional Notes	
<b>Instrumentation</b>	
<b>Monthly Inspection: Next Inspection on</b>	
Collect piezometer readings and barometric pressure. (Weekly during Construction Program)	
Check for displacements in inclinometer boreholes using 'poor boy' slope inclinometer (Twice-Monthly during Construction on Main Embankment)	
<b>Quarterly Inspection: Next Inspection on</b>	
Check condition of survey and surface movement monuments (Clear of vegetation and debris)	
Measure embankment displacements with surface movement monuments	
<b>Annual Inspection: Next Inspection on</b>	
Check displacements in inclinometer boreholes using probe	
Measure groundwater levels in monitoring wells. Forward information to Environmental Superintendent	
Take water samples from groundwater wells as directed by Environmental Superintendent	
Additional Notes	

Rev 0: Issued for OM&S Manual

TABLE C-1

MOUNT POLLEY MINING CORPORATION  
MOUNT POLLEY MINE

TAILINGS STORAGE FACILITY  
PIEZOMETER DATA SHEET

Printed on: Mar-06-06

\\Server1\data\Enviro\Mount Polley\Tailings Management\OMS MANUAL\2006\TabC-1 Piezo Log\_r Revised on: Dec 6, 2004

<b>INSPECTOR:</b>			
<b>DATE:</b>			
<b>WEATHER CONDITON:</b>			
Piezometer ID	Barometric Pressure (inches Hg)	Frequency Reading (Lu)	Temperature (°C)



TABLE C-2

MOUNT POLLEY MINING CORPORATION  
MOUNT POLLEY MINE

TAILINGS STORAGE FACILITY  
SLOPE INCLINOMETER DATA SHEET

Printed on: Mar-06-06

\\Server1\data\Enviro\Mount Polley\Tailings Management\OMS MANUAL\2006\TabC-2 Slope Inclinator Revised on: Dec 6, 2004

<b>INSPECTOR:</b>						
<b>DATE:</b>						
<b>WEATHER CONDITON:</b>						
Depth	A0	A180	B0	B180	A Deviation	B Deviation



TABLE C-3

MOUNT POLLEY MINING CORPORATION  
 MOUNT POLLEY MINE  
 TAILINGS STORAGE FACILITY  
 SURVEY DATA SHEET

Printed on: Mar-06-06  
 Revised on: Dec 9, 2004

\\Server1\data\enviro\Mount Polley\Tailings Management\OMS MANUAL\2006\TabC-3 Survey\_r0.xls\Sheet1

Monument	Date	Monitoring and Survey Data			Displacements Between Readings (m)				Total Displacements (m)				
		Comments	$N_n$	$E_n$	$EI_n$	DN	DE	DEI	$D_{yz}$	DN	DE	DEI	$D_{xyz, total}$

Notes:

- 1. Calculate displacements as follows:
- 2. NM- Not Measured

Total Displacements from initial survey

$DN = N_n - N_0$   
 $DE = E_n - E_0$   
 $DEI = EI_n - EI_0$   
 $D_{xy, total} = (DN^2 + DE^2)^{1/2}$   
 $D_{xyz, total} = (DN^2 + DE^2 + DEI^2)^{1/2}$

Displacements between readings

$DN = N_{(n+1)} - N_n$   
 $DE = E_{(n+1)} - E_n$   
 $DEI = EI_{(n+1)} - EI_n$   
 $D_{xy} = (DN^2 + DE^2)^{1/2}$   
 $D_{xyz} = (DN^2 + DE^2 + DEI^2)^{1/2}$

Comments on calculations

- 1. Coordinate system is (Easting, Northing, Elevation) = f(x,y,z).
- 2. Coordinate system is as shown on Drawings.

Rev 0 - Issued for OMS Manual





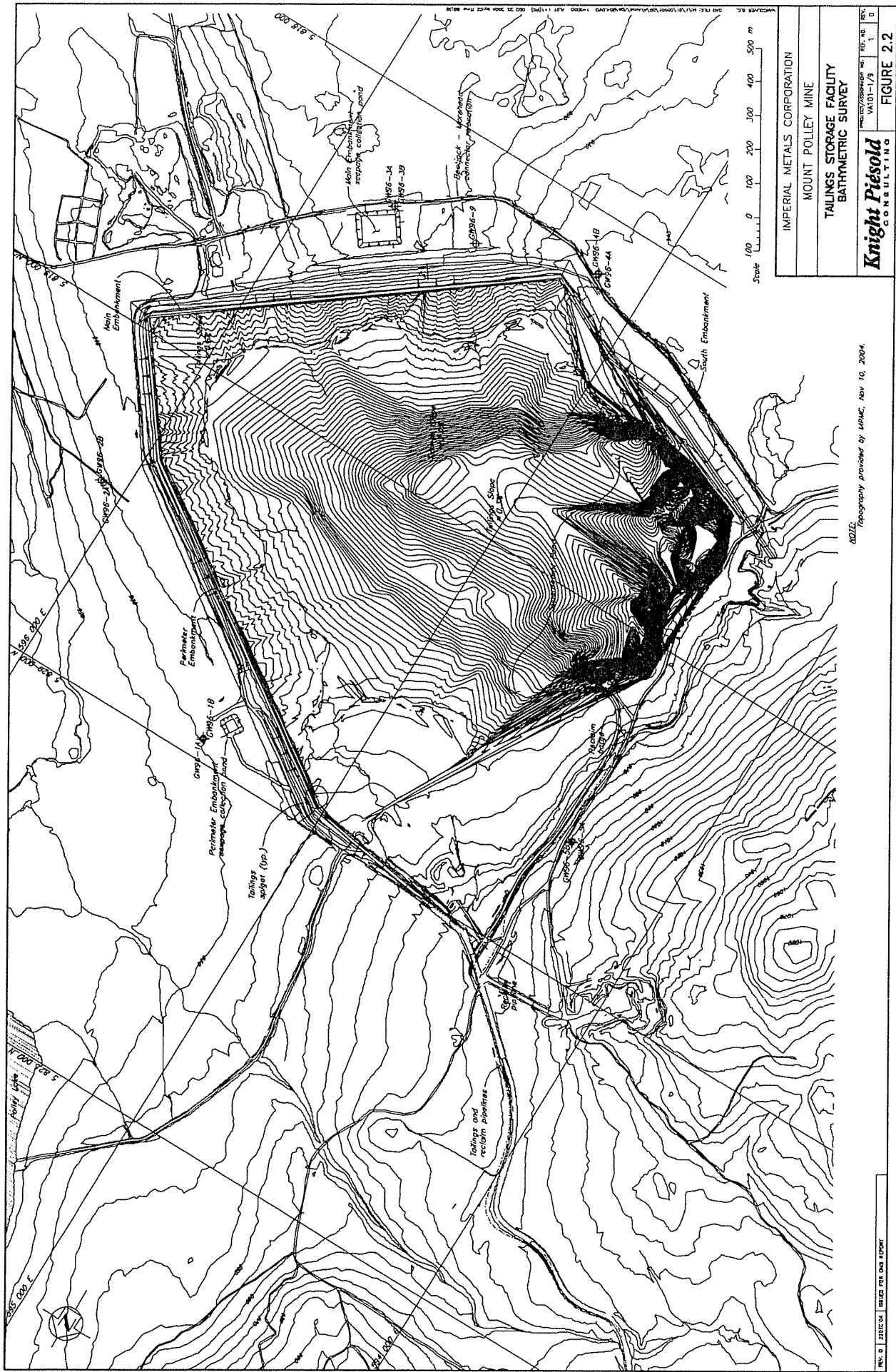

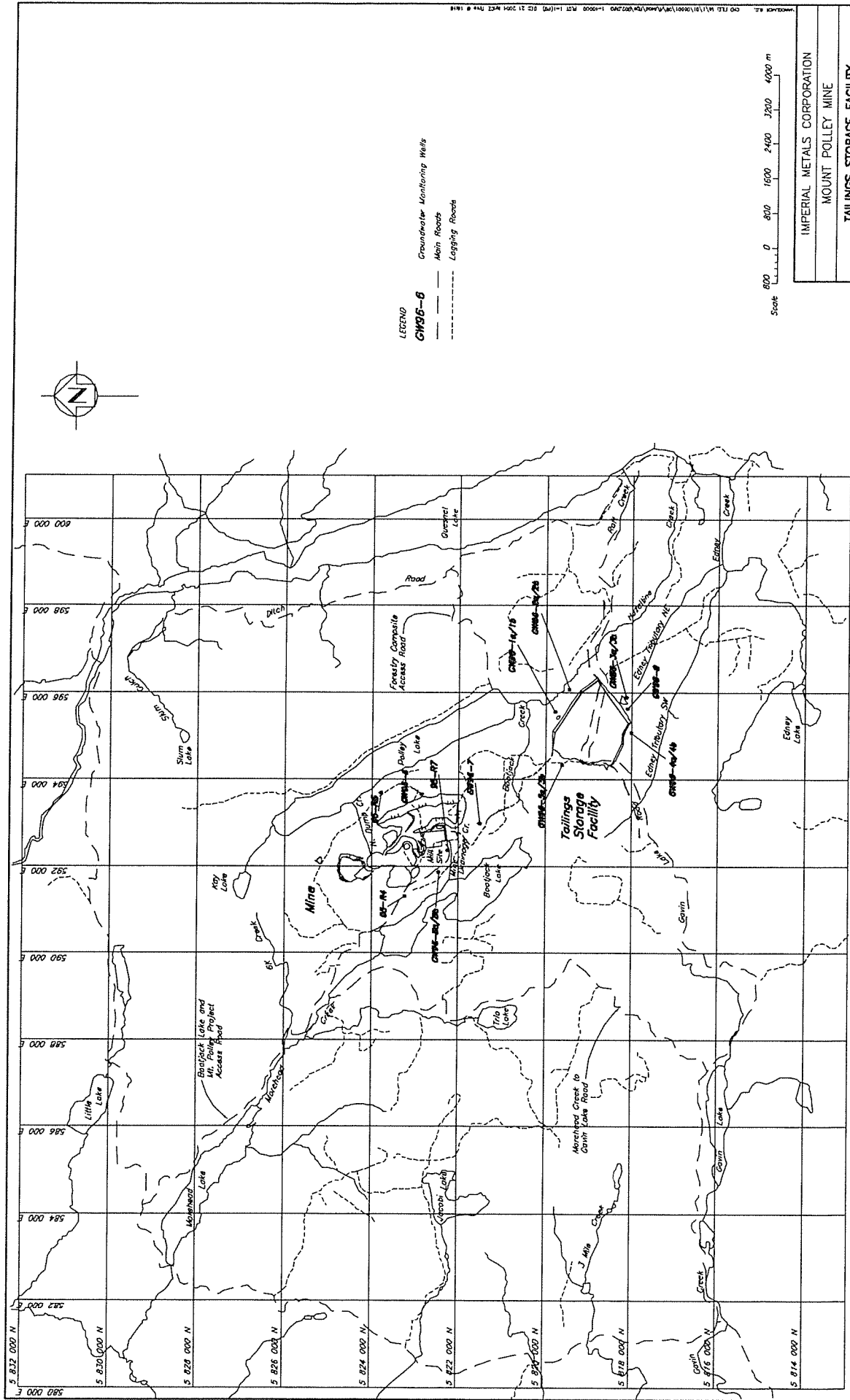

LEGEND  
**GMW-6** Groundwater Monitoring Wells  
 --- Main Roads  
 - - - - Logging Roads

Scale 0 800 1600 2400 3200 4000 m

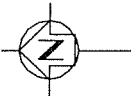

IMPERIAL METALS CORPORATION  
 MOUNT POLLEY MINE  
 TAILINGS STORAGE FACILITY  
 GROUNDWATER MONITORING WELL LOCATIONS

**Knight Piesold**  
 CONSULTING

PROJECT/ASSAY NO.	REV.	DATE
VA01-1/3	1	0

FIGURE 3.2

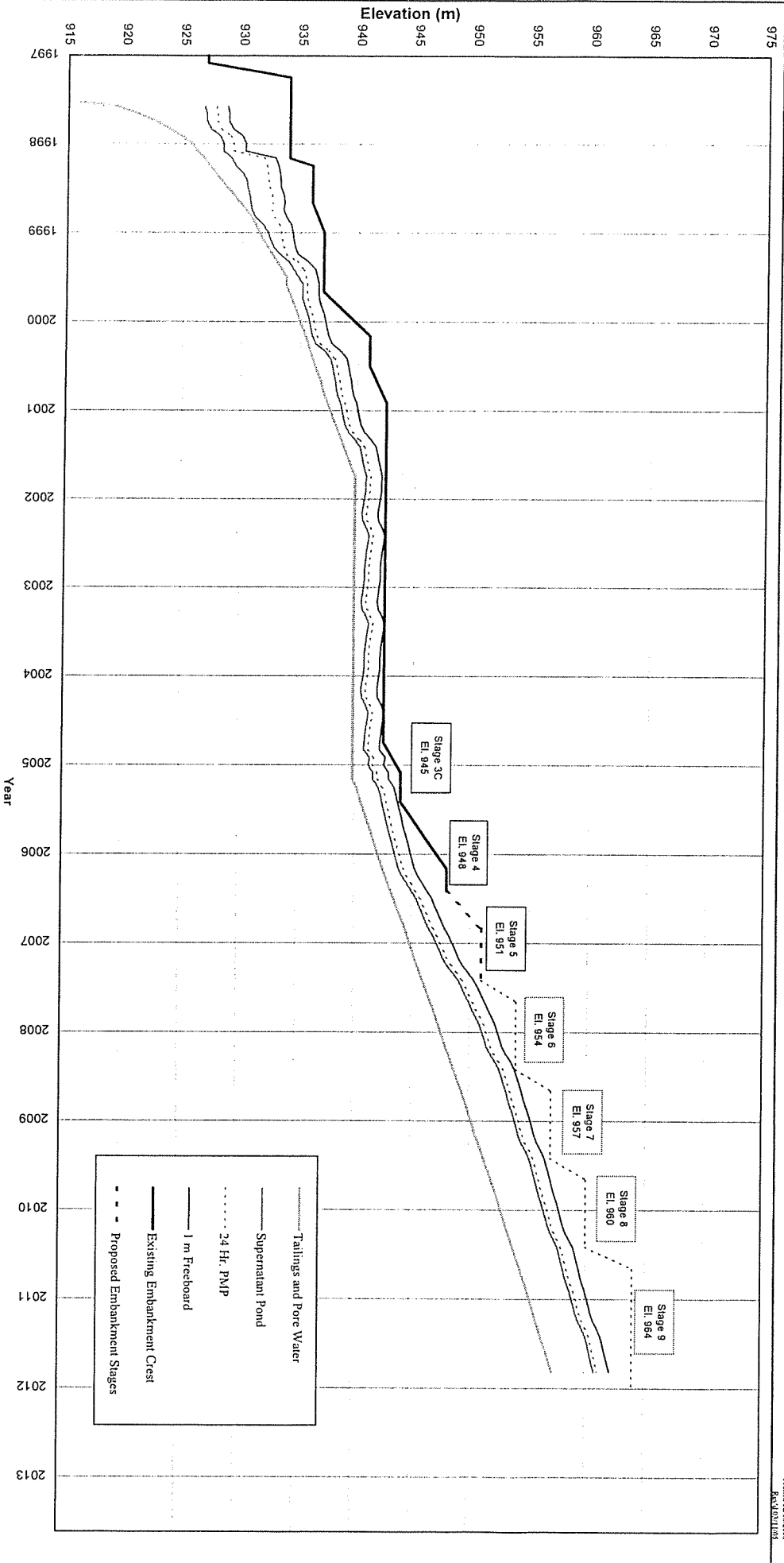

Notes:

1. Production rate is estimated 20,000 tpd.
2. Projected bulk tailings dry density is 1.36 t/m<sup>3</sup> for tailings reporting to the TSF after August 2000.
3. The filing schedule will be updated as required to reflect actual mine throughput and the supernatant pond volume.

Rev 0 - Issued for Report

MOUNT POLLEY MINING CORPORATION	
MOUNT POLLEY MINE	
TAILINGS STORAGE FACILITY	
FILING SCHEDULE	
PROJECT NO.	REF. NO. / REV.
VA 10-1-19	1 / 0
FIGURE 3.1	

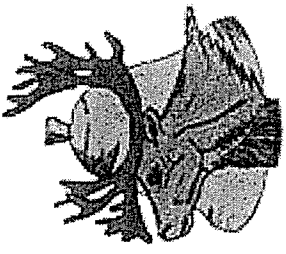
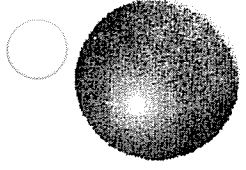

Mount Polley Mines

# *Mount Polley Project* Tailings Facility Summary

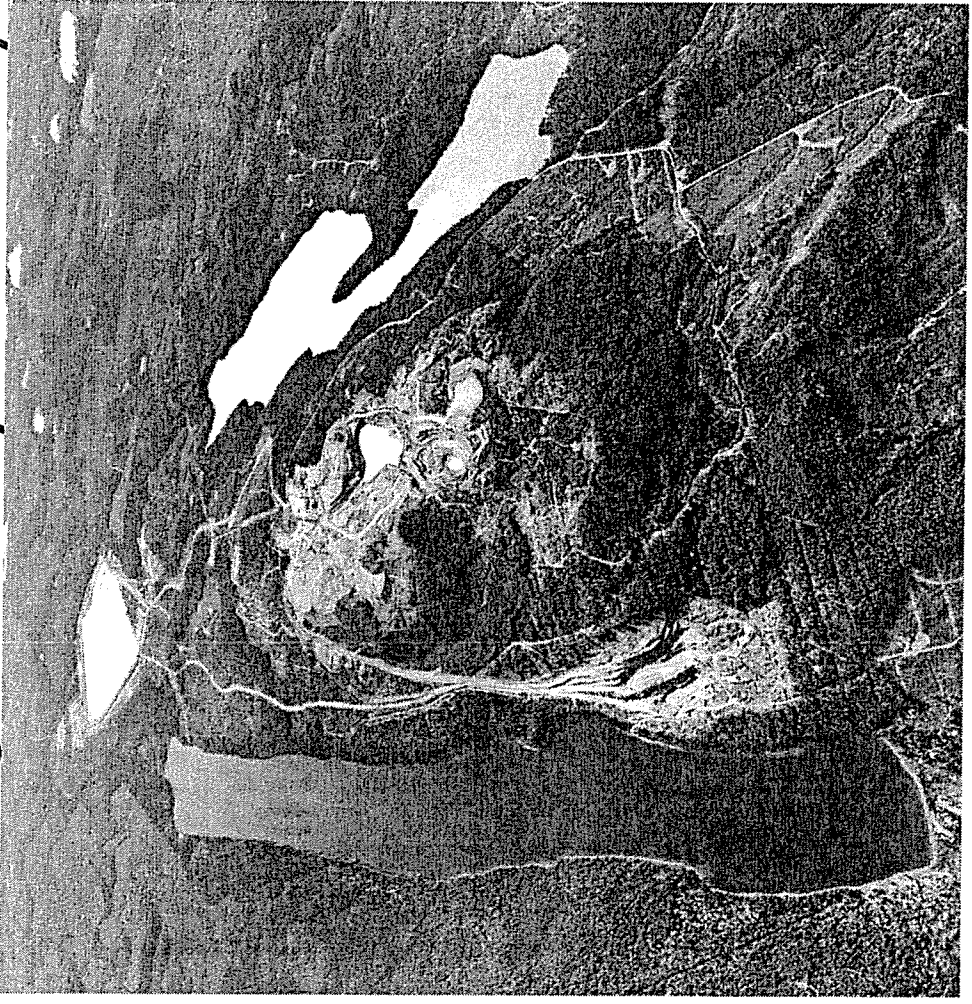

February 2, 2006

Knight Piesold ref #: 101-01/12



# *Overview of Presentation*

- General information
- Project Background
- Stage 5 Construction Schedule
- On-going Operations and Monitoring
- Wight Pit Dewatering

# General Information

- Mount Polley Project, 2001 Air photo

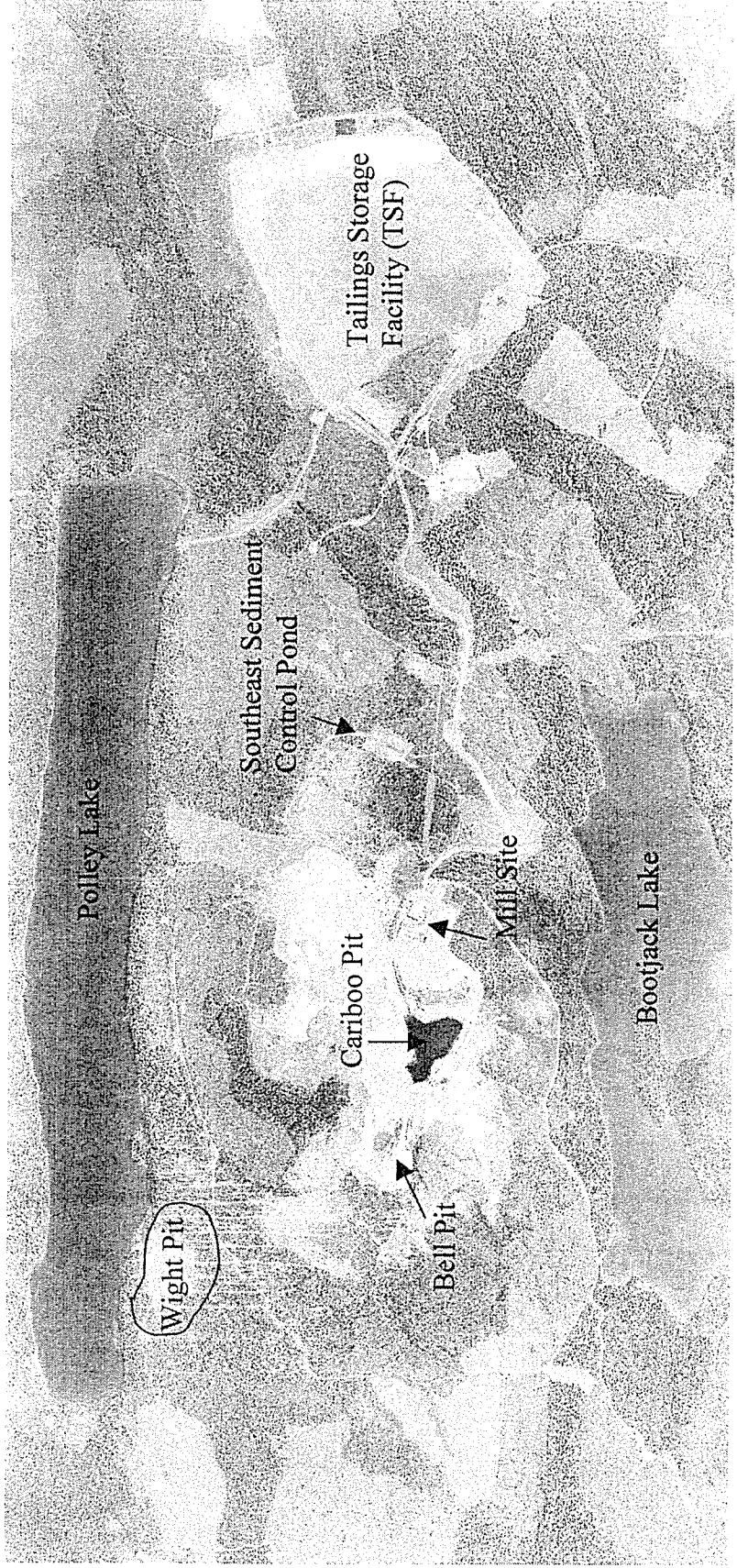



# *General Information*

- Production started June 1997
- Care and Maintenance status October 2001 to March 2005
- Regular inspections
- Start up March 2005
- Stage 4 Tailing Storage Facility (TSF) construction per existing permits to El. 948m from May 2005 to present
- Additional Mines Branch permits required for on-going expansion of TSF
- Stage 5 crest to be constructed to El. 951m
- Stage 4 raise was an upstream cap
- Stage 5 raise will be a modified centerline construction



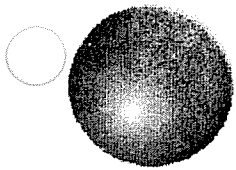

# Project Background – Hydrometeorology (Update Required)

- Mean annual precipitation of 755mm at TSF
- Probable Maximum Precipitation (PMP) is 203mm

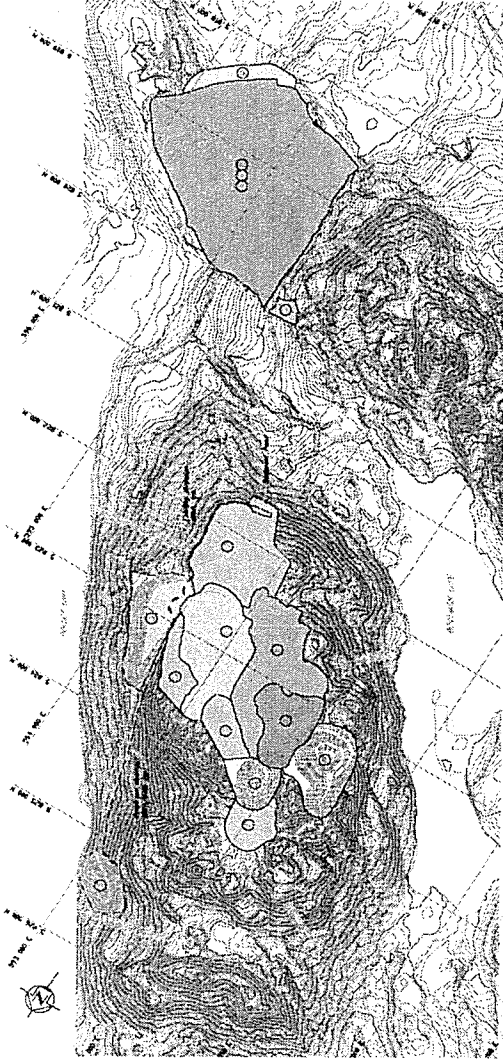

Station	Year	Area	Area
1	1997	100	100
2	1998	100	100
3	1999	100	100
4	2000	100	100
5	2001	100	100
6	2002	100	100
7	2003	100	100
8	2004	100	100
9	2005	100	100
10	2006	100	100
11	2007	100	100
12	2008	100	100
13	2009	100	100
14	2010	100	100
15	2011	100	100
16	2012	100	100
17	2013	100	100
18	2014	100	100
19	2015	100	100
20	2016	100	100
21	2017	100	100
22	2018	100	100
23	2019	100	100
24	2020	100	100
25	2021	100	100
26	2022	100	100
27	2023	100	100
28	2024	100	100
29	2025	100	100
30	2026	100	100
31	2027	100	100
32	2028	100	100
33	2029	100	100
34	2030	100	100

Station	Year	Area	Area
1	1997	100	100
2	1998	100	100
3	1999	100	100
4	2000	100	100
5	2001	100	100
6	2002	100	100
7	2003	100	100
8	2004	100	100
9	2005	100	100
10	2006	100	100
11	2007	100	100
12	2008	100	100
13	2009	100	100
14	2010	100	100
15	2011	100	100
16	2012	100	100
17	2013	100	100
18	2014	100	100
19	2015	100	100
20	2016	100	100
21	2017	100	100
22	2018	100	100
23	2019	100	100
24	2020	100	100
25	2021	100	100
26	2022	100	100
27	2023	100	100
28	2024	100	100
29	2025	100	100
30	2026	100	100
31	2027	100	100
32	2028	100	100
33	2029	100	100
34	2030	100	100

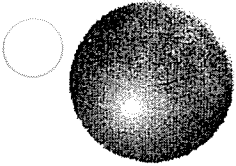

# Project Background – Water Management

- Site Water Management (Wight pit not shown)

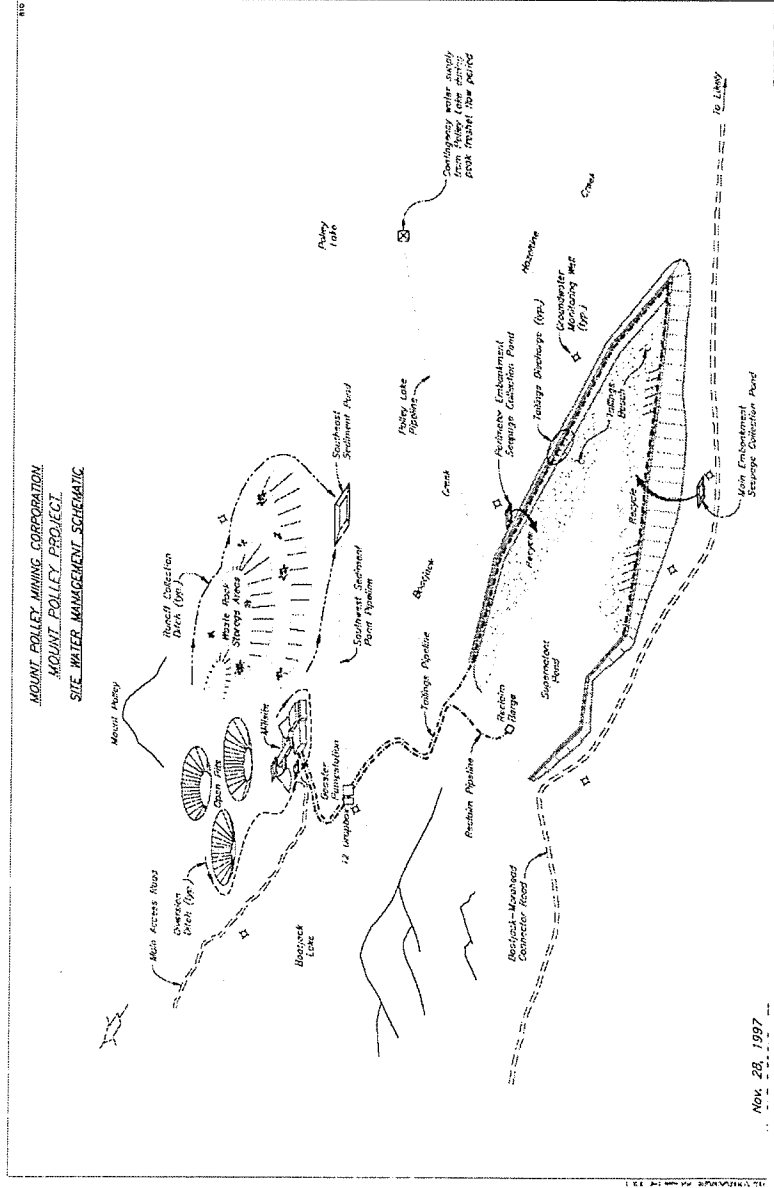

# Project Background – Water Balance (Update Required)

Typical water balance calculations for Wight Pit expansion:

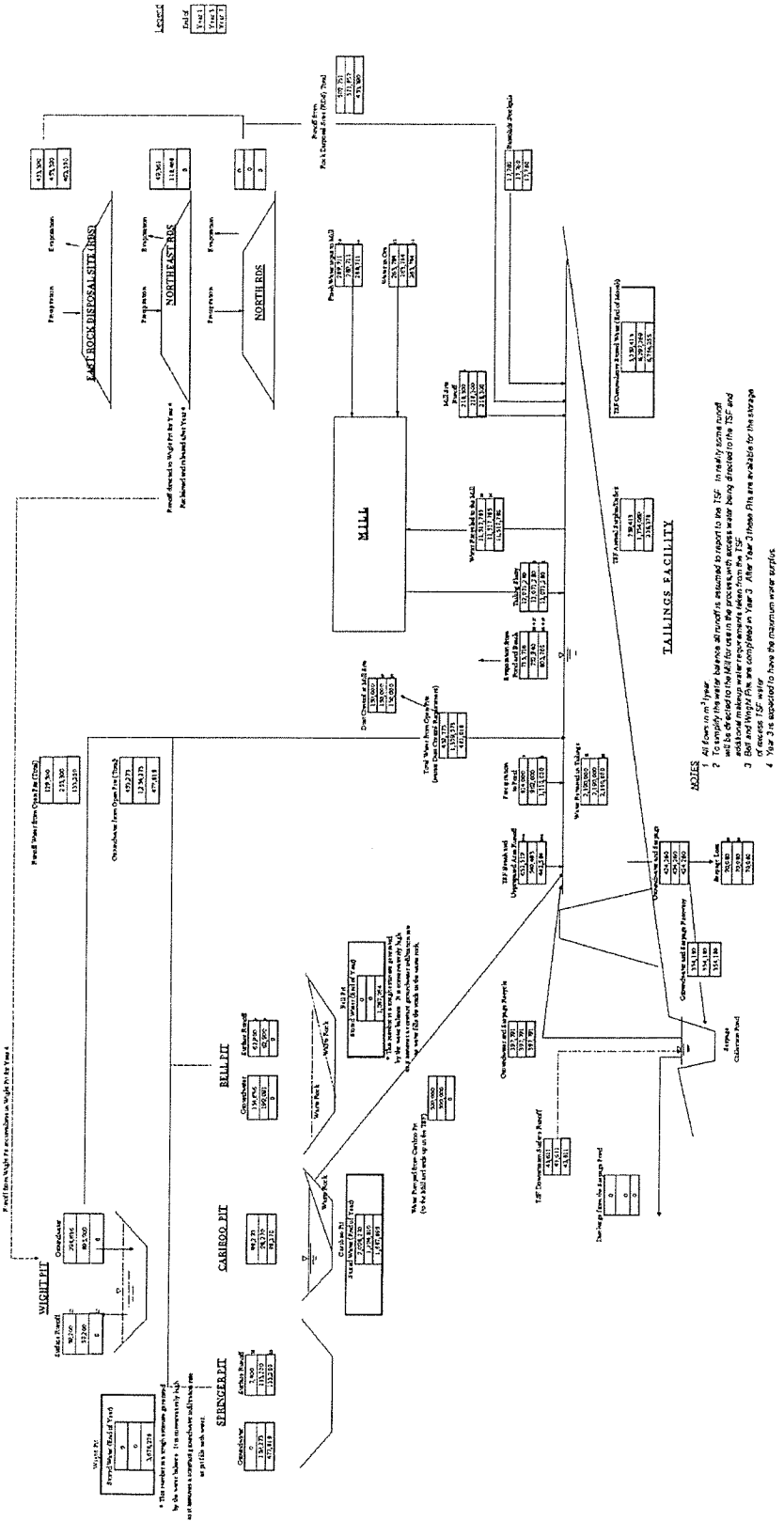

# TSF — Staged Development

◆ Proposed On-going Stages

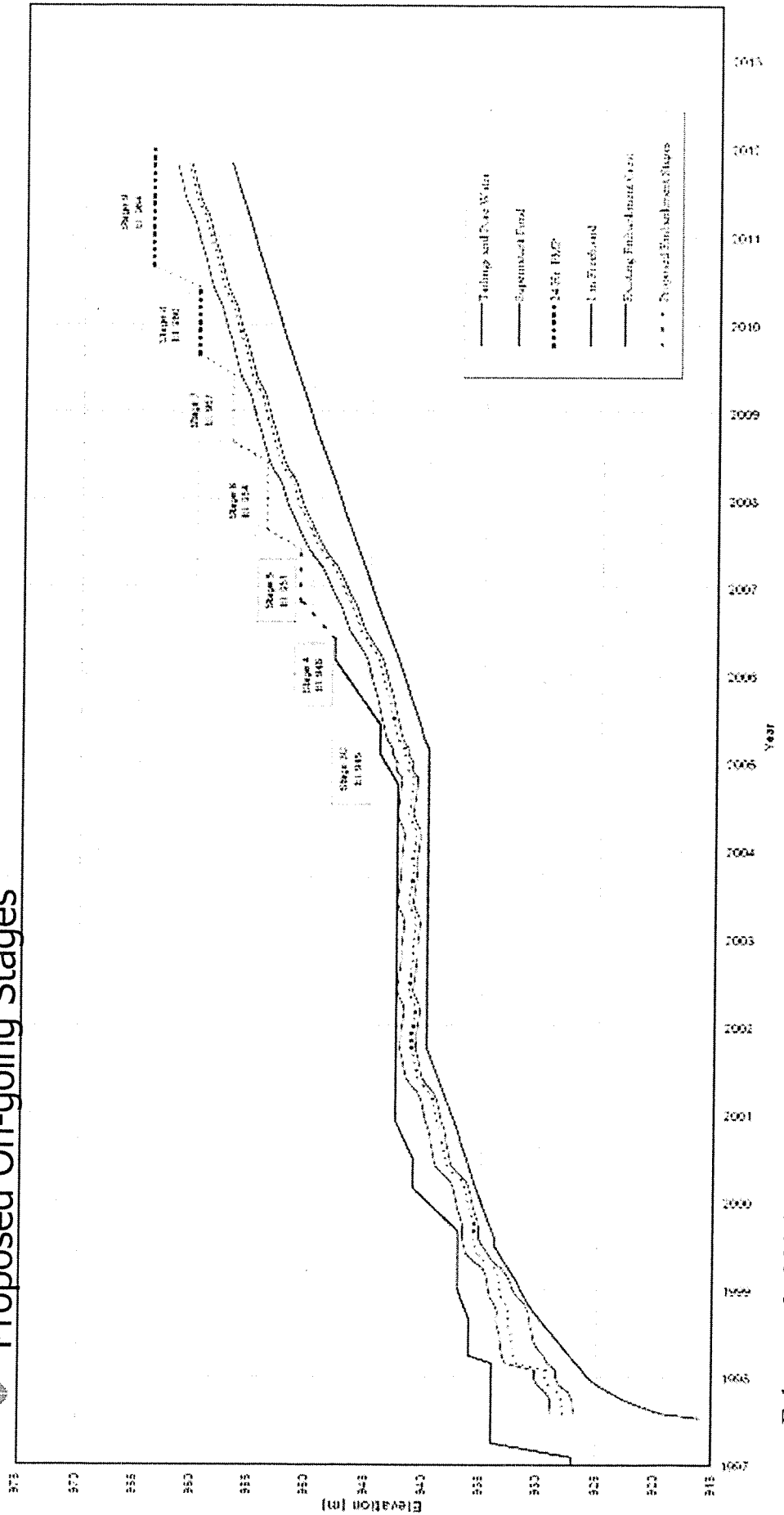

February 2, 2006

Knight Piesold ref #: 101-01/12

# Tailings Storage Facility

- Tailings Storage Facility (TSF) layout:

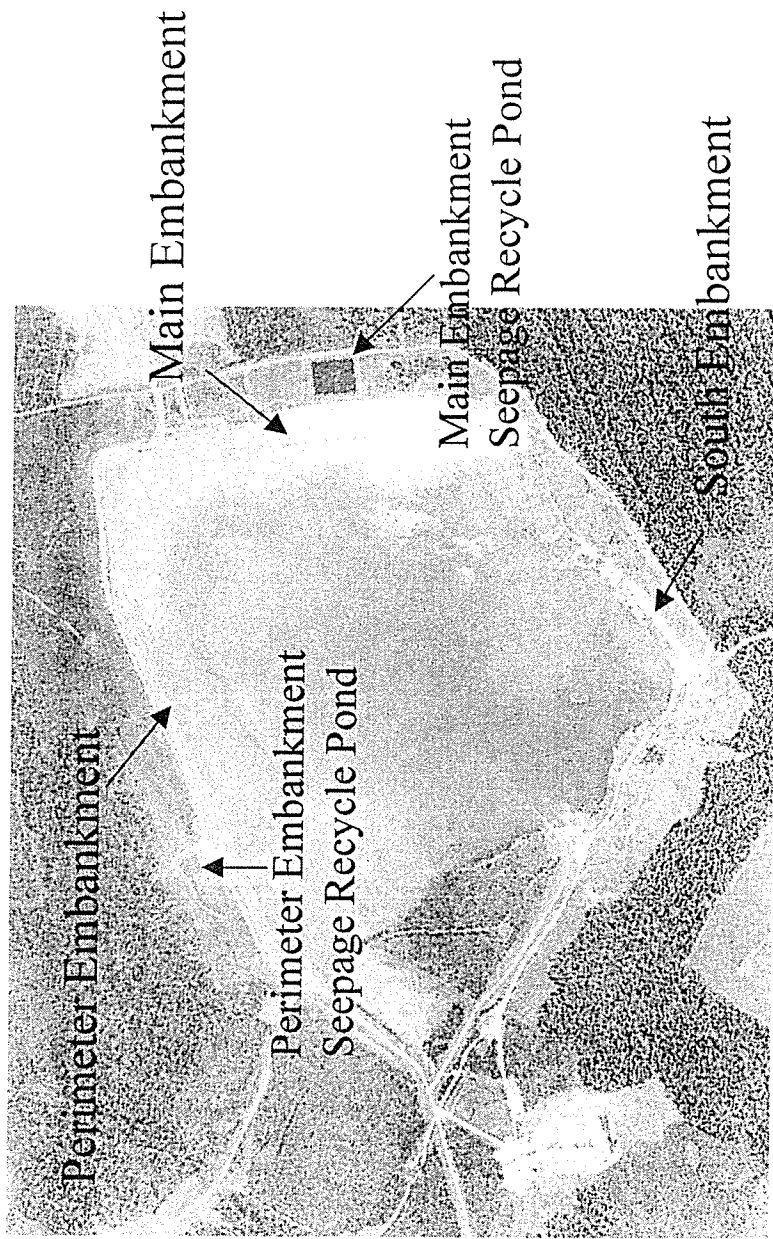

2001 Air Photo



# *Tailings Storage Facility*

- Currently Permitted:
  - Stage 1a/1b constructed to El. 934m in 1996/1997 – reviewed by Fred Matich
  - Stage 2a/2b constructed to El. 937m in 1998 – reviewed by Chuck Brawner
  - Stage 3a/3b constructed to El. 942.5m in 2000/2001 – reviewed by Chris Carr
  - Stage 3c constructed to El. 945m in 2004/2005 – reviewed by Chris Carr
  - Stage 4 construction to El. 948m on embankments in progress – Approved by Chris Carr
- Pending Permits:
  - On-going design and expansions to El. 965m
  - Stage 5 construction to El. 951m on embankments

# Project Background

## Main Geological X-sections

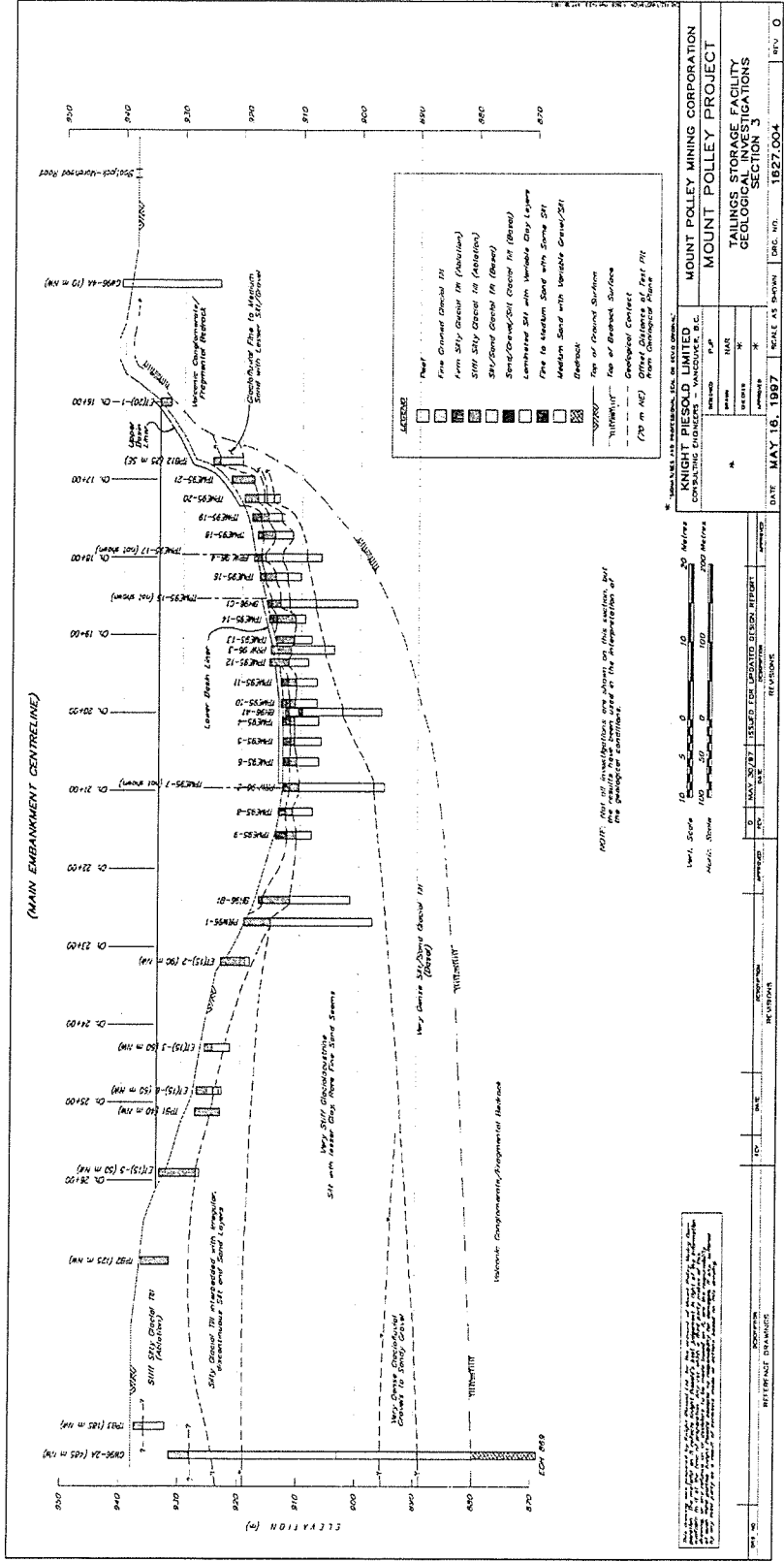
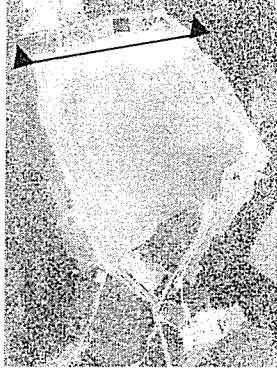

# Project Background

## South Geological X-sections

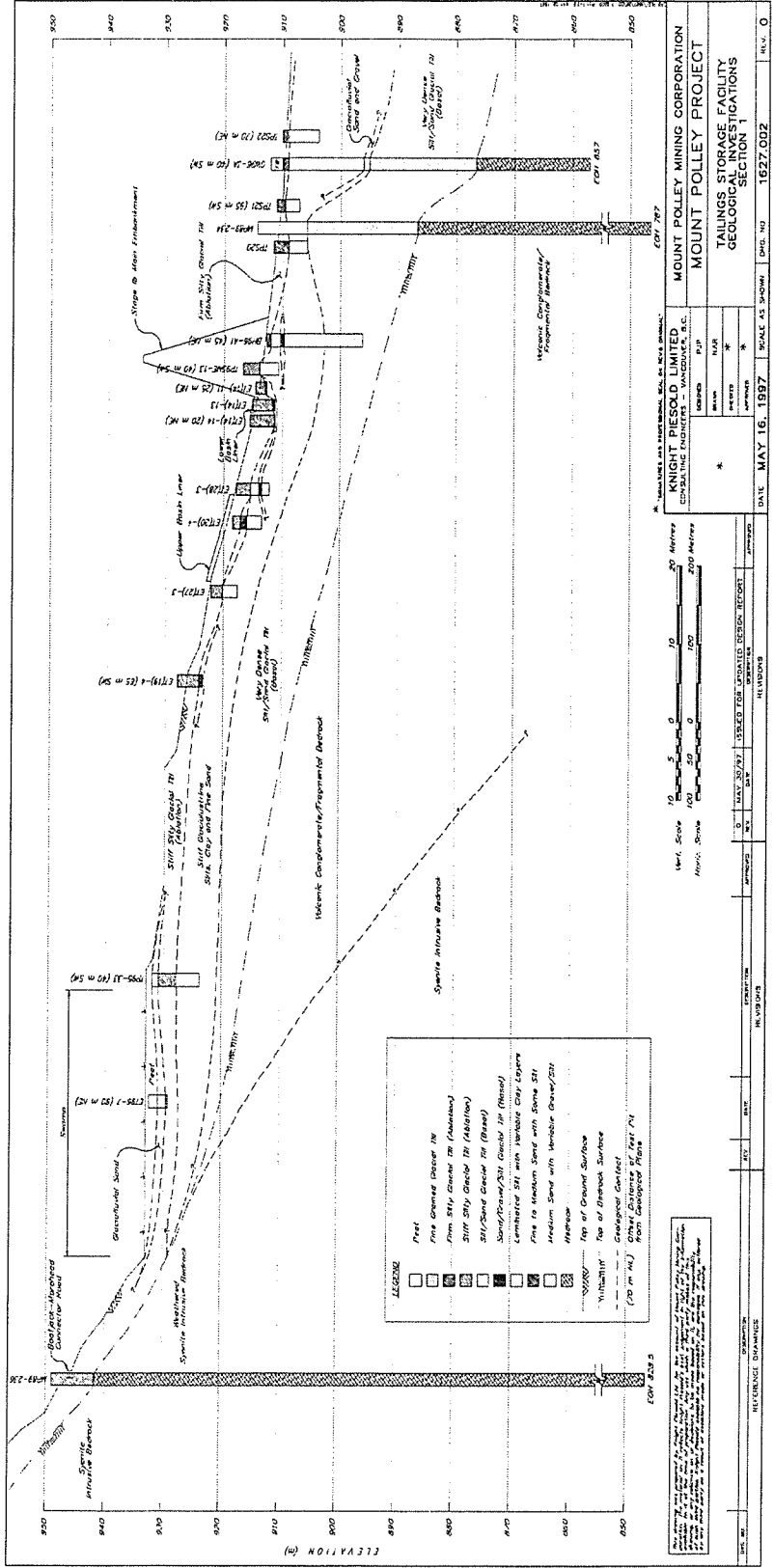
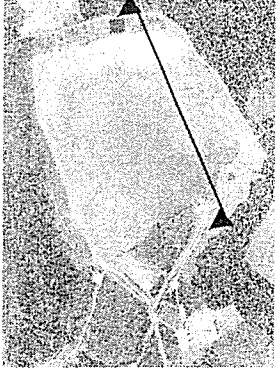

February 2, 2006

Knight Piesold ref #: 101-01/12



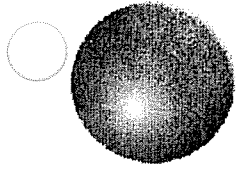

# Project Background – Tailings Properties



- Tailings Slurry:
  - Solid throughput: **20,000 tonnes per day**
  - Percent solids: **25 – 30%**
  - Solid Specific Gravity: **2.70**
  - In situ density: **1.44 tonne/m<sup>3</sup>**
  - Geochemical characteristics:

Sulphur (percent)	Paste pH	Acid Potential (kg CaCO <sub>3</sub> /t)	Neutralization Potential (kg CaCO <sub>3</sub> /t)	Net Neutralization Potential (kg CaCO <sub>3</sub> /t)
0.02	8.22	0.6	24.6	24.0

- Seepage water quality: **Ron Martel**

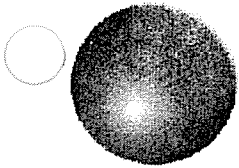

# Project Background – Tailings Properties

• Tailings PSA summary :

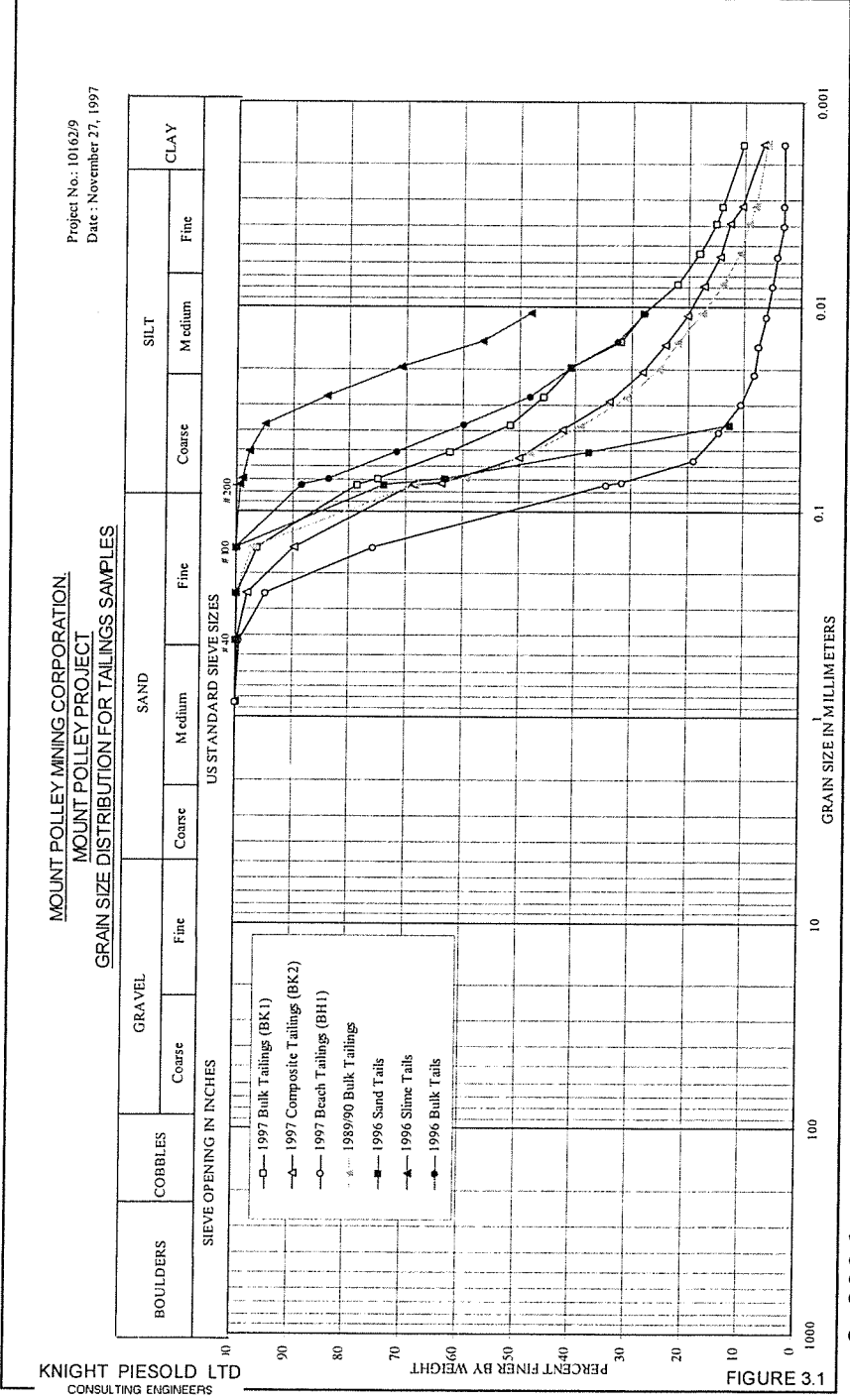

February 2, 2006

Knight Piesold ref #: 101-01/12

# *TSF – Stage 4 Sand Cell Construction*

● Cell dimensions: 18m x 150m

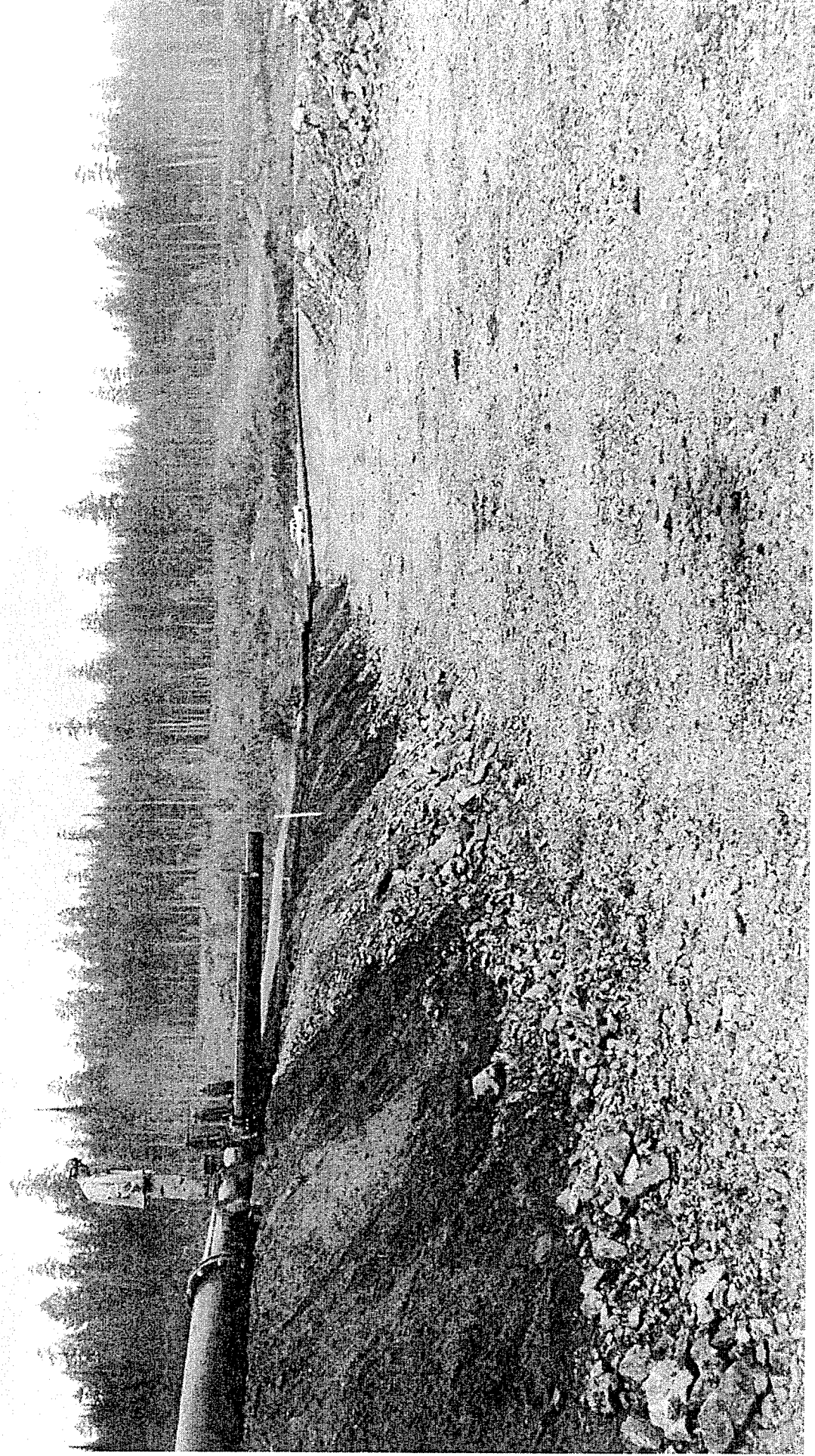

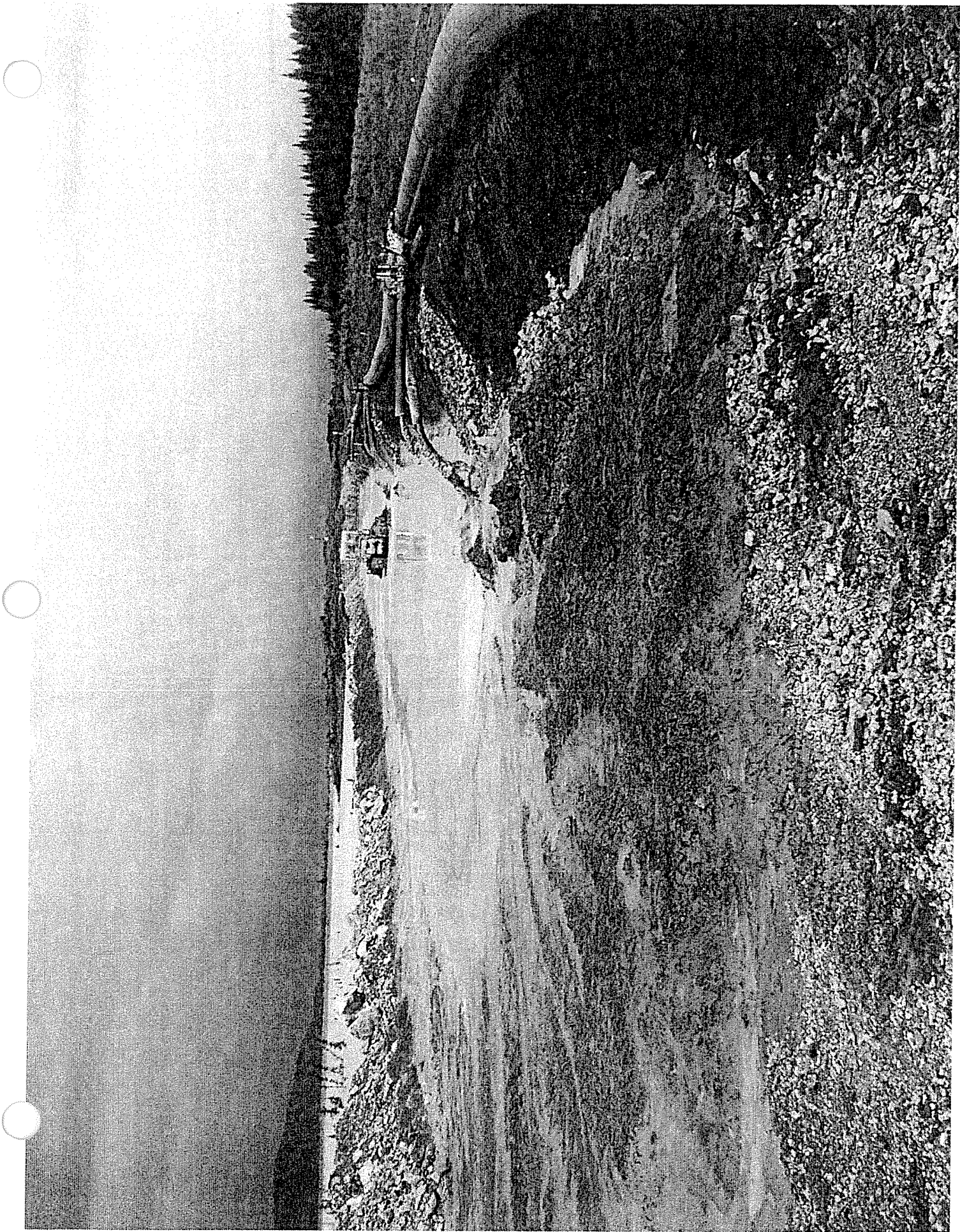

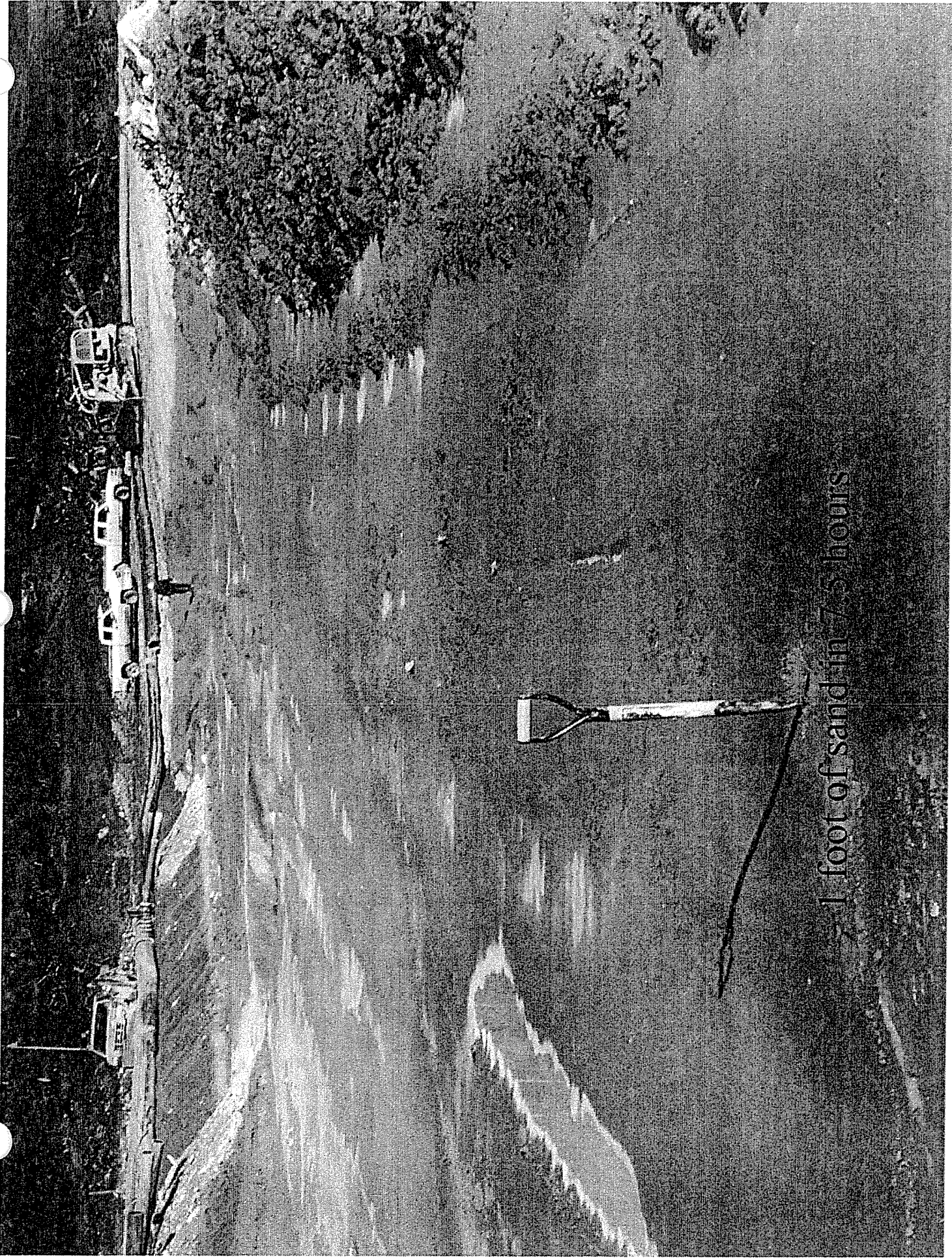

1 foot of sand in 7.5 hours

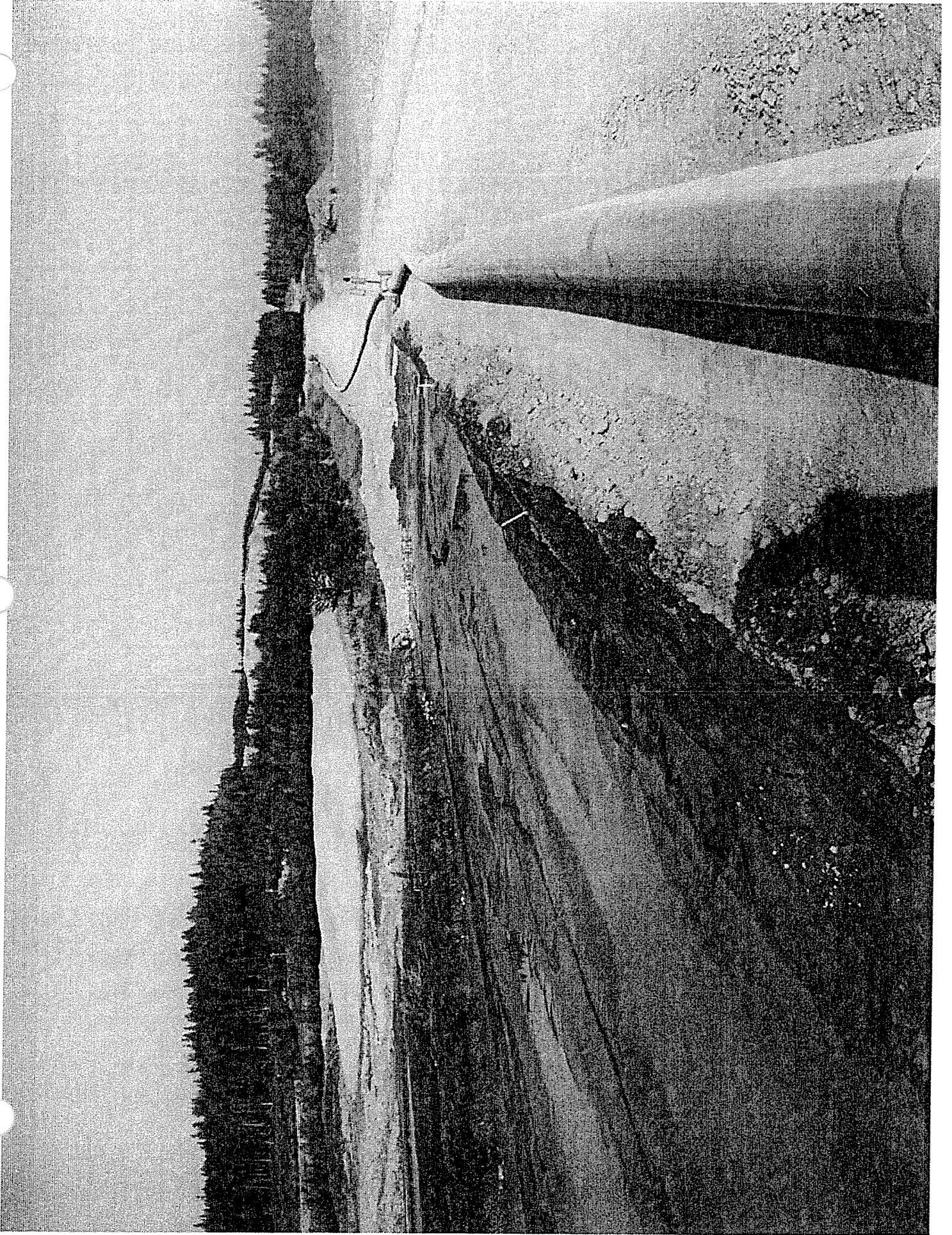

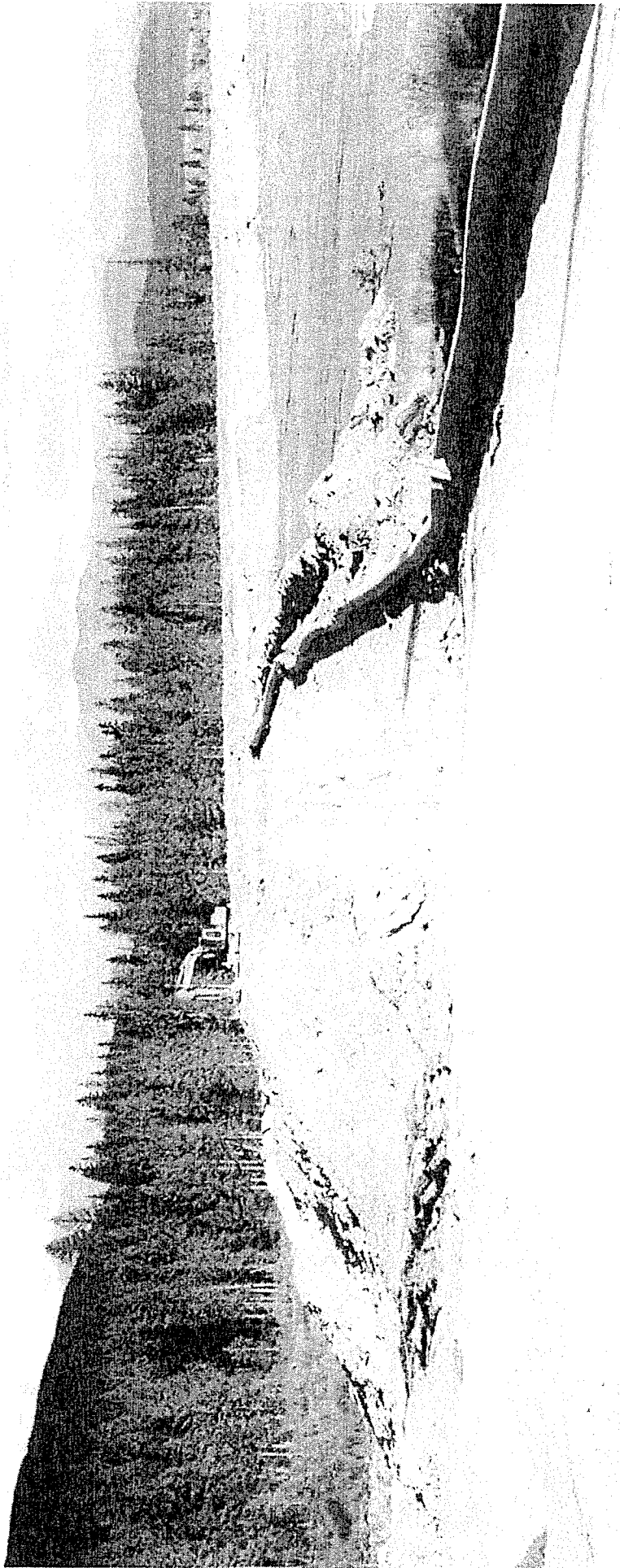

# TSF – Stage 5 Design

- ◆ Waste rock dump and haul road.

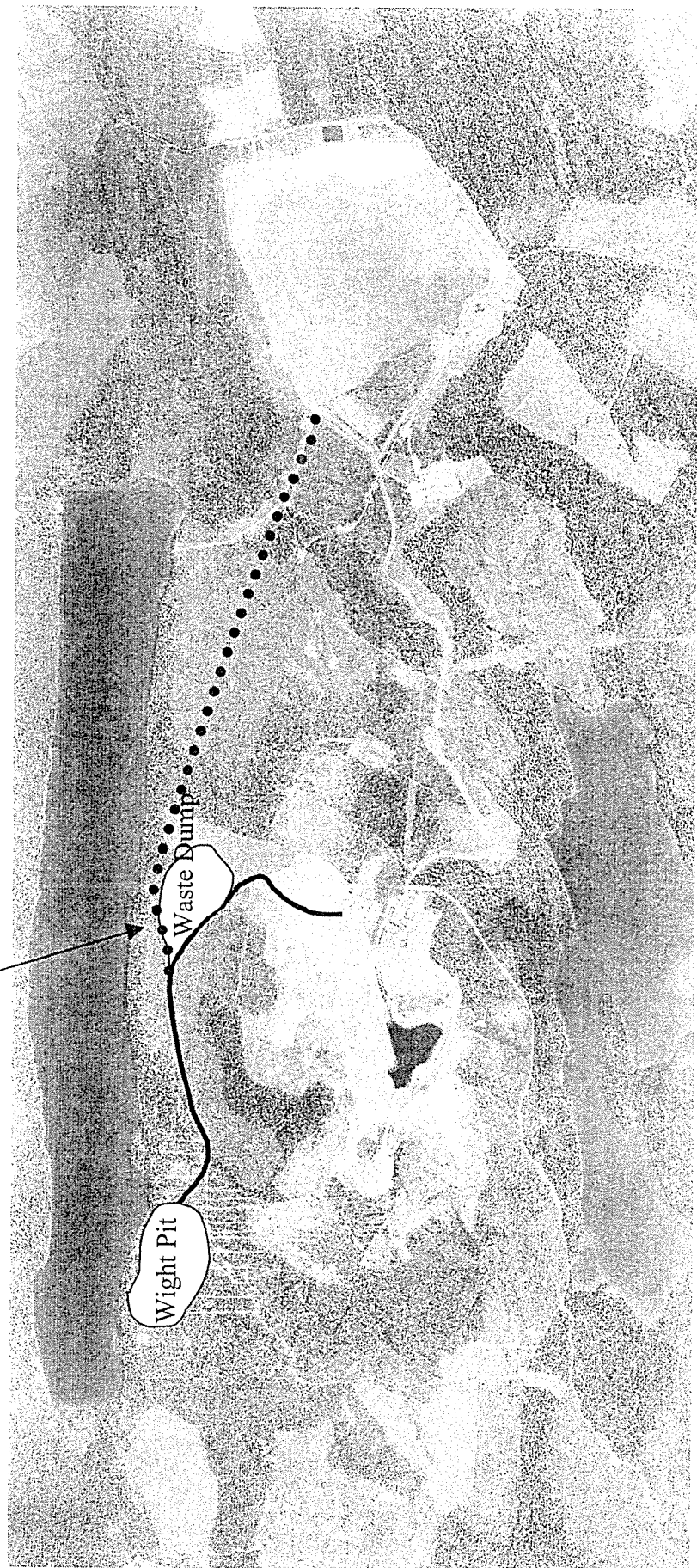



# Tailings Storage Facility

- ◆ Perimeter Embankment:  
Raise Zone C to El. 944m.

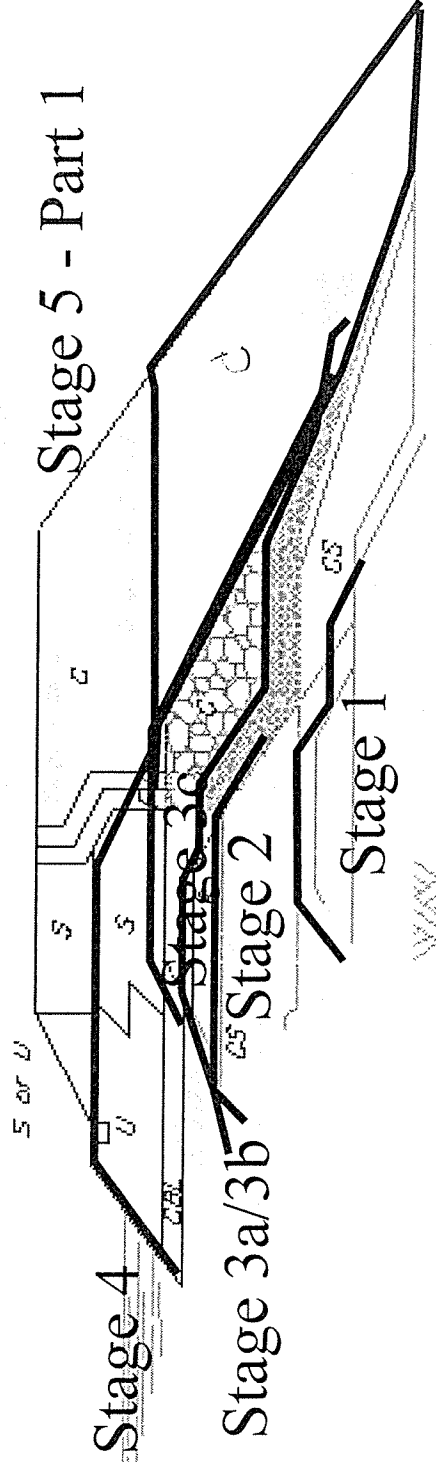

# Tailings Storage Facility

- ◆ Perimeter Embankment:  
Raise Zone C, S, F and T to El. 951 m. Zone C can be temporarily placed at the angle of repose.

Stage 5 - Part 2

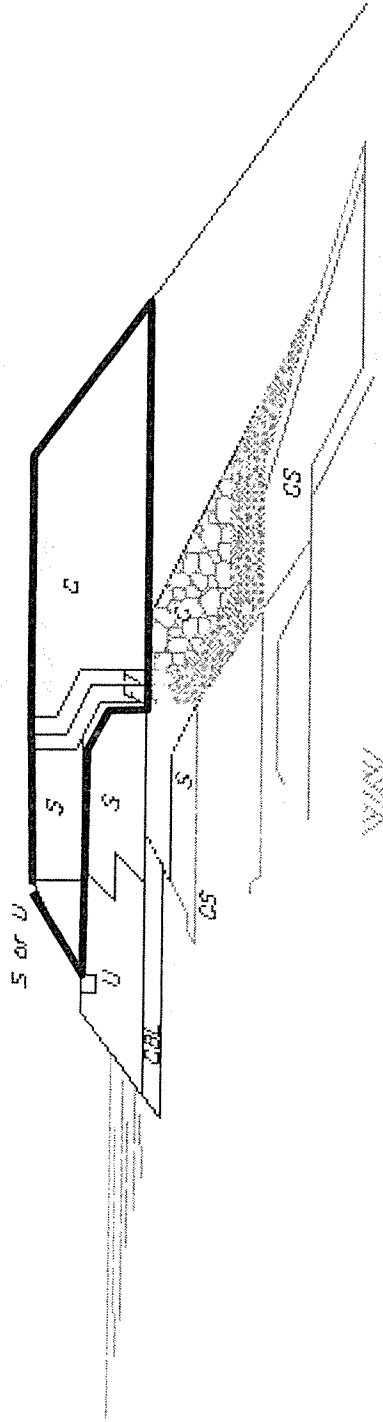

# Tailings Storage Facility

- Perimeter Embankment:

Place Zone C at 2:1

Stage 5 - Part 3

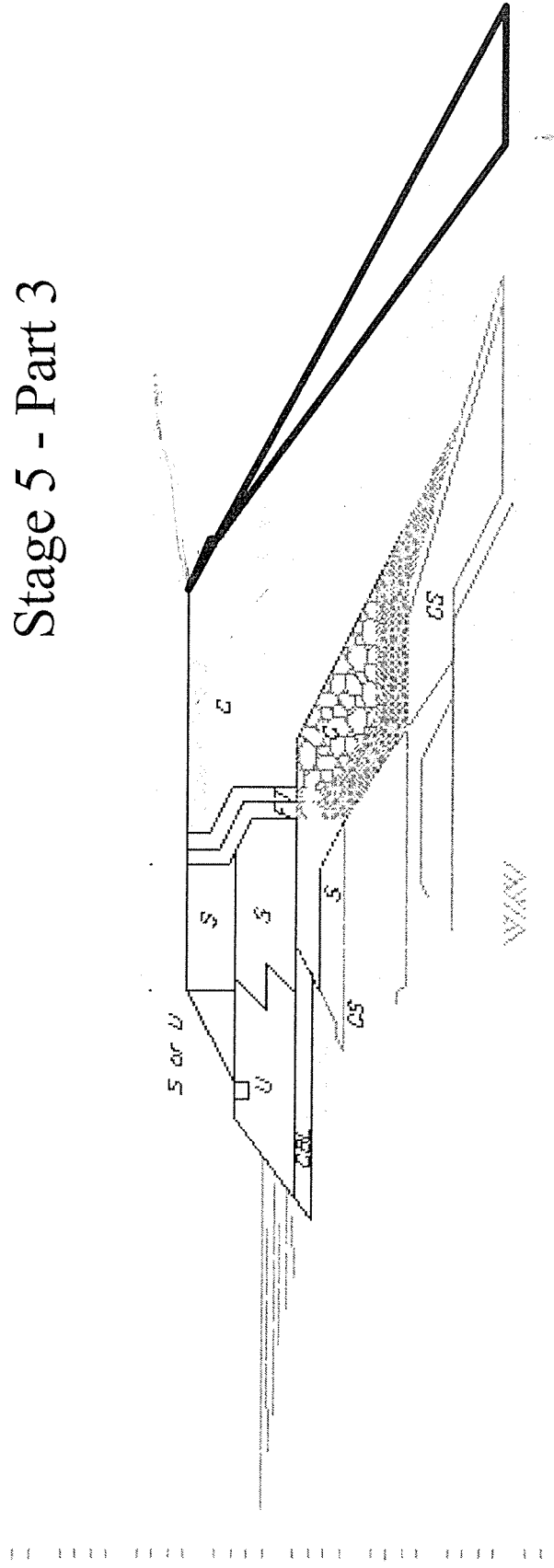

# Tailings Storage Facility

## ◆ Perimeter Embankment:

Zone C configuration options.

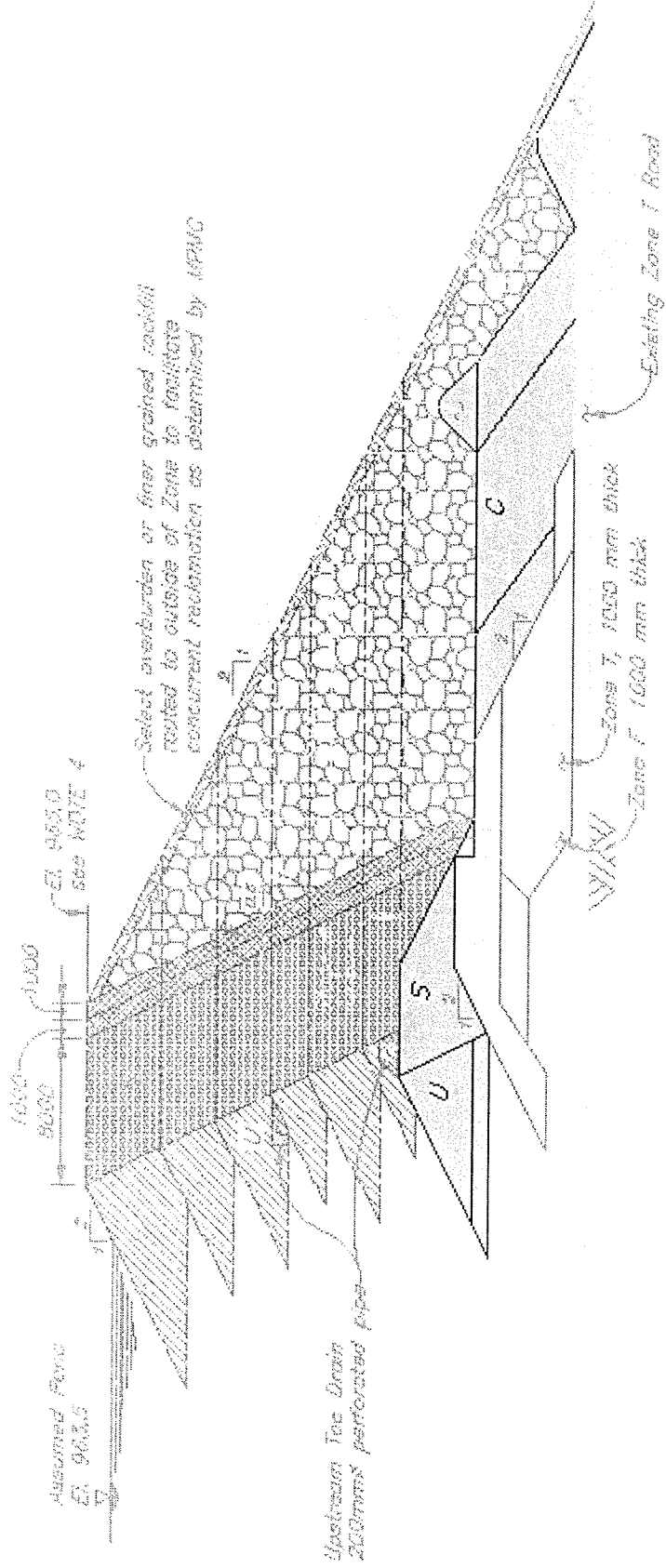

# Tailings Storage Facility

- Main Embankment:  
Place Zone C to El. 944m.

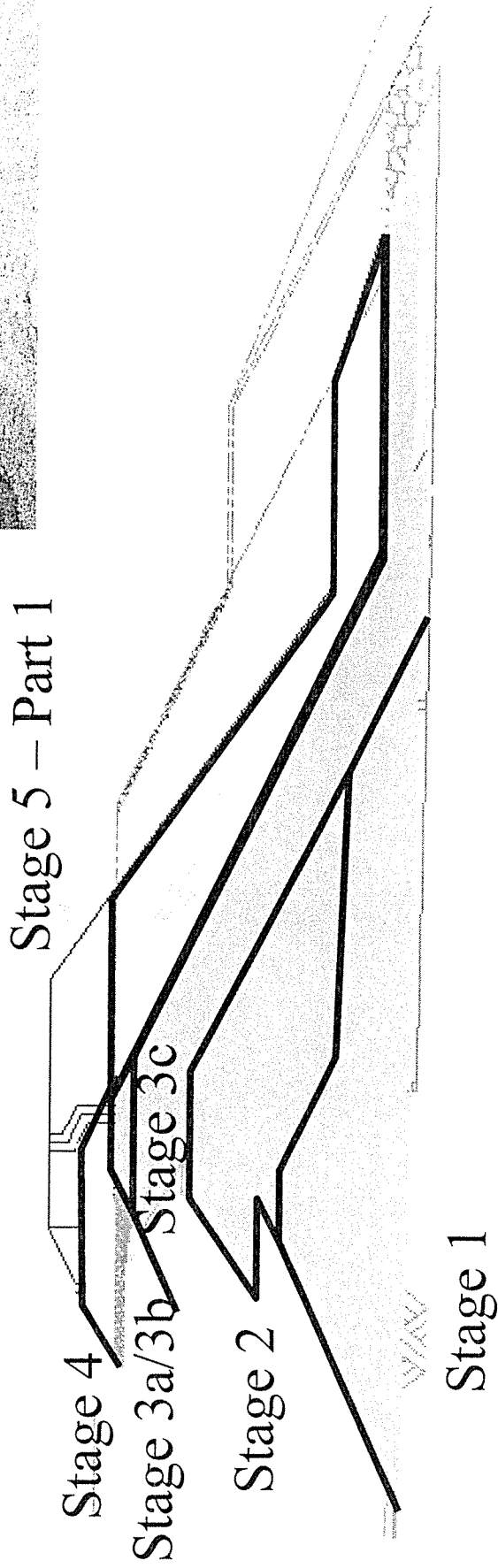

# Tailings Storage Facility

- ◆ Main Embankment:

Raise Zone C, S, F and T to El. 951 m. Zone C can be temporarily placed at the angle of repose.

## Stage 5 – Part 2

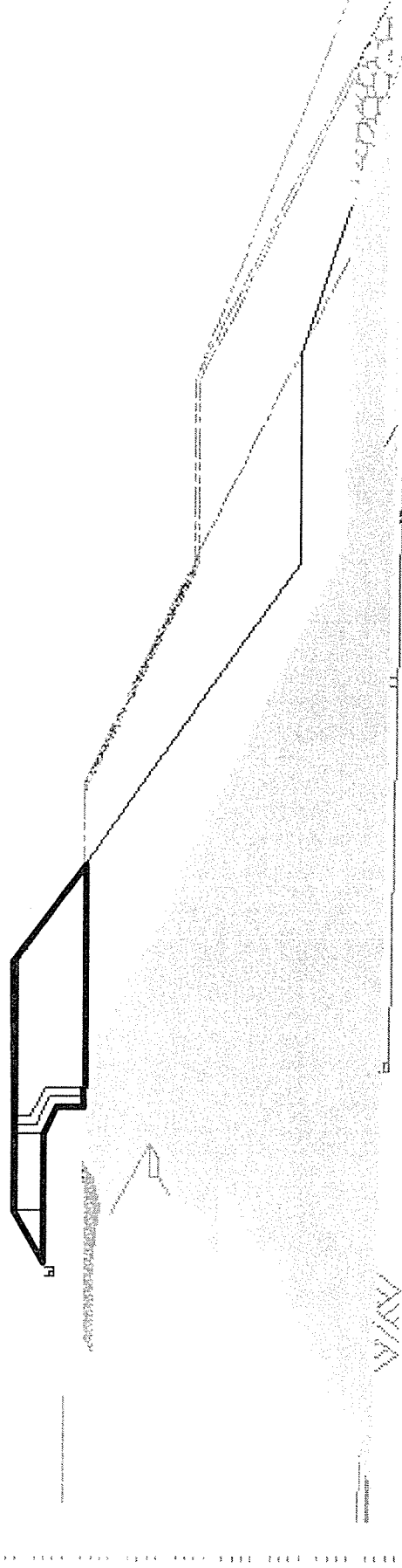

# Tailings Storage Facility

- Main Embankment:  
Place Zone C at 2:1

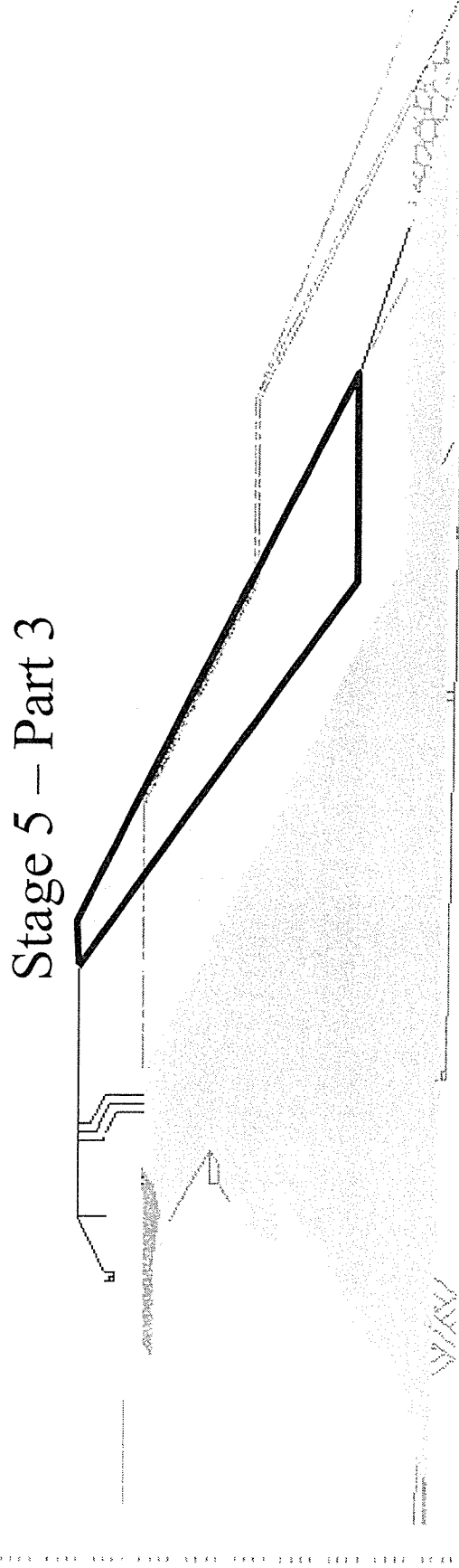

# Tailings Storage Facility

## ● Main Embankment X-section

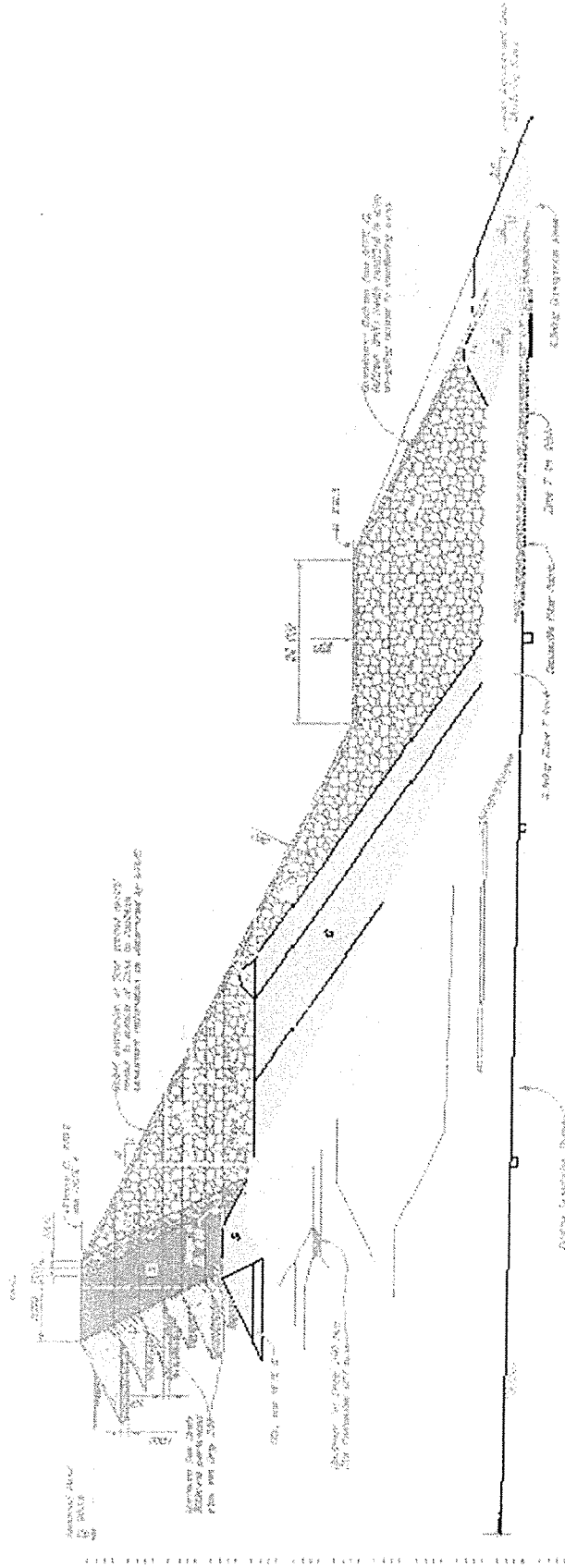



# Tailings Storage Facility

● South Embankment X-section:

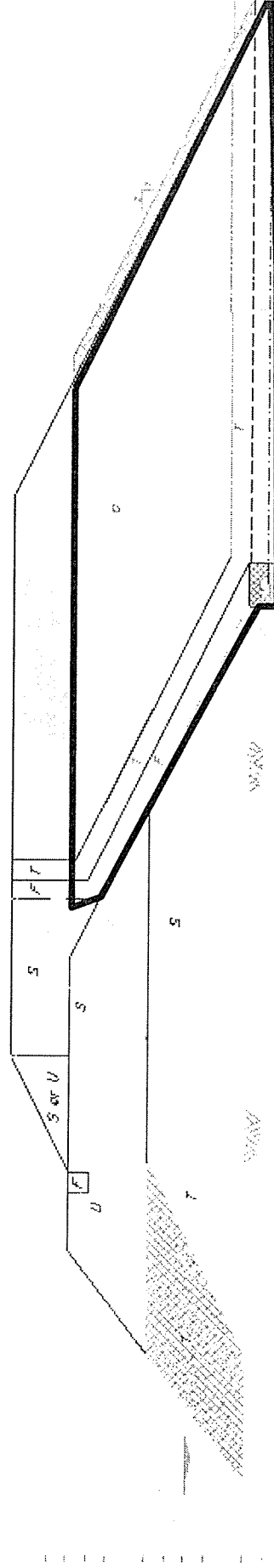
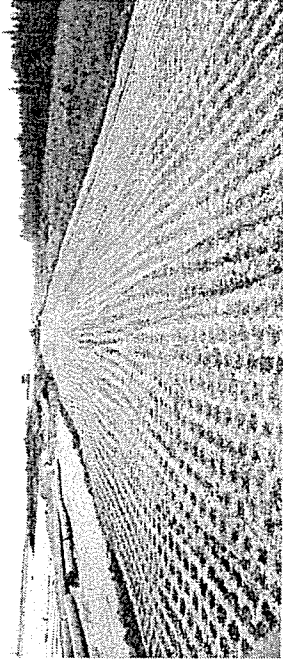

# Tailings Storage Facility

- ◆ South Embankment X-section:

Stage 5 – Part 2

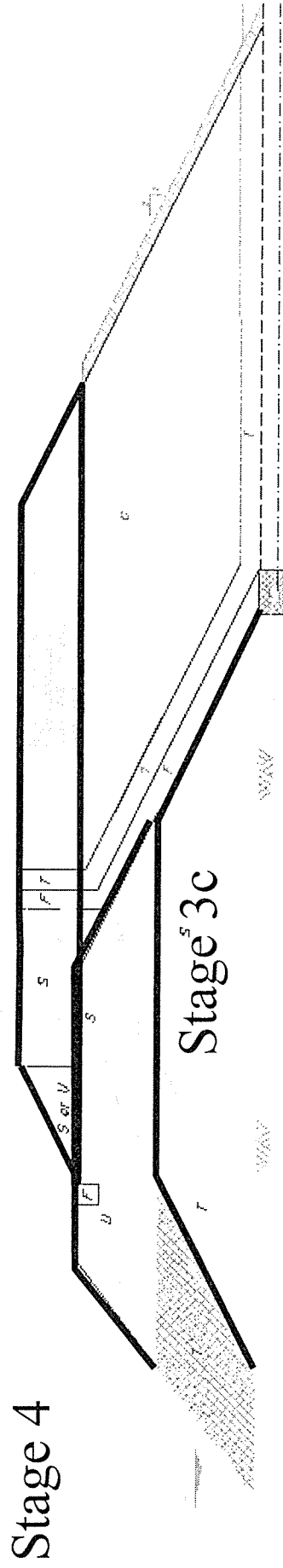

# TSF – Ultimate Design

## ● Draft South Embankment X-section

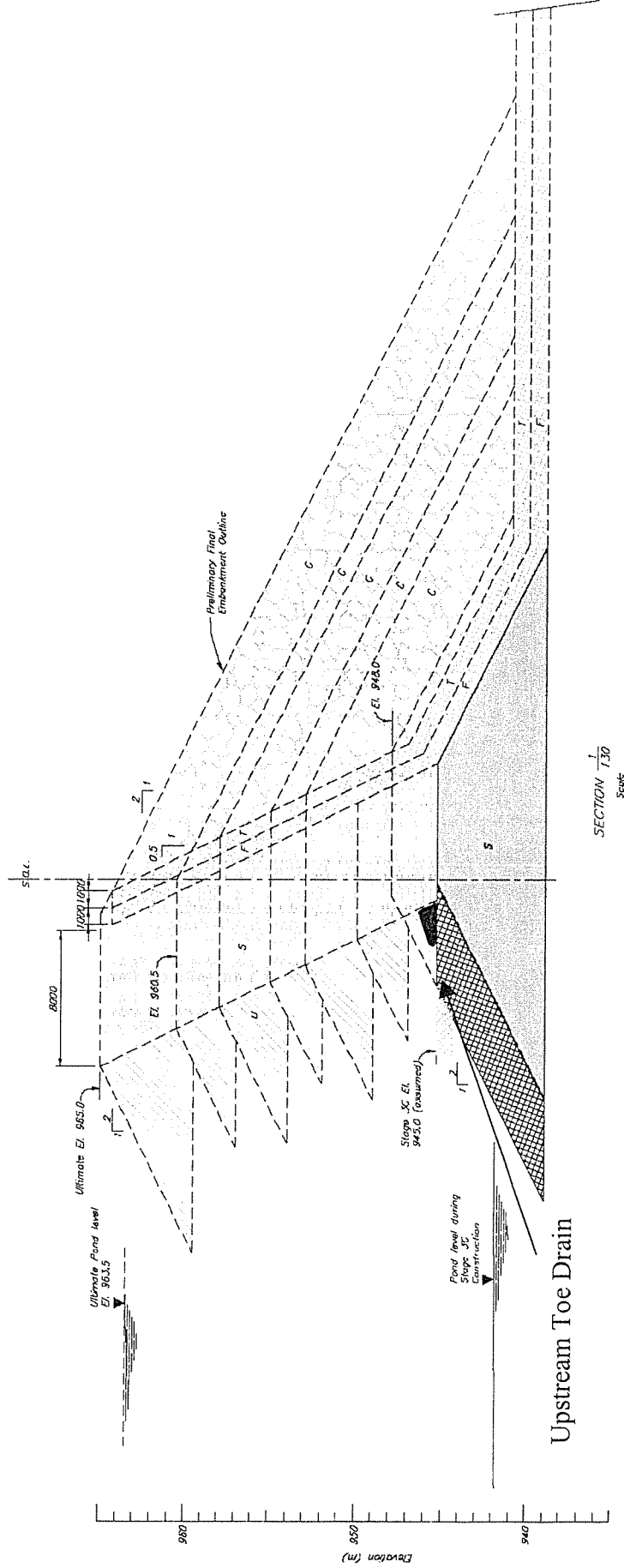

ID	Task Name	Duration	Start	Finish	January	February	March	April	May	June	July	August	September	October	November	December
1	Re-install Fill Barrow	5 days	Wed 02/01/06	Tue 02/07/06												
2	Complete Stage 4 to E1 End (Zone S and Zone U)	30 days	Wed 02/01/06	Tue 02/14/06												
3	Begin Linear Investigation between ME and SE	2 days	Wed 02/01/06	Thu 02/02/06												
4	Complete Basin Liner (if required)	5 days	Wed 02/08/06	Tue 02/14/06												
5	Investigate deep at PE at 3240G - Extend US to draw pipeline to perimeter	5 days	Wed 02/01/06	Tue 02/07/06												
6	Relocate Phosphorus Lines	4 days	Wed 02/01/06	Mon 02/06/06												
7																
8																
9																
10																
11	<b>Main Embankment</b>	145 days	Wed 02/01/06	Tue 08/22/06												
12	Extend Head Road to ME	10 days	Wed 02/01/06	Tue 02/14/06												
13	Rebar/Commission ME Storage Pond Recycle Materials to TSF	5 days	Wed 02/01/06	Tue 02/07/06												
14	Place Zone C on ME to FL 944 (230,000 tons)	95 days	Wed 02/15/06	Tue 05/22/06												
15	Install final Pond Inclinometers	10 days	Wed 02/15/06	Tue 02/21/06												
16	Source Process and Suitable Filter Sand Material - Resources Confirmed	20 days	Mon 02/13/06	Fr 02/24/06												
17	Place Zones F, T, S and C on ME to 951	40 days	Wed 02/22/06	Tue 04/04/06												
18	<b>Perimeter Embankment</b>	201 days	Wed 02/08/06	Wed 11/15/06												
19	Install US Ice Drain at PE	20 days	Wed 02/22/06	Tue 04/18/06												
20	Rebar/Commission PE Storage Pond Recycle Materials to TSF	5 days	Wed 02/08/06	Tue 02/14/06												
21	Place Zone C on PE to 314	81 days	Wed 02/22/06	Wed 04/26/06												
22	Place Zones F, T, S and C on PE to 951	20 days	Mon 02/13/06	Fr 02/24/06												
23																
24	<b>South Embankment</b>	78 days	Mon 02/27/06	Wed 12/06/06												
25	Improve SE Access Road	10 days	Mon 02/27/06	Fr 03/03/06												
26	Place Four (4) 10' x 10' Foundation Drains	5 days	Mon 03/06/06	Fr 03/10/06												
27	Place Zone C, F, T on SE to 318	20 days	Thu 03/02/06	Wed 03/15/06												
28	Place Zone S, T, F, U and C to 951 on SE	15 days	Thu 03/16/06	Wed 03/22/06												
29																
30	Develop and implement a tailings disposition plan which allows for beach draw	20 days	Mon 03/06/06	Fr 03/17/06												
31	Place Zone C on ME, PE and SF to 951 - full width	20 days	Thu 02/23/06	Wed 03/08/06												

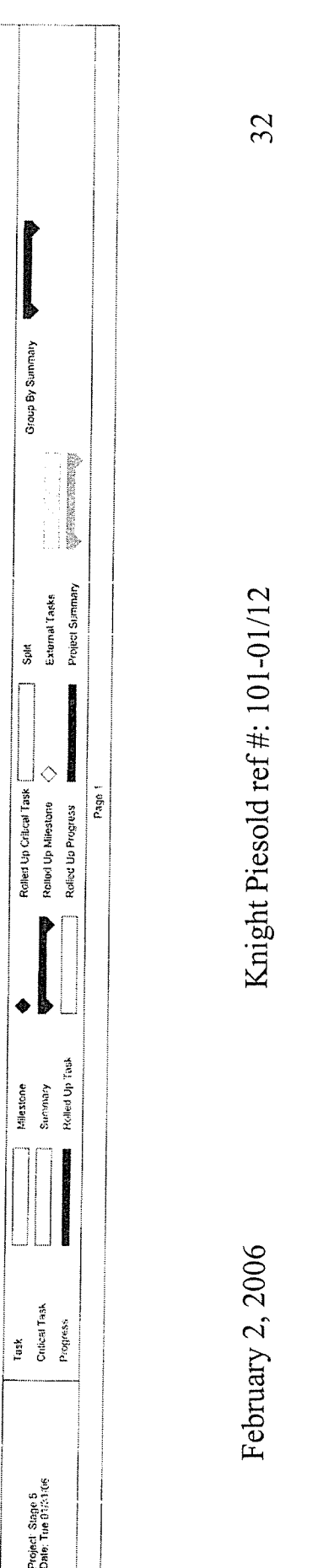

Project: Stage 5  
Date: Tue 02/14/06

Task: Critical Task  
Progress:

Milestone Summary:

Relied Up Task:

Relied Up Milestone:

Relied Up Progress:

Roll Up Critical Task:

Roll Up External Task:

Roll Up Project Summary:

Group By Summary:



# 2006 Checklist

## February

### General Items

- Re-establish till borrow
- Basin liner investigation
- Place till in basin if necessary
- Begin completing Stage 4 to El. 948m – Zone S and Zone U (Begin Feb 8, 2006)
- Investigate seep at PE (32+00)
- Extend U/S toe drain pipeline at PE (32+00)
- Relocate piezometer leads @ ME, PE and SE
- Install and read inclinometers



# 2006 Checklist

## February

### Main Embankment

- Extend haul road to ME and place Zone FT or filter fabric
- Relocate/decommission ME SCP pipeline
- Begin placing Zone C to El. 944m – 230,000tpm (Start Feb 15, 2006)

### Perimeter Embankment

- Relocate/decommission PE SCP pipeline



# 2006 Checklist

## March

### General Items

- Complete Stage 4 to El. 948m – Zone S and Zone U
- Complete Stage 5 design report

### Main Embankment

- Continue placing Zone C to El. 944m – 230,000tpm (completion in June)

### Perimeter Embankment

- Begin installing U/S toe drain (complete in April)



# 2006 Checklist

April

General Items

- Submit Stage 5 design report to MEM (April 1, 2006)

Main Embankment

- Continue placing Zone C to El. 944m – 230,000tpm (completion in June)

Perimeter Embankment

- Complete installation of U/S toe drain (complete this month)





# 2006 Checklist

## May

### Main Embankment

- Continue placing Zone C to El. 944m – 230,000t/m (completion in June)
- Source/process Zone F and stockpile



# 2006 Checklist

## June

### General Items

- Receive Stage 5 permit approval from MEM ( June 1, 2006)
- Dam safety review

### Main Embankment

- Complete placing Zone C to El. 944m – 230,000tpm (completion this month)
- Begin placing Zones F, T, S and C to El. 951m

### Perimeter Embankment

- Begin placing Zone C to El. 944m – 230,000tpm (completion in September)



# 2006 Checklist

July

Main Embankment

- Continue placing Zones F, T, S and C to El. 951m

Perimeter Embankment

- Continue placing Zone C to El. 944m (230,000tpm completion in September)



# 2006 Checklist

## August

### Main Embankment

- Complete placing Zones F, T, S and C to El. 951m

### Perimeter Embankment

- Continue placing Zone C to El. 944m (230,000tpm completion in September)

### South Embankment

- Improve South East access road



# 2006 Checklist

## September

### Perimeter Embankment

- Complete placing Zone C to El. 944m (230,000tpm completion in November)
- Begin placing Zones F, T, S and C to El. 951m

### South Embankment

- Prepare foundation
- Install foundation drains
- Begin placing Zone C, F and T to El. 948m



# 2006 Checklist

## October

### Perimeter Embankment

- Continue placing Zone C to El. 944m (230,000tpm completion in November)

### South Embankment

- Complete placing Zones C, F, and T to El. 948m



# 2006 Checklist

## November

### Perimeter Embankment

- Complete placing Zones F, C, T and S to El. 951m

### South Embankment

- Begin placing Zone F, C, U, T and S to El. 951m



# 2006 Checklist

## December

### All Embankments

- Place Zone C to El. 951m for final slope angle of 2:1
- Develop tailings deposition plan for TSF

### South Embankment

- Complete placing Zone F, C, U, T and S to El. 951m



# TSF – Ultimate Design

## Design Criteria

<b>Design Operation Life</b>	7 years
<b>Hazard rating:</b>	HIGH by CDA Consequence Classification HIGH by CDA Consequence Classification
<b>Design Earthquakes:</b>	1 in 475 year event ( $M = 6.5, A_{max} = 0.037 \text{ g}$ ) 50% of the 1 in 2000 year event or MCE ( $M = 6.5, A_{max} = 0.065 \text{ g}$ ) 1 in 2000 year event
<b>Embankment Crest Width: (Final Width)</b>	8 m
<b>Design Tonnage</b>	7,300,000 tpy (20,000 tpd)
<b>Freeboard:</b>	24 hour PMP event (679,000 m <sup>3</sup> ) plus 1.0 m wave run Sufficient to provide routing of PMF plus wave run-up
<b>Storage Capacity:</b>	76,000,000 tonnes

# TSF – Monitoring

## Inclinometer readings

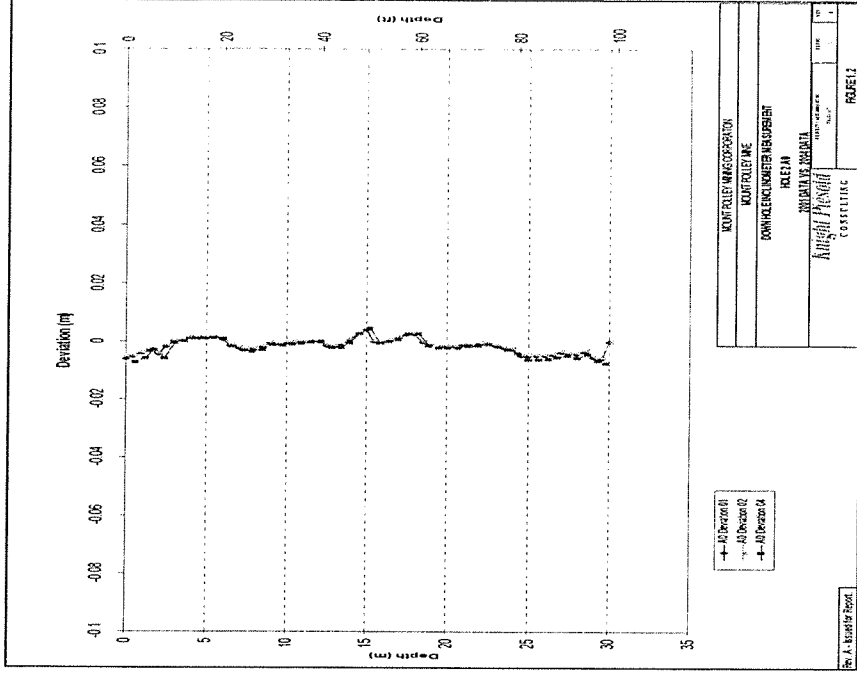
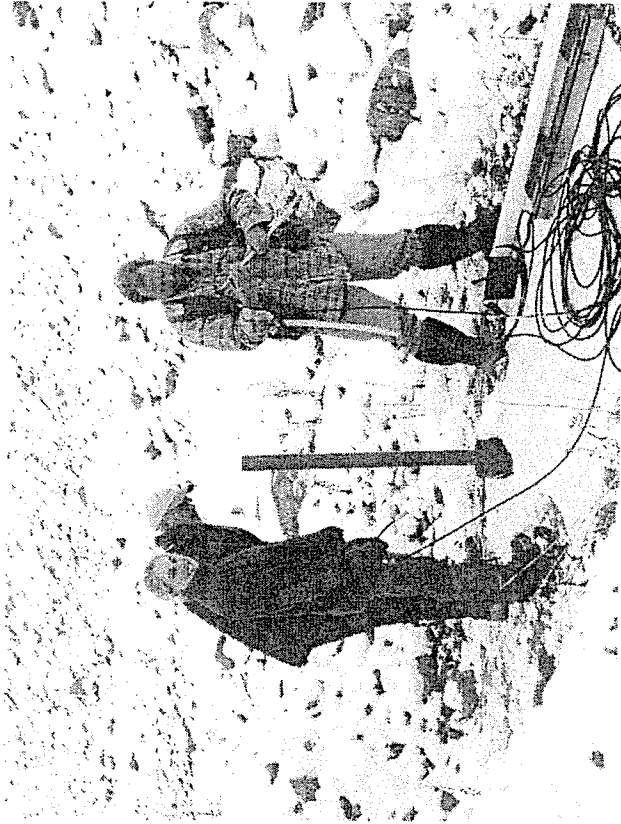

Typical inclinometer reading

# TSF - Monitoring

## Typical piezometer readings (to date)

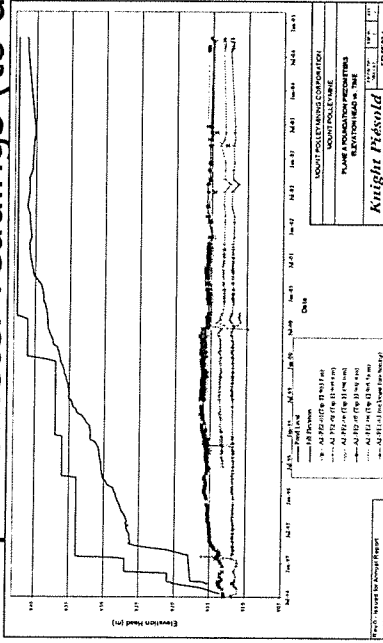
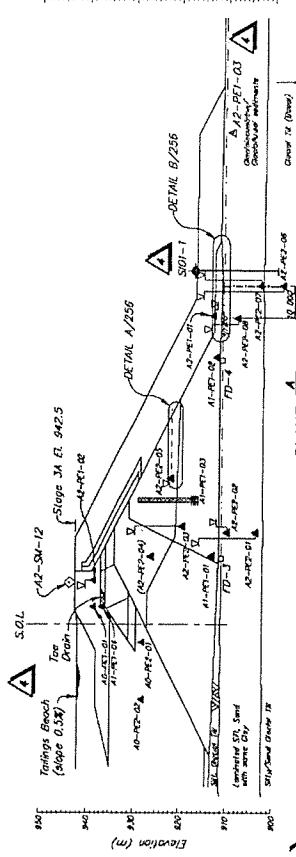

Plane A foundation piezometer

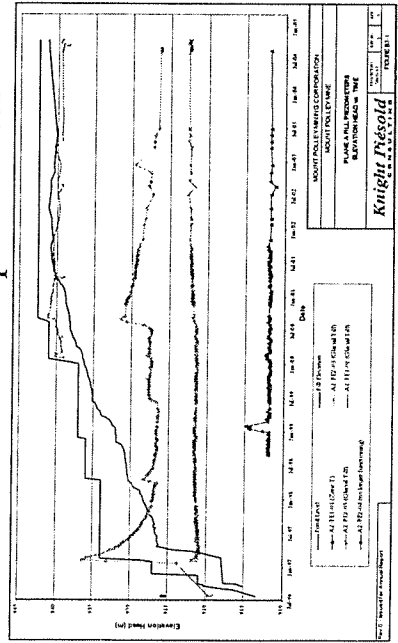

Plane A fill piezometer

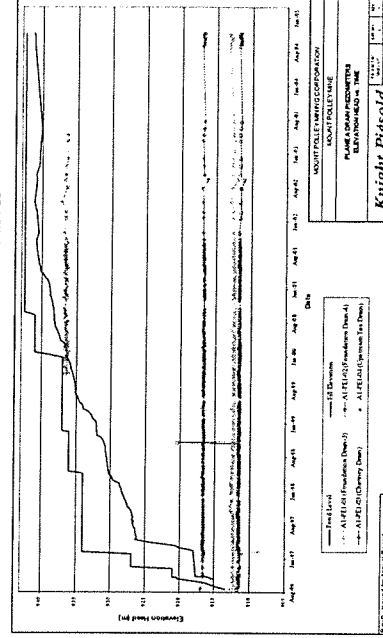

Plane A drain piezometer

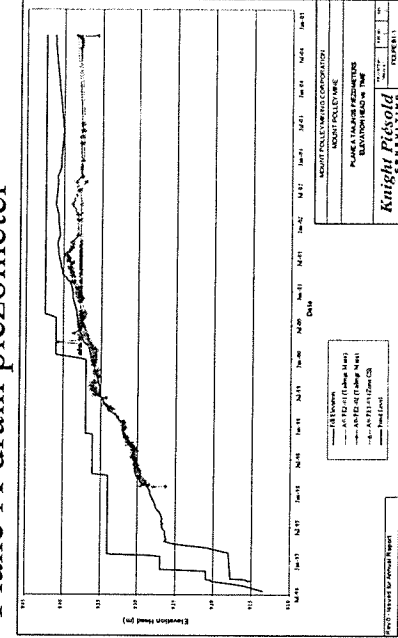

Plane A tailings piezometer

February 2, 2006

Knight Piesold ref #: 101-01/12

# TSF – Monitoring

## ● Drain Flow Readings

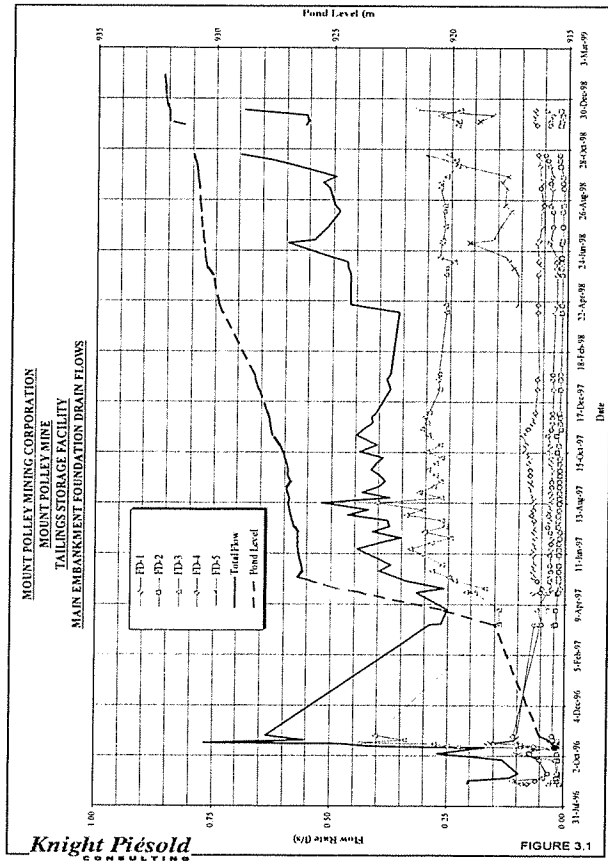

Typical foundation drain flow readings

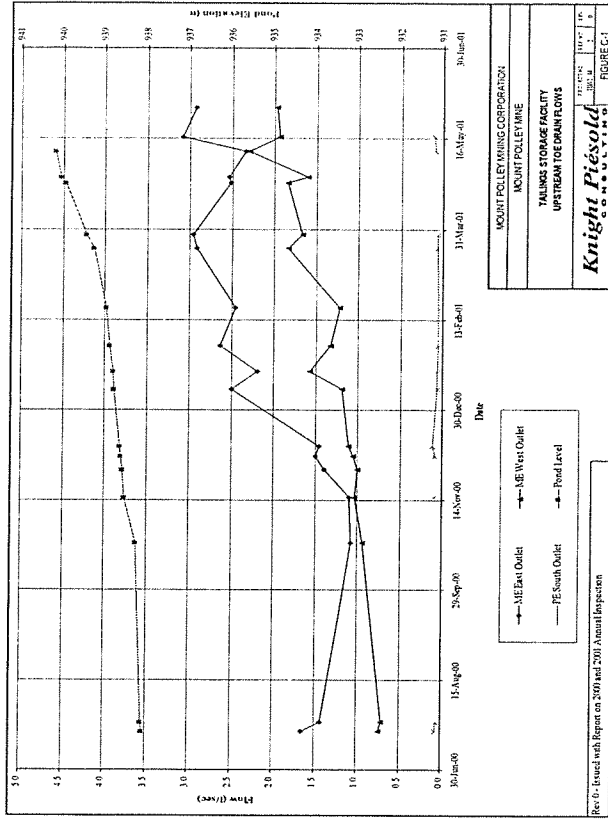

Typical upstream toe drain flow readings





# **TSF - Operations**

P

P

P

P

P

# TSF – Tailings Deposition

- Water Management
- Tailings Deposition Strategy
- ⊗ = Pump

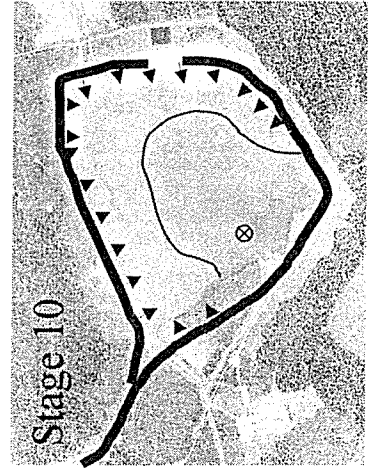
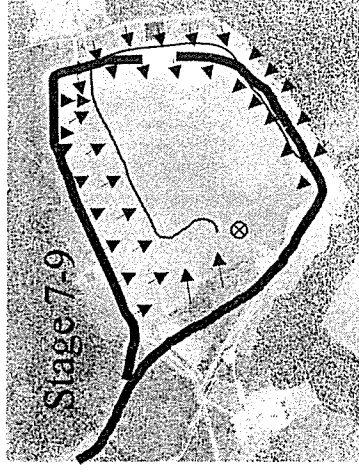
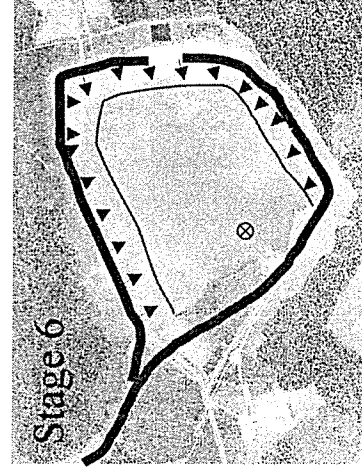
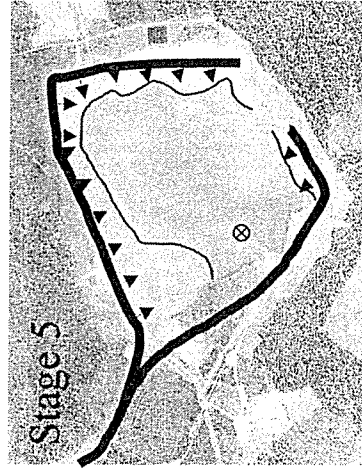

- Seepage from Main Embankment Seepage Recycle Pond pumped into tailings pond
- Tailings supernatant pond volume increases over life of mine
- Freeboard maintained for containment of PMP runoff plus 1m for wave run-up

# TSF – Closure

- Proposed Closure Plan
  - From Report on Cycloned sand Construction of Stage 3 and On-going Stages of The Tailings Storage Facility, 1999

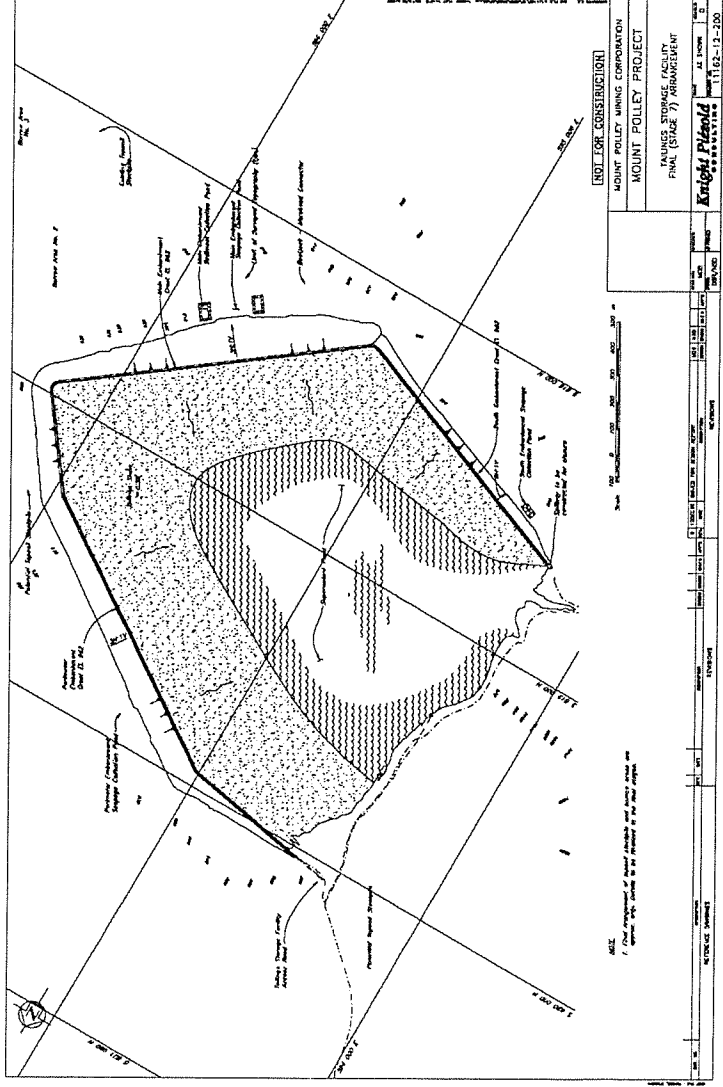



# Questions on TSF?

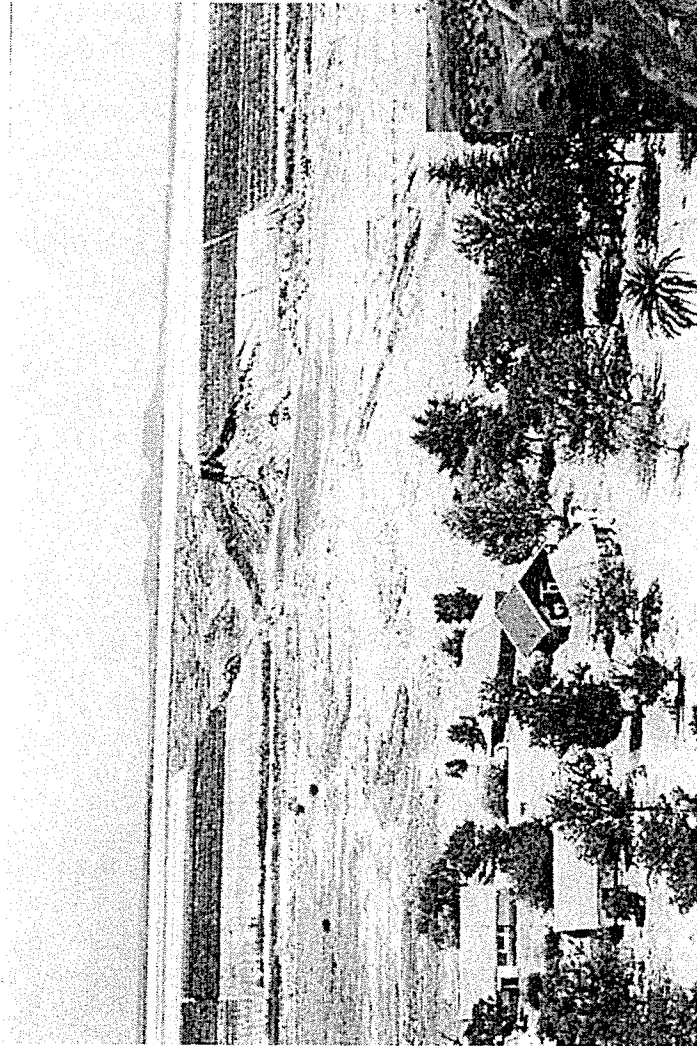

# Wight Pit Dewatering

- ◆ Waste rock dump and haul road.

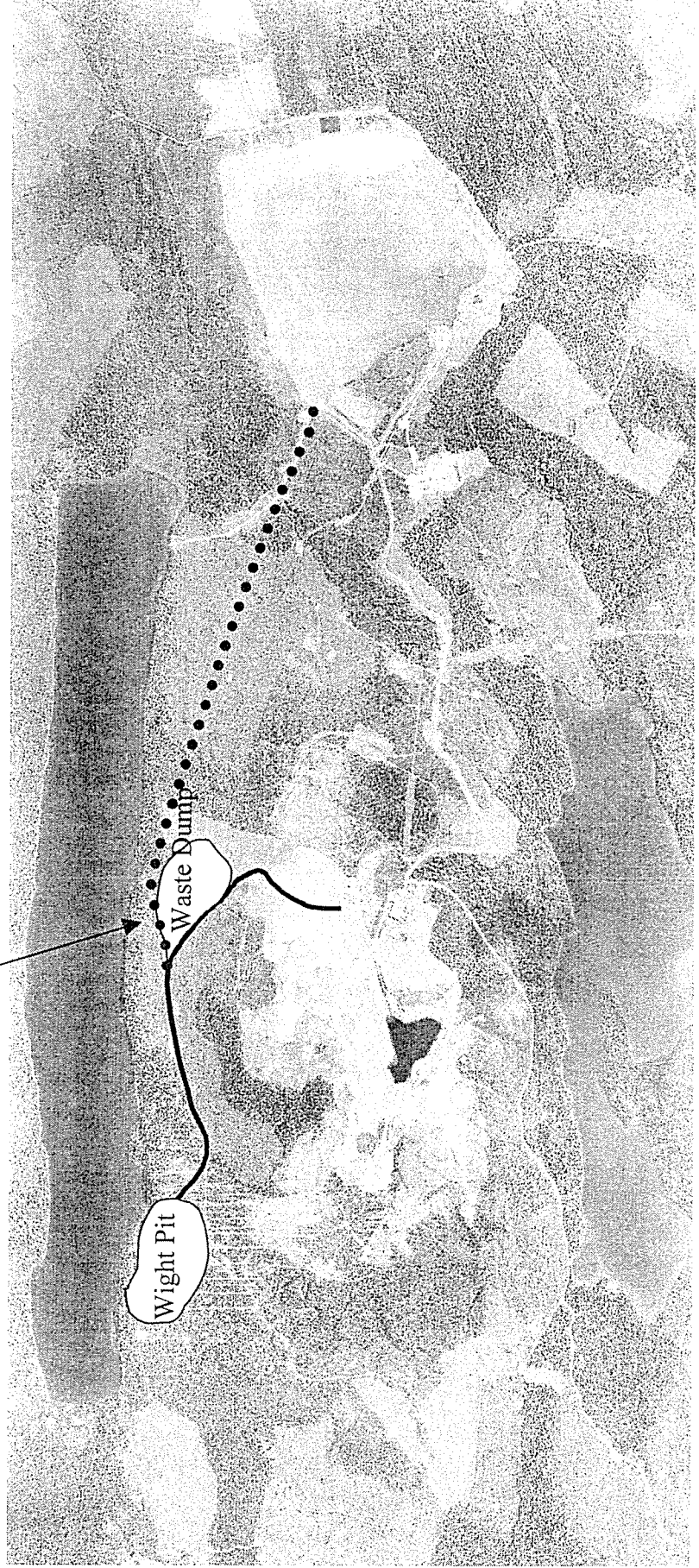

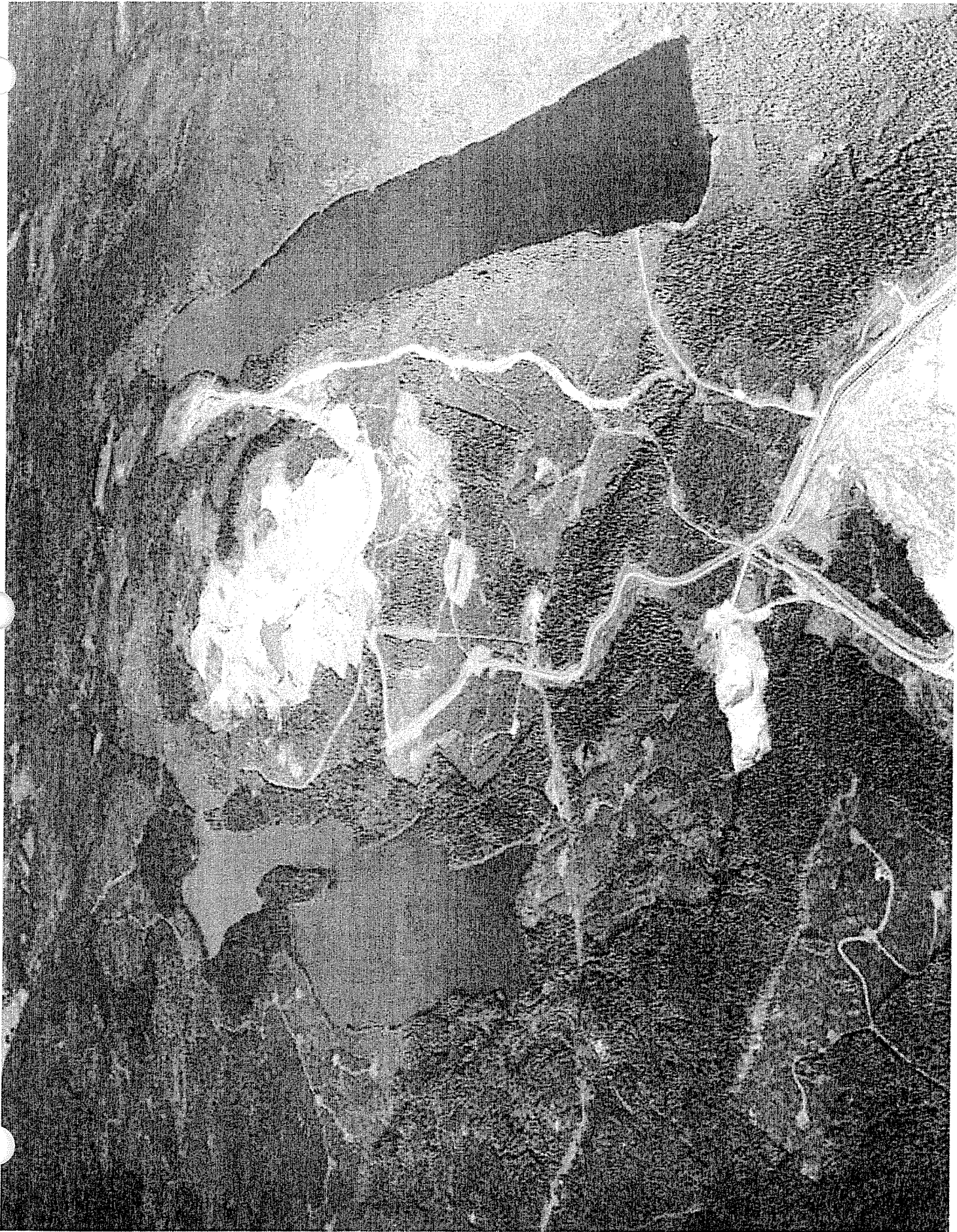

# Wight Pit Dewatering

## INITIAL PIPEWORK LAYOUT

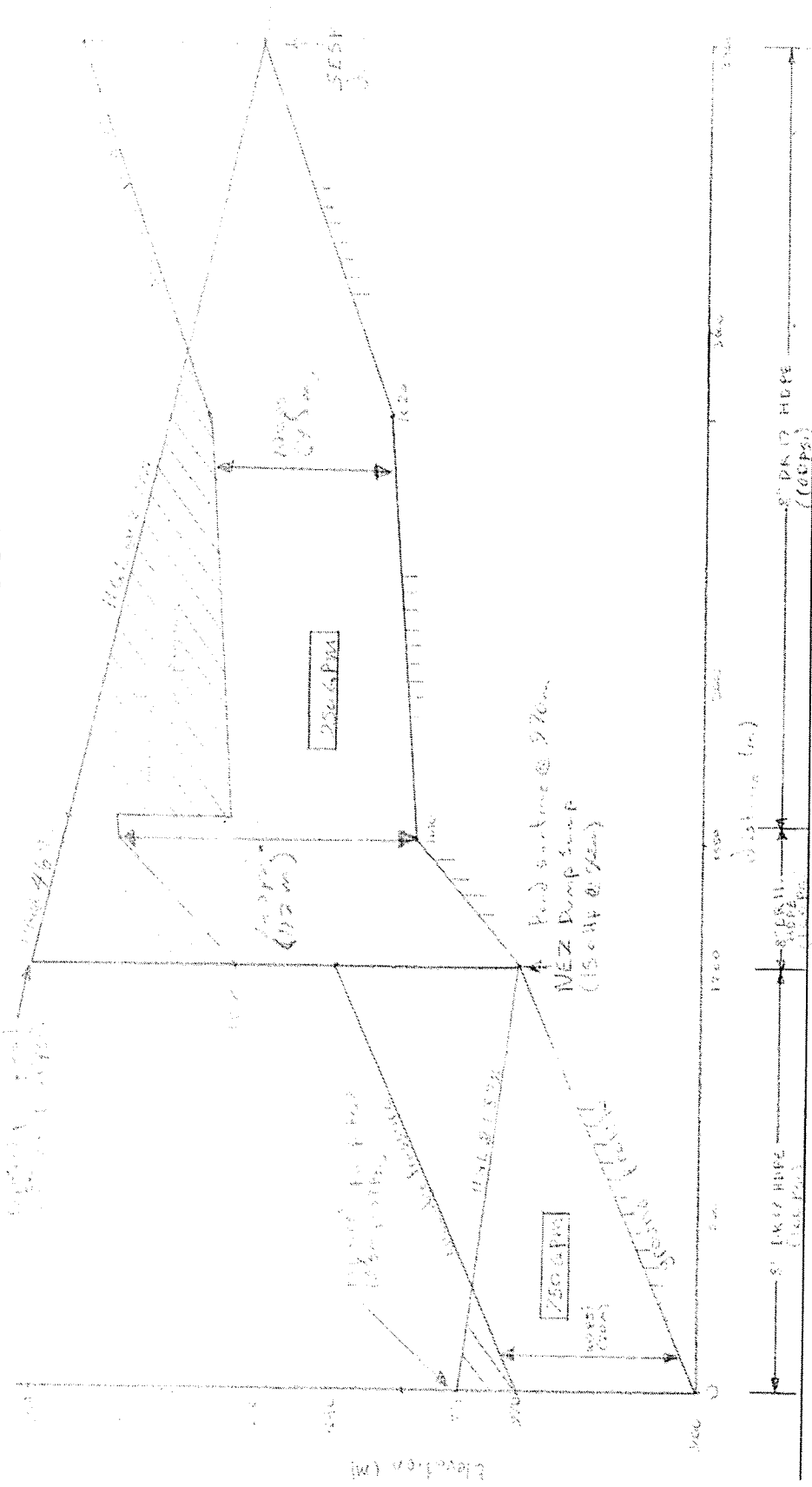

# Wight Pit Dewatering

## REVISED PIPEWORK LAYOUT

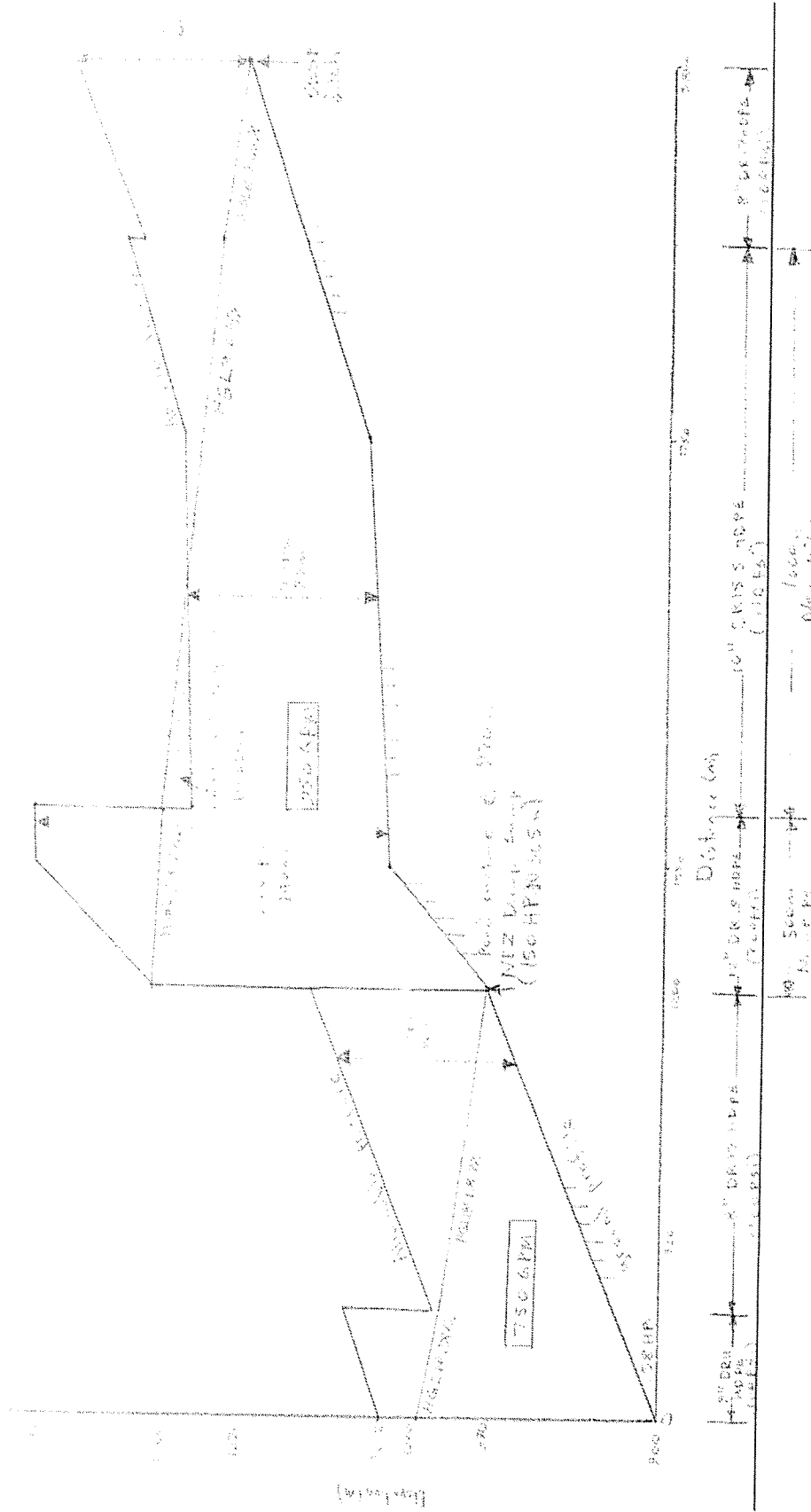

February 2, 2006

Knight Piesold ref #: 101-01/12



# *Wight Pit Dewatering*

- Design flows based on peak month.
- Existing 8" DR17 and DR11 can be used between pit surface and sump and sediment pond (750GPM)
- Pump head between pit and sediment pond can be provided by an existing 58 HP pump.
- New large diameter, higher pressure pipe (12" DR9, 10" DR155 or similar) required between sediment pond and ditch.
- Pumping at sediment pond requires 150HP for 950 GPM design flow.
- At lower flows pumps will cycle on/off.
- Sufficient storage is required to reduce cycle frequency.