

MINISTRY OF
ENERGY AND MINES
REC'D JUN 23 2006



**MOUNT POLLEY MINING CORPORATION
MOUNT POLLEY MINE**

**STAGE 5 DESIGN OF THE
TAILINGS STORAGE FACILITY
(REF. NO. VA101-01/12-1)**

| Rev. No. | Revision | Date | Approved |
|----------|-------------------|---------------|----------|
| 0 | Issued for Report | June 12, 2006 | KIB |
| | | | |
| | | | |
| | | | |

MP00027

Knight Piésold Ltd.

Suite 1400
750 West Pender Street
Vancouver, British Columbia
Canada V6C 2T8

Telephone: (604) 685-0543
Facsimile: (604) 685-0147
E-mail: kpl@knightpiesold.bc.ca



CRIT 4147

**MOUNT POLLEY MINING CORPORATION
MOUNT POLLEY MINE**

**STAGE 5 DESIGN OF THE
TAILINGS STORAGE FACILITY
(REF. NO. VA101-01/12-1)**

EXECUTIVE SUMMARY

The Mount Polley gold and copper mine is owned by Mount Polley Mining Corporation (MPMC). It is located 56 kilometres northeast of Williams Lake, in central British Columbia. Mount Polley mine re-opened in the March 2005 after managing the facilities for Care and Maintenance activities since October 2001. MPMC is currently mining the Bell and Wight Pits with the tailings material being deposited as slurry into the Tailings Storage Facility (TSF). Process water is collected and recycled back to the mill for recycle in the milling process.

This report provides supporting documentation to allow for MPMC to permit the staged expansion of the TSF embankments from the existing permitted elevation of 948 m for the Stage 4 expansion to a new Stage 5 elevation of 951 m. The Stage 5 design of the TSF is consistent with the general design and construction methodology of the TSF to its ultimate elevation of 965 m and consists of adding 3 m to the current crest elevation of the embankments using the modified centreline construction method. This elevation will provide sufficient storage in the TSF for approximately one year of operations while maintaining the required water storage and freeboard requirements. Details on the ultimate design of the TSF were issued to the Ministry of Energy and Mines (MEM) in March 2005 (Knight Piésold Report "Design of the Tailings Storage Facility to Ultimate Elevation", Ref. No. VA101-1/8-1). MPMC requested at that time that MEM consider permitting the TSF to its ultimate elevation of 965 m, assuming that there would be no significant changes in the design or construction methodology of the TSF. Significant changes in the design or construction methodology of the TSF would require MPMC to submit the revised design for permit approval prior to expanding the TSF embankments. Detailed design reports, construction drawings, technical specifications, and construction reports would be prepared for each stage of the TSF expansions by a suitably qualified Professional Engineer.

A total of 56 vibrating wire piezometers have been installed in the tailings, foundation, embankment fill materials and drains to date. Additional vibrating wire piezometers will be installed during the Stage 5 expansion of the TSF. The inclinometers installed downstream of the Main Embankment through the lacustrine unit will be extended through the shell zone as it is constructed. Survey monuments will be installed on the completed Stage 5 crest.

Embankment drainage provisions have been incorporated into the design of the TSF to facilitate drainage of the tailings mass, dewater the foundation soils, and to control the phreatic surface within the embankments. The components of the drainage systems consist of foundation drains, chimney drains, longitudinal drains, outlet drains, and upstream toe drains. The upstream toe drains are effective in lowering the phreatic surface, which increases embankment stability and

seepage control. The upstream toe drains also remove a certain amount of filtered water from the impoundment, and it may be possible to establish water discharge points below the seepage collection ponds if water quality objectives are met. An upstream toe drain already exists at the Main Embankment and one will be installed at the Perimeter Embankments during Stage 5. An upstream toe drain will be installed at the South Embankment during a future staged expansion.

Foundation drains, along with a sump and seepage recycle pumpback system will be installed at the South Embankment prior to placement of the downstream shell zone material.

The TSF is required to have sufficient live storage capacity for containment of runoff from the 24-hour PMP volume of 679,000 m³ at all times, which would result in an incremental rise in the tailings pond level of approximately 0.39 m. The 24-hour PMP allowance is in addition to regular inflows from other precipitation runoff, including the spring freshet. The TSF design also incorporates an additional allowance of 1 meter of freeboard for wave run-up.

Stability analyses were completed for static and seismic conditions and indicate that the TSF embankments are stable under static and seismic conditions and that deformations initiated by earthquake loading will be insignificant.

Knight Piésold will provide the construction drawings, technical specifications, and QA/QC for Stage 5 expansion of the TSF. Knight Piésold will also issue a construction report following the Stage 5 construction program. A Dam Safety Review is scheduled for the summer of 2006.

**MOUNT POLLEY MINING CORPORATION
MOUNT POLLEY MINE**

**STAGE 5 DESIGN OF THE
TAILINGS STORAGE FACILITY
(REF. NO. VA101-01/12-1)**

TABLE OF CONTENTS

| | PAGE |
|---|-------------|
| EXECUTIVE SUMMARY | i |
| TABLE OF CONTENTS..... | i |
| SECTION 1.0 - INTRODUCTION | 1 |
| 1.1 PROJECT DESCRIPTION | 1 |
| 1.2 SCOPE OF REPORT | 1 |
| 1.3 REFERENCES | 2 |
| SECTION 2.0 - TAILINGS STORAGE FACILITY | 3 |
| 2.1 GENERAL | 3 |
| 2.2 HAZARD CLASSIFICATION | 4 |
| 2.3 FOUNDATION CONDITIONS | 4 |
| 2.4 TAILINGS AND RECLAIM PIPELINES..... | 5 |
| 2.5 EMBANKMENT DRAINAGE PROVISIONS..... | 5 |
| 2.6 SEEPAGE COLLECTION PONDS | 7 |
| 2.7 INSTRUMENTATION..... | 7 |
| 2.8 WATER MANAGEMENT | 8 |
| SECTION 3.0 - STAGE 5 TAILINGS STORAGE FACILITY DESIGN..... | 9 |
| 3.1 GENERAL | 9 |
| 3.2 STABILITY ANALYSIS..... | 10 |
| SECTION 4.0 - CERTIFICATION | 11 |

TABLES

| | |
|-----------------|---|
| Table 3.1 Rev 0 | Stage 5 Design Basis and Operating Criteria |
| Table 3.2 Rev 0 | Stability Analyses Summary |

FIGURES

| | |
|------------------|--|
| Figure 1.1 Rev 0 | Project Location and Access Plan |
| Figure 1.2 Rev 0 | Aerial Photograph of Mount Polley Mine – Viewing North |
| Figure 1.3 Rev 0 | Aerial Photograph of Mount Polley Mine – Viewing South |

Figure 2.1 Rev 0 Tailings Depositional Strategy - Stage 5 to Stage 10
Figure 3.1 Rev 0 Filling Schedule

DRAWINGS

| | |
|----------------------------|---|
| Drawing 101-1/12-100 Rev 0 | Overall Site Plan |
| Drawing 101-1/12-102 Rev 0 | TSF- General Arrangement – Stage 5 Crest Elevation |
| Drawing 101-1/12-104 Rev 0 | TSF - Stage 5 Tailings Embankment - Material Specifications |
| Drawing 101-1/12-210 Rev 0 | TSF - Stage 5 Main Embankment - Plan |
| Drawing 101-1/12-215 Rev 0 | TSF - Stage 5 Main Embankment - Section |
| Drawing 101-1/12-216 Rev 0 | TSF - Stage 5 Main Embankment – Detail |
| Drawing 101-1/12-220 Rev 0 | TSF - Stage 5 Perimeter Embankment - Plan |
| Drawing 101-1/12-225 Rev 0 | TSF - Stage 5 Perimeter Embankment – Section |
| Drawing 101-1/12-226 Rev 0 | TSF - Stage 5 Perimeter Embankment – Detail |
| Drawing 101-1/12-230 Rev 0 | TSF - Stage 5 South Embankment - Plan |
| Drawing 101-1/12-235 Rev 0 | TSF - Stage 5 South Embankment – Sections |
| Drawing 101-1/12-236 Rev 0 | TSF – Stage 5 South Embankment - Longitudinal and Foundation Drain – Sections and Details |
| Drawing 101-1/12-240 Rev 0 | TSF – Stage 5 Perimeter Embankment – Upstream Toe Drain – Sections and Details |
| Drawing 101-1/12-336 Rev 0 | TSF – Existing Instrumentation - Main Embankment - Plan |
| Drawing 101-1/12-338 Rev 0 | TSF - Existing Instrumentation - Perimeter Embankment - Plan |
| Drawing 101-1/12-340 Rev 0 | TSF - Existing Instrumentation - South Embankment - Plan |
| Drawing 101-1/12-346 Rev 0 | TSF - Stage 5 - Instrumentation - Main Embankment – Planes A and B |
| Drawing 101-1/12-347 Rev 0 | TSF - Stage 5 - Instrumentation - Main Embankment – Planes C and E |
| Drawing 101-1/12-348 Rev 0 | TSF - Stage 5 - Instrumentation - Perimeter Embankment – Planes D, G and H |
| Drawing 101-1/12-349 Rev 0 | TSF - Stage 5 - Instrumentation – South Embankment - Planes F and I |

APPENDICES

APPENDIX A Technical Paper on “Modified Centreline Construction of Tailings Embankments”

**MOUNT POLLEY MINING CORPORATION
MOUNT POLLEY MINE**

**STAGE 5 DESIGN OF THE
TAILINGS STORAGE FACILITY
(REF. NO. VA101-01/12-1)**

SECTION 1.0 - INTRODUCTION

1.1 PROJECT DESCRIPTION

The Mount Polley gold and copper mine is owned by Mount Polley Mining Corporation (MPMC). It is located 56 kilometres northeast of Williams Lake, in central British Columbia. The project site is accessible by paved road from Williams Lake to Morehead Lake and then by gravel road for the final 12 km. The location of Mount Polley Mine is shown on Figure 1.1. Mount Polley Mine started production in 1997 and had milled approximately 27.5 million tonnes of ore prior to temporarily suspending operations from October 2001 to March 2005. MPMC is currently mining the Bell and Wight Pits with the tailings material being deposited as slurry into the Tailings Storage Facility (TSF). Process water is collected and recycled back to the mill for recycle in the milling process. The average throughput for 2005 was approximately 15,000 tpd. Aerial photographs of Mount Polley Mine obtained in October 2005 are shown on Figures 1.2 and 1.3. The overall Mount Polley Mine site plan is shown on Drawing 100. The general arrangement of the TSF is shown on Drawing 102.

1.2 SCOPE OF REPORT

The Tailings Storage Facility at Mount Polley Mine has an ultimate elevation of 965 m. This elevation will provide sufficient storage in the TSF for approximately 85 million tonnes of tailings while maintaining the required water storage and freeboard requirements. Details of the design of the TSF to an ultimate elevation of 965 m were issued in the Knight Piésold Report "Design of the Tailings Storage Facility to Ultimate Elevation", Ref. No. VA101-1/8-1, March 14, 2005.

MPMC is currently in the process of raising the TSF embankments to the currently permitted elevation of 948 m. Knight Piésold provided the design, technical specifications, and QA/QC for the Stage 4 expansion of the TSF. The scope of this report is to provide supporting documentation to allow for MPMC to obtain permits for the Stage 5 expansion of the TSF embankments to an elevation of 951 m. This elevation will provide sufficient storage in the TSF for approximately one year of operations while maintaining the required water storage and freeboard requirements. The Stage 5 design of the TSF is consistent with the design and construction methodology of the TSF to its ultimate elevation of 965 m, and consists of adding 3 m to the current crest elevation of the embankments using the modified centreline construction method. The drawings contained within this report are for permitting support and will be updated prior to being "Issued for Construction".

1.3 REFERENCES

This report references the following documents, which provide key supplementary information:

Knight Piésold Report “Design of the Tailings Storage Facility to Ultimate Elevation”, Ref. No. VA101-1/8-1, March 14, 2005.

Knight Piésold Report “Updated Design Report”, Ref. No. 1627/2, June 6, 1997.

Knight Piésold Report “Report on 2005 Annual Inspection”, Ref. No. VA101-1/11-1, May 3, 2006.

MAJM Corporation Ltd., Report to Imperial Metals Corporation, “Geotechnical Review, Drainage Aspects Main Embankment Dam, Tailings Storage Facility Report,” March 1997.

SECTION 2.0 - TAILINGS STORAGE FACILITY

2.1 GENERAL

The principal objectives of the TSF are to provide secure containment for tailings solids and to ensure that the regional groundwater and surface water flows are not adversely affected during or after mining operations. The design and operation of the TSF is integrated with the overall water management objectives for the entire mine development, in that surface runoff from disturbed catchment areas is controlled, collected and contained on site. An additional requirement for the TSF is to allow effective reclamation of the tailings impoundment and associated disturbed areas at closure to meet land use objectives.

The main components of the TSF are as follows:

- The TSF embankments incorporate the following zones and materials:
 - Zone S - Core zone - fine grained glacial till.
 - Zone CS - Upstream shell - cycloned or spigotted tailings sand.
 - Zone B - Embankment shell zones - fine grained glacial till.
 - Zone F - Filter, drainage zones, and chimney drain - processed sand and gravel.
 - Zone T - Transition filter zone - select well-graded fine-grained rockfill.
 - Zone C - Downstream shell zone – rockfill.
 - Zone U – Upstream shell zone – parameters vary depending on material availability.
- A low permeability basin liner (natural and constructed) covers the base of the entire facility, at a nominal depth of at least 2 m. The low permeability basin liner has proven to be effective in minimizing seepage from the TSF as there have been no indications of adverse water quality reporting to the groundwater monitoring wells.
- A foundation drain and pressure relief well system, located downstream of the Stage 1B Main Embankment. The foundation drain and pressure relief well system prevent the build-up of excess pore pressure in the foundation, and transfer groundwater and/or seepage to the collection ponds.
- Seepage collection ponds located downstream of the Main and Perimeter Embankments. These ponds were excavated in low permeability soils and store water collected from the embankment drains and from local runoff.
- Instrumentation in the tailings, earthfill embankments and embankment foundations. This includes vibrating wire piezometers, survey monuments, and slope inclinometers.
- A system of groundwater quality monitoring wells installed around the TSF.

The tailings embankments have been designed for staged expansion using the modified centreline construction method. A technical paper on the “Modified Centreline Construction of Tailings Embankments” is included in Appendix A.

2.2 HAZARD CLASSIFICATION

The classification of the TSF has been assessed using the Canadian Dam Association and the British Columbia Dam Safety Regulation guidelines. These guidelines look at the consequences of failure and consider life safety, economic and social losses, and environmental and cultural losses. The life safety category considers the potential for multiple loss of life after ascertaining the degree of development within the inundation area. The economic and social loss category considers damage to infrastructure, public and commercial facilities that are in and beyond the inundation area. This includes damage to railways, highways, powerlines, residences etc. The environmental and cultural loss considers damage to fish habitat at the regional, provincial, and national level, wildlife habitat, including water quality, and unique landscapes or sites of cultural significance.

The assessment indicates that the TSF has a "HIGH" hazard classification (or consequence category) based on the economic and social loss category. The classification for the life safety and environmental and cultural loss categories is "LOW", as there is low potential for multiple loss of life, the inundation area is typically undeveloped, and there is unlikely to be loss or significant deterioration of provincially or nationally important fish habitat. However, the ultimate TSF embankments will be up to 55 m high, and the estimated costs associated with repairing the damage, loss of service to the mine, and the potential economic impact on Imperial Metals, could exceed \$1,000,000, which places the TSF into the "HIGH" economic and social losses category under the British Columbia Dam Safety Regulation guidelines.

The classification of dams under the Canadian Dam Association and the British Columbia Dam Safety Regulation guidelines corresponds to consequences of failure and does not relate in any way to the likelihood of failure. The embankment has been designed to accommodate a maximum design earthquake (MDE) corresponding to 50% of the maximum credible earthquake (MCE) and the impoundment is sized to contain the probable maximum precipitation (PMP) storm event. The TSF at Mount Polley Mine is visually inspected daily by MPMC staff during operations, and the embankment instrumentation is monitored at regular intervals during operations with the frequency of monitoring increasing during the TSF expansion phases. The likelihood of dam failure is therefore extremely low.

2.3 FOUNDATION CONDITIONS

The tailings basin is generally blanketed by naturally occurring well-graded low permeability glacial till, which functions as an in-situ soil liner. However, a basin liner was constructed just upstream of the Main Embankment during Stage 1a to ensure that the basin liner had a minimum thickness of 2 m throughout the tailings basin. The constructed basin liner was tied into the Main Embankment core zone and the existing basin liner where the in-situ thickness exceeded 2 m.

The south ridge between the Main and South Embankments was investigated during the Stage 4 construction program to confirm the thickness of the basin liner in this area. The investigation found that the basin liner thickness was less than the required minimum thickness of 2 m near the crest of the ridge. A basin liner was constructed in this area during the Stage 4 construction

program to ensure that the basin liner had a minimum thickness of 2 m throughout this area and that it tied into the South Embankment core zone.

The foundation conditions at the Main Embankment consist of low permeability glacial till material at surface underlain by fluvial and lacustrine silts up to 20 m thick. The foundation conditions at the Perimeter Embankment consist of low permeability glacial till throughout that is generally in excess of 5 m thick. The foundation conditions at the South Embankment consist of a relatively thin, low permeability glacial till material overlying bedrock. Details of the site geological investigations can be found in the Knight Piésold Report "Updated Design Report", Ref. No. 1627/2, June 6, 1997.

Laboratory testwork on the foundation soils indicates that the materials have adequate shear strength to ensure foundation stability of the embankments. Artesian pressures exist at the base of the Main Embankment. Pressure relief wells have been installed previously at this location to depressurize the underlying glaciofluvial deposits. Ongoing monitoring has confirmed that design objectives are being met during on-going operations.

2.4 TAILINGS AND RECLAIM PIPELINES

The tailings pipeline comprises 7 km of HDPE pipe of varying diameters and pressure ratings and has a design flow of 20,000 tonnes/day at 35% solids by dry weight. The tailings pipeline has a single, movable discharge section, which allows for controlled deposition of tailings from an isolated section of the embankment to evenly distribute tailings from around the perimeter of the facility. Evenly discharging the tailings from around the facility optimizes the development of tailings beaches and keeps the supernatant pond clear of the embankments, thereby increasing seepage paths and limiting seepage loss from the facility. Beached tailings, when left to drain and consolidate, form the competent foundations needed for the modified centreline construction embankment raises. The optimized tailings beach development from Stages 5 through 10 is shown schematically on Figure 2.1. Tailings material was also being used during the Stage 4 construction program as Zone U material, which is located upstream of the core zone on the tailings beaches.

The reclaim pipeline system returns water from the TSF to the mill site for re-use in the process. The system comprises a pump barge, a reclaim pipeline and a reclaim booster pump station.

The tailings pipeline, reclaim system and tailings deposition within the TSF are reviewed annually as part of the annual inspection and as part of each design phase for the expansion of the TSF.

2.5 EMBANKMENT DRAINAGE PROVISIONS

Embankment drainage provisions have been incorporated into the design of the TSF to facilitate drainage of the tailings mass, dewater the foundation soils, and to control the phreatic surface within the embankments. The components of the drainage systems consist of foundation drains, chimney drains, longitudinal drains, outlet drains, and upstream toe drains. The conveyance pipework for all of the drains terminates in the drain monitoring sumps at the Main and Perimeter

Embankments where the drain flows and water quality are monitored. A drain monitoring sump will be installed at the South Embankment during the Stage 5 construction program. The drainage systems are reviewed as part of the annual inspection and as part of each design phase for the expansion of the TSF. The drainage provisions for the TSF are as follows:

Foundation Drains - A system of foundation drains was installed in the Main and Perimeter Embankment foundations to improve the foundation conditions and enhance the dewatering of near surface soils. Pressure relief wells and pressure relief trenches connected to the foundation drains were included to depressurize the underlying glaciofluvial deposits to enhance the stability of the embankment.

Chimney, Longitudinal and Outlet Drains - A Chimney drain has been included in the Main and Perimeter Embankments and is planned for the South Embankment. The chimney drains provide a contingency drainage measure for control of the phreatic surface in the embankment and will also function as a crack stopper downstream of the core zone. Water collected in the chimney drains is routed to the drain monitoring sumps via the longitudinal and outlet drains.

Upstream Toe Drains - An upstream toe drain has previously been installed in the Main Embankment and one is planned for installation in the Perimeter Embankment during the Stage 5 construction program. An upstream toe drain will be installed at the South Embankment during a future stage. The purpose of the upstream toe drains is to drain and consolidate the tailings mass near the embankments. The inclusion of upstream toe drains also provides seepage control within the embankment and reduces the likelihood of piping. Piezometer records at the Main Embankment indicate that the upstream toe drain is effective in draining the sandy tailings adjacent to the embankment.

The upstream toe drains also remove a certain amount of filtered water from the impoundment, and it may be possible to establish water discharge points below the seepage collection ponds if water quality objectives are met. Experience at the site has shown that the quality of water flowing from the toe drains is better than supernatant water quality for most parameters, largely because the suspended solids are effectively filtered before the water enters the drains. The installation of the upstream toe drains was recommended during an independent third party review conducted by Fred Matich of MATM in 1997 in a "Geotechnical Review, Drainage Aspects" for the Main Embankment.

The upstream toe drain at the Perimeter Embankment will exit the TSF at the west abutment in the in-situ foundation materials. The conduit through the abutment will consist of a concrete encased pipe, with the concrete encasement having sloped sides to allow for superior compaction of the earthfill materials against it. A filter diaphragm consisting of Zone F material will be constructed for seepage and piping control. The conduit will not contain seepage cut-off walls. Flows from the Perimeter Embankment upstream toe drain will flow into the sump located Perimeter Embankment Seepage Collection Pond for measurement and sampling prior to being recycled back to the TSF. Details of the upstream toe drain at the Perimeter Embankment are shown on Drawing 240.

2.6 SEEPAGE COLLECTION PONDS

The seepage collection ponds collect water from the embankment drain systems and from local runoff. The Main Embankment Seepage Collection Pond, located immediately downstream of the Main Embankment, was completed at the start of the Stage 1a construction program in 1997. The Perimeter Embankment Seepage Collection Pond was excavated during Stage 1b construction in 1997. These ponds were excavated in low permeability glacial till materials. A sump and seepage recycle pumpback system will be installed at the South Embankment during Stage 5.

2.7 INSTRUMENTATION

Piezometers

A total of 56 vibrating wire piezometers have been installed at the TSF to date. The piezometers are grouped into tailings, foundation, embankment fill and drain piezometers and have been installed along eight planes designated as Monitoring Planes A to H. An additional monitoring plane (Plane I) will be installed at the South Embankment. The piezometer locations are shown on Drawings 336, 338, 340, 346, 347, 348 and 349. The piezometers are read monthly during operations and weekly during TSF construction programs as per the OM&S Manual. The piezometer data is reviewed annually as part of the annual inspection. The piezometer records for the TSF have recently been reported in Knight Piésold Report "2005 Annual Inspection", (Ref. No. VA101-1/11-1, May 3, 2006).

Inclinometers

Five slope inclinometers have been installed to date at the toe of the Main Embankment through the lacustrine silts to measure potential deformation of the embankment materials. Three of the inclinometers were installed during the Stage 4 construction program. The inclinometers will be carefully extended through the shell zone material as it is raised. There have been no significant deviations in the inclinometers since they were installed.

Survey Monuments

The survey monuments installed on the Stage 3B embankment crest following the 2001 construction program were removed during the Stage 3C construction program and have not been replaced as the Stage 3C construction program blended into the Stage 4 construction program. New survey monuments may be installed on the embankment crests during the Stage 4 construction program depending on its completion date, otherwise, survey monuments will be installed following the Stage 5 construction program, which is scheduled for the summer and fall of 2006.

2.8 WATER MANAGEMENT

MPMC mine personnel complete on going surface water monitoring and water management activities to ensure compliance with the current mine permits. The water balance for the TSF is updated regularly by MPMC with periodic reviews by Knight Piésold. The water balance was recently reviewed by Knight Piésold in February 2006. The site climatic conditions were reviewed by Knight Piésold in 2004 and the water balance input parameters were adjusted accordingly to better reflect site conditions. The TSF is currently operating with a water budget surplus, as total inflows from precipitation and surface runoff exceed losses from evaporation, void retention and seepage removal. The TSF is required to have sufficient live storage capacity for containment of runoff from the 24-hour PMP volume of 679,000 m³ at all times, which would result in an incremental rise in the tailings pond level of approximately 0.39 m. The 24-hour PMP allowance is in addition to regular inflows from other precipitation runoff, including the spring freshet. The TSF design also incorporates an additional allowance of 1 meter of freeboard for wave run-up.

SECTION 3.0 - STAGE 5 TAILINGS STORAGE FACILITY DESIGN

3.1 GENERAL

The Stage 5 expansion of the TSF will involve raising the embankments to an elevation of 951 m. This corresponds to an increase in the crest elevation of 3 m and will provide storage for tailings and water for approximately 1 year of operations. The Stage 4 expansion of the TSF involved placing an upstream cap on the embankments to an elevation of 948 m. The Stage 5 construction of the TSF consists of expanding the embankments using the modified centreline construction method. This involves constructing the downstream shell zone (Zone C) to elevation 951 m concurrently with the Zones S, F, T and U. The design basis and operating criteria for the Stage 5 design of the TSF are shown on Table 3.1. The filling schedule and anticipated staged construction sequence of the TSF, which incorporates anticipated supernatant pond development over the next year, is shown on Figure 3.1.

Work to be completed during the Stage 5 expansion of the TSF includes the following:

- Placing the downstream shell zone material in two stages to coordinate the construction schedule with the material availability from the development of the Wight Pit. The first stage involves placing the shell zone with an interim slope of 1.4H:1V to allow the embankments to be raised using the modified centreline construction method in the timeline required to maintain the storage and free board requirements of the TSF. The shell zone will be expanded to a 2H:1V slope once the embankments have reached the Stage 5 design elevation.
- Expanding Zones S, F, T and U to elevation 951 m. The Zone S core zone will have a minimum width of 8 m. Zones F and T will be tied into the existing Zones F and T which are currently at an elevation of 944 m.
- Installing an upstream toe drain on the Perimeter Embankment to drain and consolidate the tailings mass near the embankment.
- Installing foundation drains and a sump and seepage recycle pumpback system at the South Embankment prior to placement of downstream shell zone material.
- Extending the slope inclinometers at the Main Embankment concurrently with the downstream shell zone.
- Installing additional vibrating wire piezometers at the existing monitoring planes with an additional plane being located at the South Embankment. The piezometer cables will be extended to readout boxes located beyond the ultimate toe of the embankments. The proposed locations of the new piezometers are shown on Drawings 346, 347, 348 and 349.
- Installing survey monuments on the Stage 5 crest.

The Stage 5 Main Embankment Plan, Section and Details are shown on Drawings 210, 215 and 216, respectively. The Stage 5 Perimeter Embankment Plan, Section and Details are shown on Drawings 220, 225 and 226, respectively. The Stage 5 South Embankment Plan and Sections are shown on Drawings 230 and 235, respectively. The material specifications are shown on Drawing 104. Longitudinal and foundation drain details for the South Embankment are shown on Drawing 236.

Knight Piésold will provide the construction drawings, technical specifications, and QA/QC for Stage 5 expansion of the TSF. Knight Piésold will also issue a construction report following the Stage 5 construction program.

3.2 STABILITY ANALYSIS

Stability analyses for the TSF embankments were performed using the limit equilibrium computer program SLOPE/W. Static and seismic stability analyses were conducted to investigate the stability of the Main and Perimeter Embankments during operations. Material parameters adopted for the tailings, foundation and earth embankment materials were based on testwork from the 1995 and 1997 geotechnical investigations, from the various quality control records obtained during construction of previous stages, and from experience with typical values for similar materials. The analyses were completed to model upstream and downstream stability and conservatively assumed a partially consolidated upstream tailings mass. The downstream stability analyses considered the interim 1.4H:1V shell zone slope and the 2H:1V shell zone slope.

The results of the SLOPE/W stability analyses indicate that the factor of safety for the Stage 5 TSF embankments for static conditions ranged from 1.5 to 1.9 and 1.7 to 2.0 for downstream shell zone slopes of 1.4H:1V and 2H:1V, respectively. The factor of safety for the upstream stability analyses under static conditions for the Perimeter and Main Embankments was greater than 2.0.

The seismic analyses were completed using ground accelerations of 0.037g for the OBE. The factor of safety for the Stage 5 TSF embankments for seismic conditions ranged from 1.4 to 1.7 and 1.6 to 1.8 for downstream shell zone slopes of 1.4H:1V and 2H:1V, respectively. The factors of safety for the upstream stability analyses under seismic conditions for the Perimeter and Main Embankments were greater than 2.0.

A post liquefaction analyses was also completed to provide a conservative assessment of the downstream stability of the TSF embankments assuming the tailings material liquefies and has a very low residual strength. The factors of safety for the Main and Perimeter Embankments for post liquefaction conditions ranged from 1.5 to 1.9 and 1.7 to 2.0 for shell zone slopes of 1.4H:1V and 2H:1V, respectively. The factors of safety for the upstream stability analyses under post liquefaction conditions for the Perimeter and Main Embankments were greater than 2.0.

The results of the stability analyses are summarised on Table 3.2. The results of the stability analyses indicate that the Stage 5 TSF embankments are stable under static, seismic, and post liquefaction conditions and that the embankments do not rely on the tailings mass for stability.

SECTION 4.0 - CERTIFICATION

This report was prepared and approved by the undersigned.

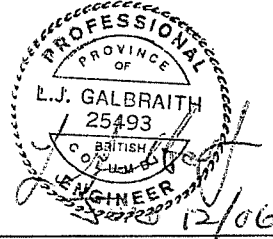

Prepared by:

Les Galbraith, P.Eng.
Senior Engineer

Approved by:

Ken J. Brouwer, P.Eng.
Managing Director

This report was prepared by Knight Piésold Ltd. for the account of Mount Polley Mining Corporation. The material in it reflects Knight Piésold's best judgement in light of the information available to it at the time of preparation. Any use which a third party makes of this report, or any reliance on or decisions to be made based on it, is the responsibility of such third parties. Knight Piésold Ltd. accepts no responsibility for damages, if any, suffered by any third party as a result of decisions made or actions, based on this report. This numbered report is a controlled document. Any reproductions of this report are uncontrolled and may not be the most recent revision.

TABLE 3.1

**MOUNT POLLEY MINING CORPORATION
MOUNT POLLEY MINE**

STAGE 5 DESIGN BASIS AND OPERATING CRITERIA

Print: 6-Jun-06

Revised: 15-Feb-06

M:\1101\00001\12\A\Report\Tables\Table 3.1.Doc

| ITEM | DESIGN CRITERIA |
|--|--|
| 1.0 GENERAL DESIGN CRITERIA | |
| Regulations | MEM, WLAP |
| Codes and Standards | ASTM, ACI, ANSI, CSA, CDSA, HSRC (Health, Safety and Reclamation Code for Mines in BC), NBC and related codes |
| Design Operating Life | 10 Years |
| Tailings Production Information | 20,000 tonnes/day, 35% solids, 2.65 SG, 76 million tonnes total production, 1.36 tonnes/m ³ final average tailings dry density |
| Hazard Rating: | HIGH by CDA Consequence Classification / British Columbia Dam Safety Regulation of the Water Act |
| Site Elevation | 910 to 1150 metres |
| Climate | Average Annual Rainfall = 740 mm, Annual Evaporation = 423 mm, Mean Annual Temp = 4.0 C (Likely), Design 24-hour PMP storm = 203 mm. |
| Design Earthquakes: OBE (operations) MDE (closure) | 1 in 475 Year Event (M = 6.5, A _{max.} = 0.037 g). 50% of the 1 in 2500 Year Event or MCE (M = 6.5, A _{max.} = 0.065 g). |
| Seepage Control | Low permeability glacial till liners (natural and constructed) in basin, with foundation drain system below main embankment. Foundation and chimney drain seepage is contained within the seepage collection ponds. |
| Tailings Pipework | Butt fusion welded HDPE pipe, gravity flow, discharge predominantly from embankment, spill containment by gravity flow to tailings basin. |
| 2.0 TAILINGS BASIN | |
| Geological and Geotechnical Conditions | The TSF basin and foundation comprises glacial soils of variable permeability and strength. |
| Basin Liner | <ul style="list-style-type: none"> In-situ low permeability glacial till, or Constructed glacial till liner. Required in areas with <2 m depth of in-situ glacial till. |
| Embankment Foundation Drains | <ul style="list-style-type: none"> Installed in Main and Perimeter Embankment foundations. Foundation drains to be installed at the South Embankment during the Stage 5 expansion. Foundation drains discharge to the seepage collection ponds at the Main and Perimeter Embankments via drain monitoring sumps. The foundation drain at the South Embankment will discharge to a sump where the flows will be monitored and pumped back to the TSF. |
| Stripping | <ul style="list-style-type: none"> Required at areas directly affected by construction (embankments, basin liners, seepage collection ponds, reclaim barge channel stockpiles, road, etc). Remove organic soil to topsoil stockpiles |

TABLE 3.1

MOUNT POLLEY MINING CORPORATION
MOUNT POLLEY MINE

STAGE 5 DESIGN BASIS AND OPERATING CRITERIA

Print: 6-Jun-06

Revised: 15-Feb-06

M:\1\01\00001\12\A\Report\Tables\Table 3.1.Doc

| 3.0 TAILINGS EMBANKMENT | | | | | | | |
|--|--|------------|--|---------|--|-------|-----------|
| Function | <ul style="list-style-type: none"> Storage of tailings and process water for design life Provide emergency containment of runoff for 24-hour PMP storm Provision for routing PMF at closure | | | | | | |
| Embankment Crest Width | 8m min for Zone S. | | | | | | |
| Embankment Height: | <table border="0"> <tr> <td>Current</td> <td>El. 947 m (March 2006)</td> </tr> <tr> <td>Stage 5</td> <td>El. 951 m</td> </tr> <tr> <td>Final</td> <td>El. 965 m</td> </tr> </table> | Current | El. 947 m (March 2006) | Stage 5 | El. 951 m | Final | El. 965 m |
| Current | El. 947 m (March 2006) | | | | | | |
| Stage 5 | El. 951 m | | | | | | |
| Final | El. 965 m | | | | | | |
| Design Tonnage | 7,300,000 tpy (20,000) tpd | | | | | | |
| Solids Content of Tailings Stream | 35% (before Millsite and waste dump runoff added to tailings stream) | | | | | | |
| Freeboard: | <table border="0"> <tr> <td>Operations</td> <td>24-hour PMP event (679,000 m³) plus 1.0 m wave run.</td> </tr> <tr> <td>Closure</td> <td>Sufficient to provide routing of PMF plus wave run-up.</td> </tr> </table> | Operations | 24-hour PMP event (679,000 m ³) plus 1.0 m wave run. | Closure | Sufficient to provide routing of PMF plus wave run-up. | | |
| Operations | 24-hour PMP event (679,000 m ³) plus 1.0 m wave run. | | | | | | |
| Closure | Sufficient to provide routing of PMF plus wave run-up. | | | | | | |
| Storage Capacity | 85 million tonnes (Crest Elevation of 965 m). | | | | | | |
| Tailings Density: | 1.36 t/m ³ | | | | | | |
| Tailings Specific Gravity | 2.70 | | | | | | |
| Emergency Spillway Flows: | <table border="0"> <tr> <td>Operations</td> <td>Not required.</td> </tr> <tr> <td>Closure</td> <td>Design flow for routing PMF event.</td> </tr> </table> | Operations | Not required. | Closure | Design flow for routing PMF event. | | |
| Operations | Not required. | | | | | | |
| Closure | Design flow for routing PMF event. | | | | | | |
| Filling Rate | Refer to Figure 2.1. | | | | | | |
| Fill Material / Compaction Requirements | Refer Drawing 101-1/12-104. | | | | | | |
| Sediment Control | Primary control provided by the TSF Embankments. Secondary control provided by the seepage collection ponds. | | | | | | |
| Seepage Control | Seepage collection ponds and pumpback well systems. | | | | | | |
| Spillway Discharge Capacity | Not required during operations. | | | | | | |
| Surface Erosion Protection | Re-vegetation with grasses on final embankment slope. | | | | | | |
| 4.0 PIPEWORKS | | | | | | | |
| 4.1 Tailings Pipeworks | | | | | | | |
| Function | Transport tailings slurry and mill site and waste dump runoff to TSF. | | | | | | |
| Tailings Pipeline | <ul style="list-style-type: none"> Free draining, gravity flow pipeline. Butt fusion welded HDPE with 24" / 30" DR15.5 and 22" DR17. | | | | | | |
| Spigots | <ul style="list-style-type: none"> Movable discharge section placed on tailings embankment crest. | | | | | | |
| Flow Rate | <ul style="list-style-type: none"> Design throughput 770 tonnes/hr dry solids. Slurry solids content 35%. Design flow 19.6 cfs (0.55m³/s). Increases to 23.8 cfs (0.67m³/s) at 30% solids content with addition of 4.2 cfs storm water runoff. <p>Waste dump and Millsite runoff added to tailings stream, increasing flow and decreasing solids content.</p> | | | | | | |
| Spill Containment: <i>Mill site to Bootjack Creek</i> <i>Bootjack Creek Crossing</i> <i>Bootjack Creek to TSF</i> | <ul style="list-style-type: none"> Pipeline laid in pipe containment channel. There is an overflow pond for the T2 Dropbox. Pipeline sleeved in pipe containment channel. Pipeline laid in pipe containment channel. | | | | | | |

TABLE 3.1

**MOUNT POLLEY MINING CORPORATION
MOUNT POLLEY MINE**

STAGE 5 DESIGN BASIS AND OPERATING CRITERIA

Print: 6-Jun-06

M:\101\00001\12\A\Report\Tables\Table 3.1.Doc

Revised: 15-Feb-06

| | |
|------------------------------------|---|
| 4.2 Reclaim Water System | |
| Function | Primary source of water for milling process. (Pump and Barge System Designed by Others.) |
| Reclaim Barge | <ul style="list-style-type: none"> Prefabricated pump station on barge in excavated channel in TSF. Local and remote control from Millsite. |
| Reclaim Pipeline | <ul style="list-style-type: none"> 24" pipeline with a steel section at the reclaim barge and HDPE with varying pressure ratings along length. |
| Reclaim Booster Pump Station | <ul style="list-style-type: none"> Prefabricated pump station located between TSF and Millsite. Identical pumps, sensors and controls as reclaim barge for ease of maintenance. |
| Spill Containment | <ul style="list-style-type: none"> See Item 4.1 above. Booster pump station has closed sump. |
| 4.3 Seepage Recycle System | |
| Function | Return seepage and foundation drain flows to TSF. |
| Drain Monitoring Sumps | Flow quantity and water quality measurements on individual drains. |
| Seepage Collection Ponds | <ul style="list-style-type: none"> Sized to hold 10 times maximum weekly seepage flow quantity. Excavated in low permeability natural soils, operated as groundwater sink. |
| Seepage Recycle Pumps | <ul style="list-style-type: none"> Set in vertical pump sumps. Submersible pumps, system by Others. Pumps discharge back to TSF via 150 mm HDPE pipes. |
| 5.0 WATER MANAGEMENT | |
| 5.1 General | |
| | To contain runoff from disturbed project areas when and as required to meet the project Water Management Plan objectives. |
| 5.2 Millsite Sump | |
| Catchment Area | Approx. 20 ha direct catchment, plus pit dewatering. |
| Design Storm | 1.5 x 1 in 10 yr. 24 hour event runoff (6,000 m ³) |
| Sump Cross-Section | 3:1 inside slope, 2:1 outside slope, 4m crest width. |
| Normal Operating Level | 1102.7 m |
| Maximum Operating Level | 1106.2 m |
| Flow Control Structures | Reference Report 1627/2, Drawing No. 1625.232. |
| Discharge Pipe | 300 mm HDPE DR 21 to plant or tailings line. |
| Flow Monitoring | None. |
| 5.3 Southeast Sediment Pond | |
| Catchment Area | Approx. 150 ha direct catchment. |
| Design Storm | 1 in 10 yr. 24 hour event runoff (25,000 m ³) |
| Sump Cross-Section | 3:1 inside slope, 2:1 outside slope, 4m crest width. |
| Normal Operating Level | 1054.5 m |
| Maximum Operating Level | 1057.4 m |
| Flow Control Structures | Reference Report 1627/2, Drawing No. 1625.232. |
| Discharge Pipe | 250 mm HDPE DR 21 to Reclaim sump or T2 Dropbox |
| Flow Monitoring | None. |

TABLE 3.1

**MOUNT POLLEY MINING CORPORATION
MOUNT POLLEY MINE**

STAGE 5 DESIGN BASIS AND OPERATING CRITERIA

Print: 6-Jun-06
Revised: 15-Feb-06

M:\1101\00001\12\A\Report\Tables\Table 3.1.Doc

| | |
|--|--|
| 5.4 Polley Lake Pump Station | Reference Report 1628/5. Used for supply of additional makeup water during initial years of operation. Dismantled and no longer required. |
| 5.5 Caribou Pit | |
| | Pit used for disposal of excess tailings pond water during care and maintenance period. |
| INSTRUMENTATION AND MONITORING | |
| 6.1 General | To quantify environmental conditions and performance characteristics of the TSF to ensure compliance with design objectives. |
| 6.2 Geotechnical Instrumentation and Monitoring | |
| Piezometers | <ul style="list-style-type: none"> • Measure pore pressures in drains, foundations, fill materials and tailings. • Vibrating wire piezometers. • Installed by qualified technical personnel. • Four instrumentation planes for Main Embankment, three for the Perimeter Embankment, and two for the South Embankment. • 56 piezometers installed to date. |
| Survey Monuments | <ul style="list-style-type: none"> • Deformation and settlement monitoring of embankments. |
| Inclinometers | <ul style="list-style-type: none"> • Measure potential deformation of the embankment materials. • Installed by qualified technical personnel. • Two slope inclinometers installed at the toe of the Main Embankment. Three additional slope inclinometers installed downstream of the Main Embankment during Stage 4. |
| 6.3 Flow Monitoring | <ul style="list-style-type: none"> • To provide data for on-going water balance calculations. • Drain flows regularly monitored. • Reclaim and seepage pump systems flow meters. • Tailings output monitored at millsite. • Stream flow monitoring. |
| 6.4 Water Quality Monitoring | <ul style="list-style-type: none"> • To ensure environmental compliance. • Water quality samples taken at regular intervals from sediment ponds, drains (at drain monitor sump), groundwater monitoring wells, seepage ponds and tailings pond. • Upstream and downstream samples for impact analysis. |
| 6.5 Hydrometeorology | <ul style="list-style-type: none"> • Site weather station for input to water balance calculations. • Site monitoring of precipitation (rain and snow), evaporation, air quality monitoring (dust, etc.). |
| 6.6 Operational Monitoring | <ul style="list-style-type: none"> • Quantify operation of tailings storage facility. • Rate of tailings accumulation in terms of mass and volume. • Tailings characteristics and water recovery. • Supernatant pond (depth, area and volume). |

TABLE 3.1

MOUNT POLLEY MINING CORPORATION
MOUNT POLLEY MINE

STAGE 5 DESIGN BASIS AND OPERATING CRITERIA

Print: 6-Jun-06

M:\1\01\00001\12\A\Report\Tables\Table 3.1.Doc

Revised: 15-Feb-06

| CLOSURE REQUIREMENTS | |
|-----------------------------|---|
| 7.1 General | Return impoundment to equivalent pre-mining use and productivity by establishing a wetland area adjacent to a final spillway and re-vegetating remainder of tailings surface with indigenous species of trees, shrubs and grasses adjacent to embankment grading to aquatic species along and adjacent to final pond. |
| 7.2 Spillway | Two stage spillway with lower channel outlet designed to pass 1 in 200 yr. 24 hour flood event and upper wider outlet section designed to pass PMF without overtopping embankments. Designed to consider protection against beaver dams. |

Notes:

1. The closure plan will remain flexible during operations to allow for future changes in the mine plan and to incorporate information from on-going reclamation programs.

TABLE 3.2

MOUNT POLLEY MINING CORPORATION
MOUNT POLLEY MINE

STABILITY ANALYSES SUMMARY

Rev'd 05/24/06

M:\1\01\00001\12\A\Report\Tables\[Table 3.2.xls]Table 3.2 Rev 0

Printed 5/26/2006

| Stage 5 Embankment Section | | Minimum Factor of Safety | |
|------------------------------------|-----------|-----------------------------|-------------------|
| | | Shell Zone Downstream Slope | |
| | | 1.4:1 (interim slope) | 2:1 (final slope) |
| Static Stability | | | |
| Downstream | Main | 1.5 | 1.7 |
| | Perimeter | 1.9 | 2.0 |
| Upstream | Main | > 2.0 | > 2.0 |
| | Perimeter | > 2.0 | > 2.0 |
| Seismic Stability | | | |
| Downstream | Main | 1.4 | 1.6 |
| | Perimeter | 1.7 | 1.8 |
| Upstream | Main | > 2.0 | > 2.0 |
| | Perimeter | > 2.0 | > 2.0 |
| Post Liquefaction Stability | | | |
| Downstream | Main | 1.5 | 1.7 |
| | Perimeter | 1.9 | 2.0 |
| Upstream | Main | > 2.0 | > 2.0 |
| | Perimeter | > 2.0 | > 2.0 |

Rev 0 - Issued for Report

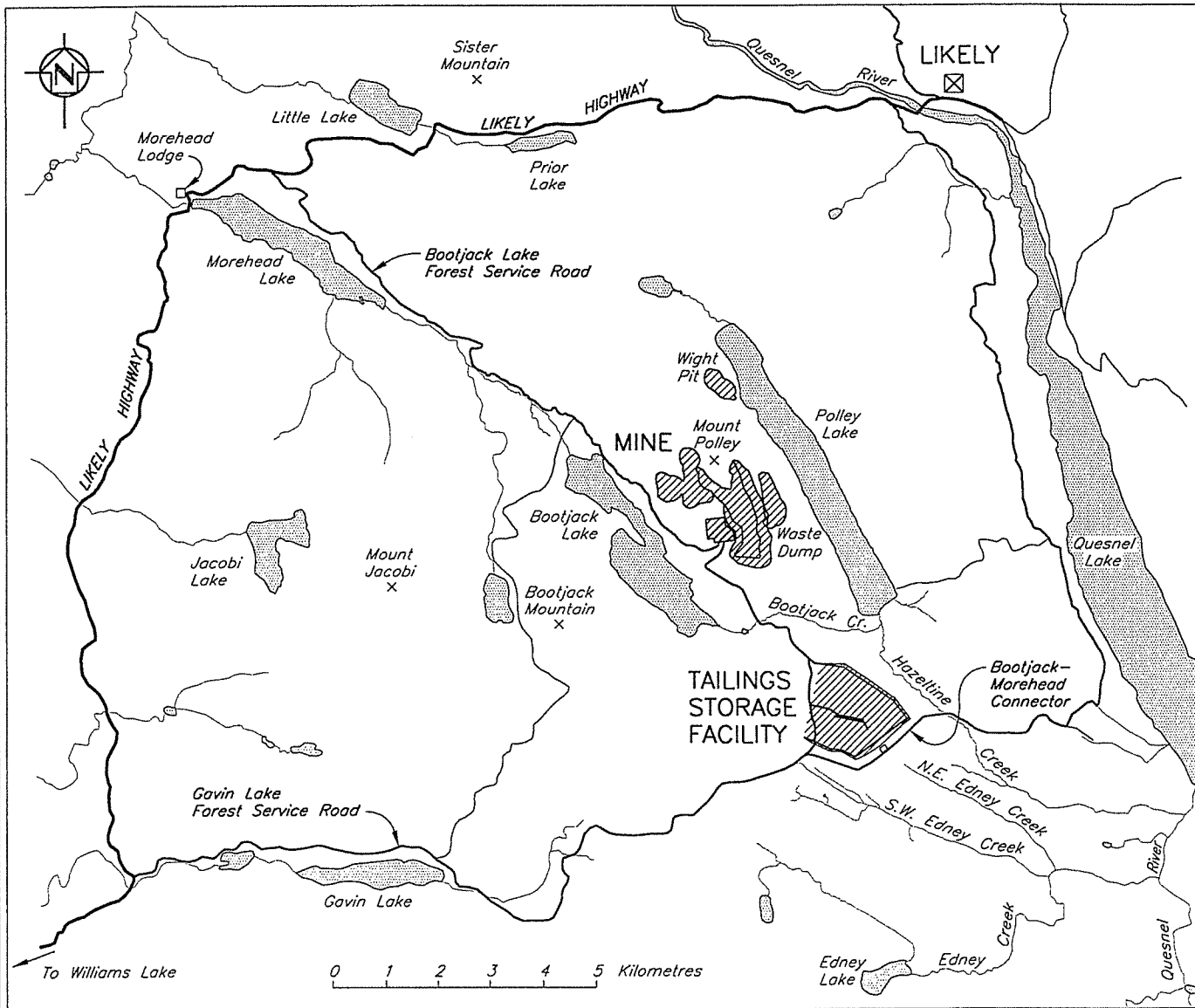

LOCATION MAP

| | |
|-------------------------------------|--------------------------------------|
| MOUNT POLLEY MINING CORPORATION | |
| MOUNT POLLEY MINE | |
| PROJECT LOCATION AND ACCESS PLAN | |
| Knight Piésold CONSULTING | PROJECT/ASSIGNMENT NO. VA101-1/12 |
| | REF. NO. 1 |
| FIGURE 1.1 | |
| REV. 0 | REV. 0 |

XREF FILE : -

REV. 0 09JUN'06 ISSUED FOR REPORT

CAD FILE: M:\1\01\00001\2\VA\Access\Fig\M01.DWG 1-125000 PLOT 1-1 (05) Jun 09 2006 by:sheds Time @ 13:24



Notes:

1) Photograph taken in October 2005

| | | |
|---|---|--------------|
| MOUNT POLLEY MINING CORPORATION | | |
| MOUNT POLLEY MINE | | |
| AERIAL PHOTOGRAPH OF MOUNT POLLEY MINE VIEWING NORTH | | |
| <i>Knight Piésold</i> CONSULTING | PROJECT / ASSIGNMENT NO. VA 101-1/12 | REF NO. 1 |
| | FIGURE 1.2 | |
| | REV. 0 | |





Notes:

1) Photograph taken in October 2005

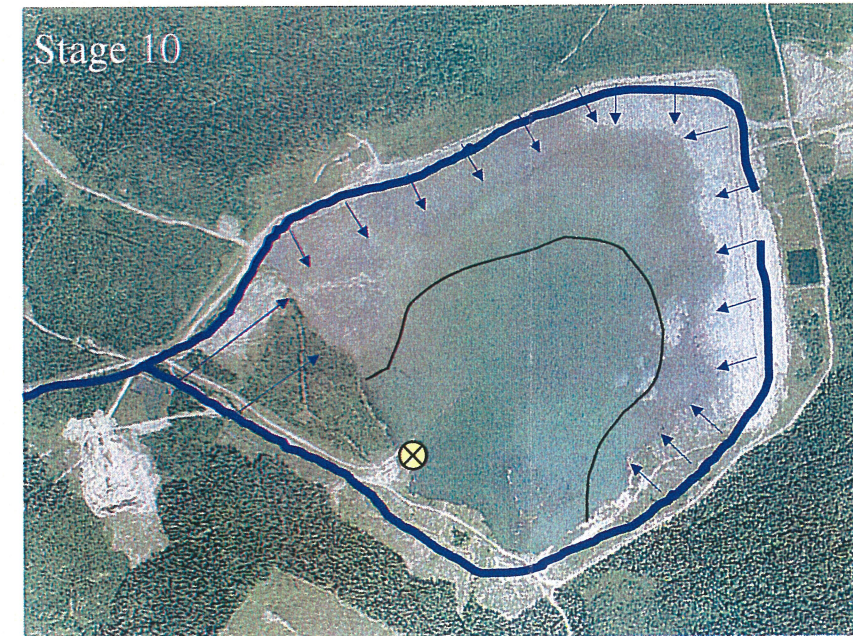
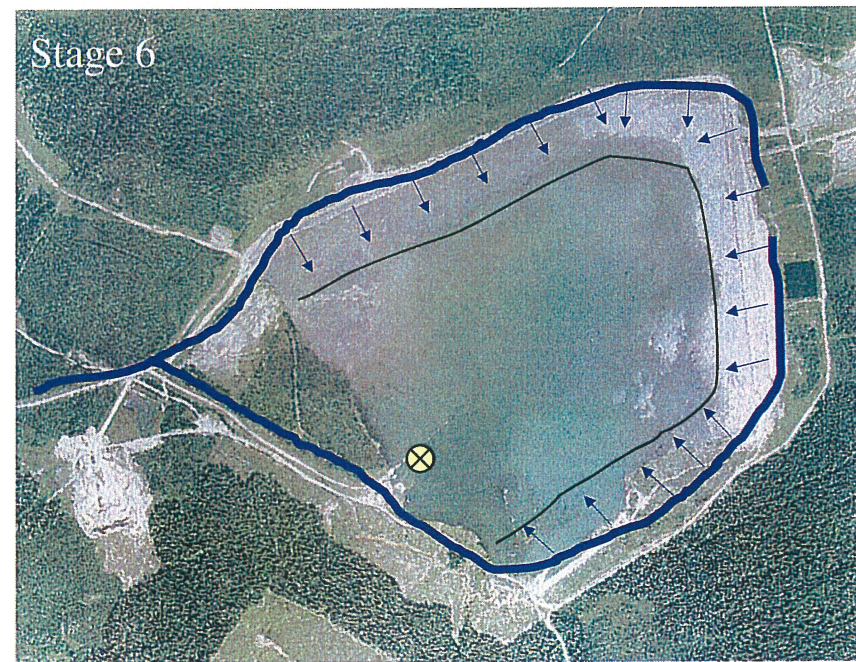
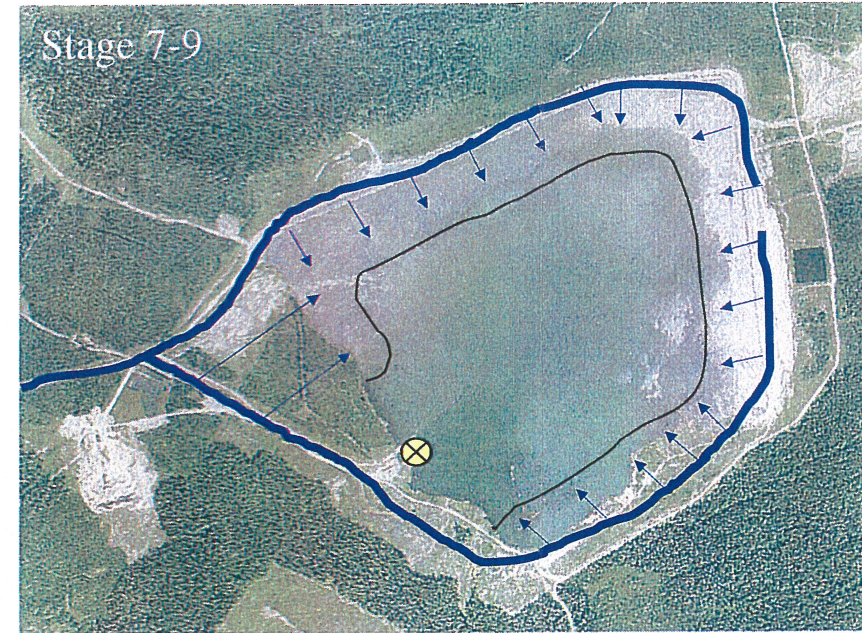
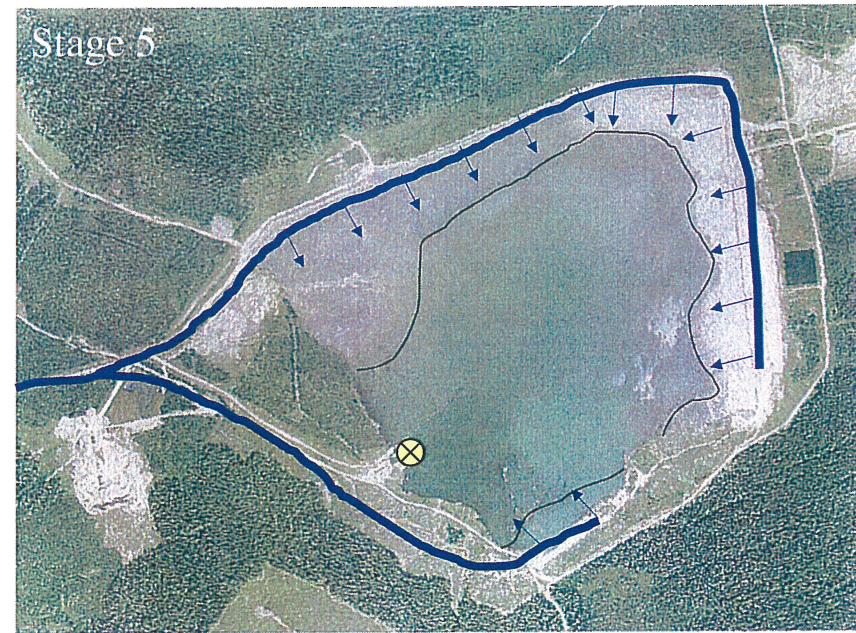
| | | |
|---|---|--------------|
| MOUNT POLLEY MINING CORPORATION | | |
| MOUNT POLLEY MINE | | |
| AERIAL PHOTOGRAPH OF MOUNT POLLEY MINE VIEWING SOUTH | | |
| <i>Knight Piésold</i> CONSULTING | PROJECT / ASSIGNMENT NO. VA 101-1/12 | REF NO. 1 |
| | FIGURE 1.3 | |
| | | REV. 0 |



-  = Reclaim Barge
-  = Proposed Tailings Delivery Pipelines
-  = Proposed Tailings Discharge Locations

| | | |
|--|----------------------------|-------------------|
| MOUNT POLLEY MINING CORPORATION | | |
| MOUNT POLLEY MINE | | |
| TAILINGS STORAGE FACILITY TAILINGS DEPOSITION STRATEGY STAGE 5 TO STAGE 10 | | |
| <i>Knight Piésold</i> CONSULTING | PROJECT NO. VA 101-1/12 | REF. NO. 1 |
| | REV. 0 | FIGURE 2.1 |

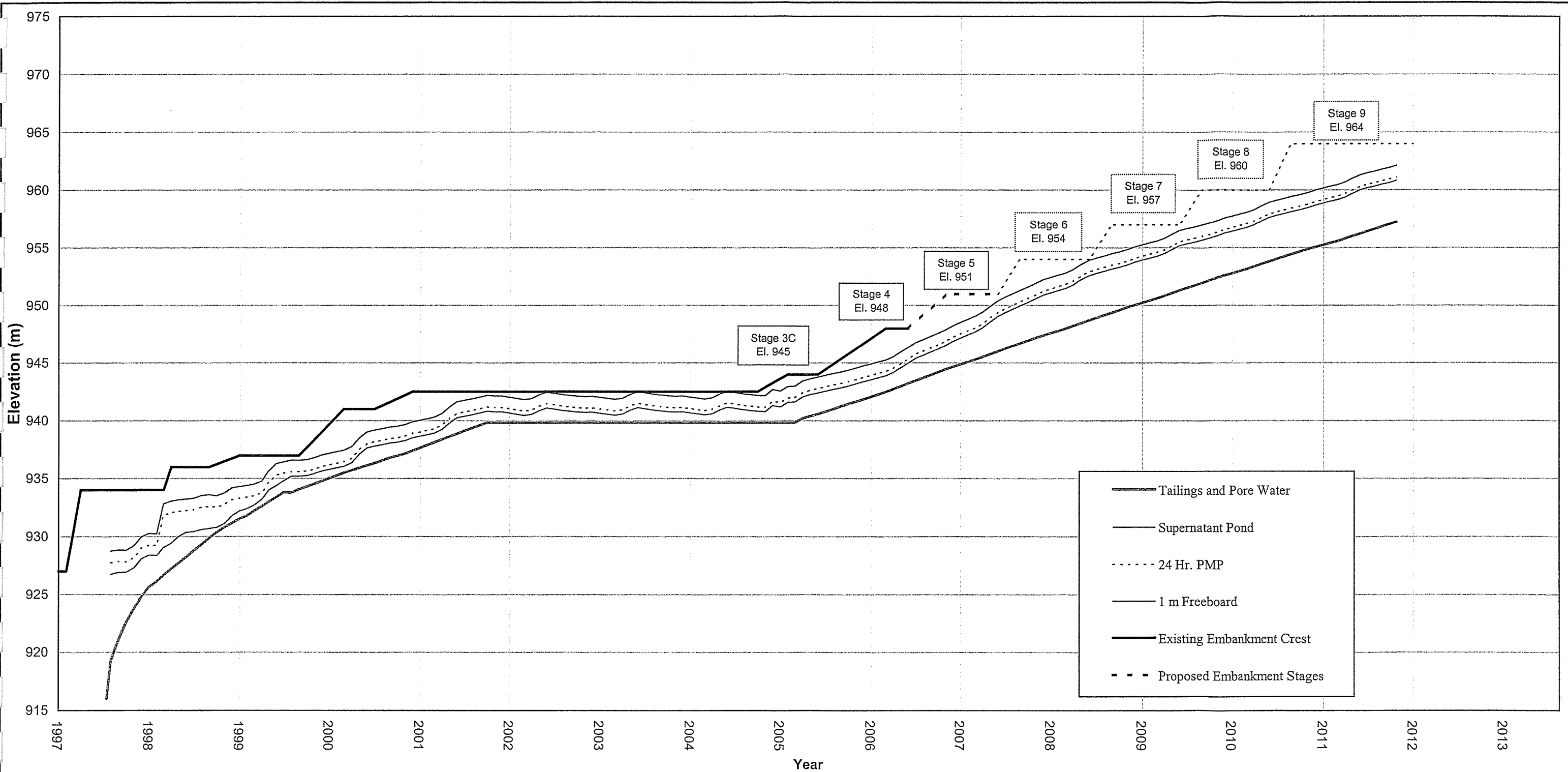

Notes:

1. Production rate is estimated 20,000 tpd.
2. Projected bulk tailings dry density is 1.36 t/m³ for tailings reporting to the TSF after August 2000.
3. The filling schedule will be updated as required to reflect actual mine throughput and the supernatant pond volume.

| | | |
|---|----------------------------|---------------|
| MOUNT POLLEY MINING CORPORATION | | |
| MOUNT POLLEY MINE | | |
| TAILINGS STORAGE FACILITY FILLING SCHEDULE | | |
| <i>Knight Piésold</i> CONSULTING | PROJECT NO. VA 101-1/12 | REF. NO. 1 |
| | | REV. 0 |
| FIGURE 3.1 | | |

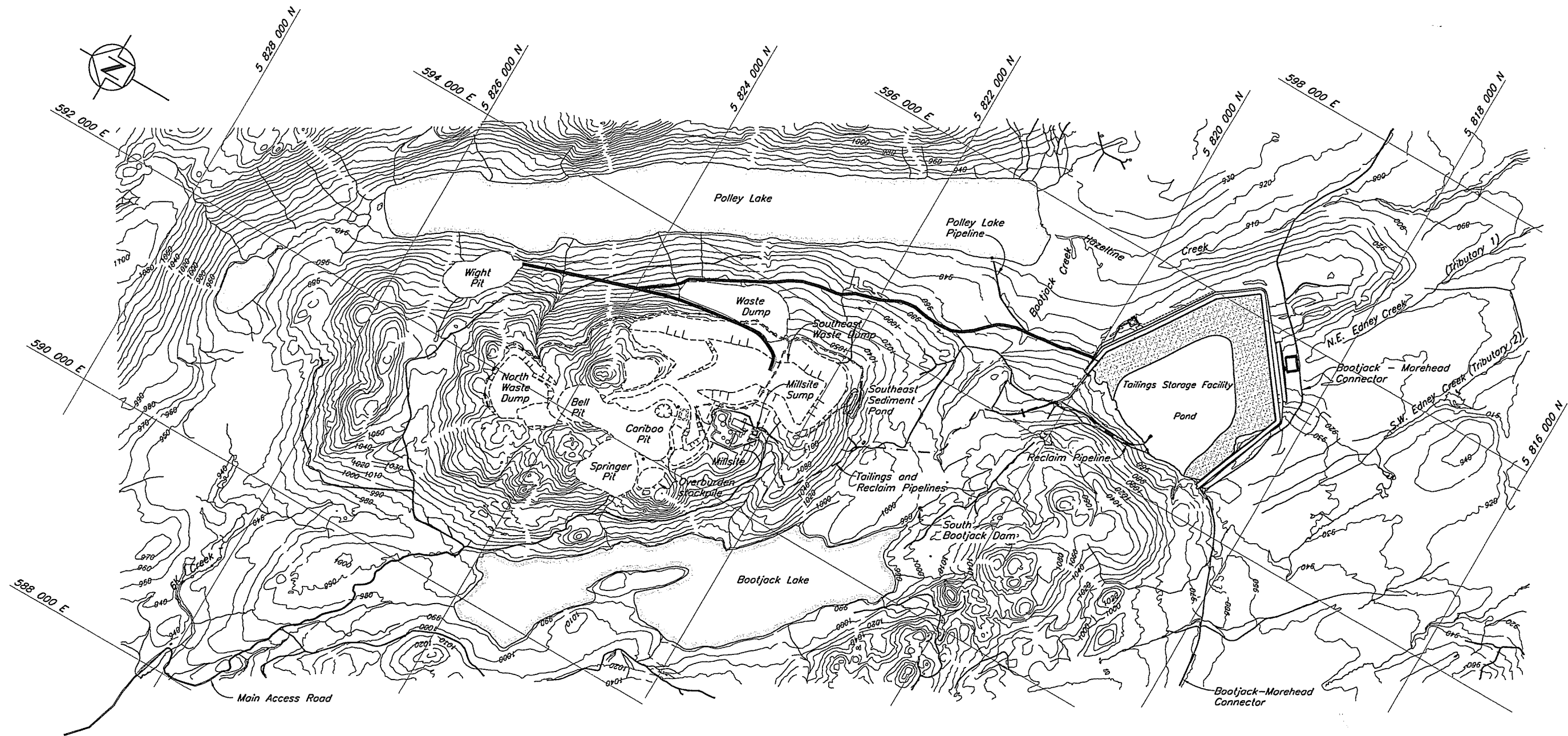

NOT FOR CONSTRUCTION



NOTES

1. Open Pits and Waste Dumps are shown in their final configurations.
2. Topography at TSF generated from points and break lines sent from MPMC in July 1999. The topography outside the TSF area is from 1997 flyover. UTM, NAD83, ZONE 10.
3. Drawing is for reference only.

- DISCLAIMER -
 THIS DRAWING WAS PREPARED BY KNIGHT PIÉSOLD LTD. FOR THE ACCOUNT OF THE CLIENT LISTED ON THIS DRAWING. THE MATERIAL ON IT REFLECTS KNIGHT PIÉSOLD'S BEST JUDGEMENT IN THE LIGHT OF THE INFORMATION AVAILABLE TO IT AT THE TIME OF PREPARATION. ANY USE WHICH A THIRD PARTY MAKES OF THIS DRAWING, OR ANY RELIANCE ON OR DECISIONS TO BE MADE BASED ON IT, ARE THE RESPONSIBILITY OF SUCH THIRD PARTIES. KNIGHT PIÉSOLD ACCEPTS NO RESPONSIBILITY FOR DAMAGES, IF ANY, SUFFERED BY THE THIRD PARTY AS A RESULT OF DECISIONS MADE OR ACTIONS BASED ON THIS DRAWING. COPIES RESULTING FROM ELECTRONIC TRANSFER OR REPRODUCTION OF THIS DRAWING ARE UNAUTHORIZED AND MAY NOT BE THE MOST RECENT REVISION OF THIS DRAWING.

PROVINCIAL ENGINEER
 L.J. GALBRAITH
 125493
 31 JUN 06

Knicht Piésold CONSULTING

MOUNT POLLEY MINING CORPORATION

MOUNT POLLEY MINE

OVERALL SITE PLAN

PROJECT/ASSIGNMENT NO. **VA101-1/12** DRAWING NO. **100** REVISION **0**

XREF FILE: TOP059

| DRG. NO. | DESCRIPTION | REV. | DATE | DESIGN | DRAWN | CHK'D | APP'D |
|----------|--------------------|------|------|--------|-------|-------|-------|
| | REFERENCE DRAWINGS | | | | | | |
| | REVISIONS | | | | | | |
| | REVISIONS | | | | | | |

| REV. | DATE | DESCRIPTION | DESIGN | DRAWN | CHK'D | APP'D |
|------|---------|-------------------------------|--------|-------|-------|-------|
| 0 | 26MAY06 | ISSUED FOR STAGE 5 PERMITTING | LJC | TAM | BS | KIS |

CAD FILE: \\101\00000\112\VA\Asset\Draw\100\100_1-20000_Plot_1-10P5 June 6 2005.tam
 VMC000000 B.C.



- NOTES**
1. Topography from 2004 Flyover
 2. All dimensions in millimetres and elevations in metres, unless noted otherwise.

NOT FOR CONSTRUCTION

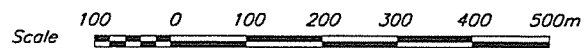

- DISCLAIMER -
 THIS DRAWING WAS PREPARED BY KNIGHT PIESOLD LTD. FOR THE ACCOUNT OF THE CLIENT LISTED ON THIS DRAWING. THE MATERIAL ON IT REFLECTS KNIGHT PIESOLD'S BEST JUDGEMENT IN THE LIGHT OF THE INFORMATION AVAILABLE TO IT AT THE TIME OF PREPARATION. ANY USE WHICH A THIRD PARTY MAKES OF THIS DRAWING OR ANY RELIANCE ON OR REASON TO BE MADE BASED ON IT, AND THE RESPONSIBILITY OF SUCH THIRD PARTIES, KNIGHT PIESOLD ACCEPTS NO RESPONSIBILITY FOR DAMAGES, IF ANY, SUFFERED BY THE THIRD PARTY AS A RESULT OF DECISIONS MADE OR ACTIONS BASED ON THIS DRAWING. COPIES RESULTING FROM ELECTRONIC TRANSFER OR REPRODUCTION OF THIS DRAWING ARE UNAUTHORIZED AND MAY NOT BE THE MOST RECENT REVISION OF THIS DRAWING.

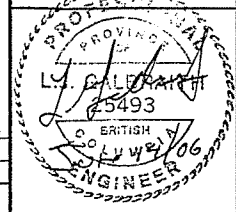

Knight Piesold
 CONSULTING

MOUNT POLLEY MINING CORPORATION

MOUNT POLLEY MINE

TAILINGS STORAGE FACILITY
 GENERAL ARRANGEMENT
 STAGE 5 CREST ELEVATION

| DRG. NO. | DESCRIPTION | REV. | DATE |
|----------|--------------------|------|------|
| - | REFERENCE DRAWINGS | - | - |

| DESIGN | DRAWN | CHK'D | APP'D | REVISIONS |
|--------|-------|-------|-------|-----------|
| | | | | |

| REV. | DATE | DESCRIPTION | DESIGN | DRAWN | CHK'D | APP'D | REVISIONS |
|------|----------|-------------------------------|--------|-------|-------|-------|-----------|
| 0 | 26MAY'06 | ISSUED FOR STAGE 5 PERMITTING | HPD | TAM | RSB | KJS | |

| | | |
|--------------------------------------|--------------------|---------------|
| PROJECT/ASSIGNMENT NO. VA101-1/12 | DRAWING NO. 102 | REVISION 0 |
|--------------------------------------|--------------------|---------------|

CAD FILE: M:\VA101\0000112\VA101\Kasid\02\102_1-5000_Plot_1-11(05). June 6 2006 lam
 VANCOUVER B.C.

UNIFIED SOIL CLASSIFICATION SYSTEM

ZONE S

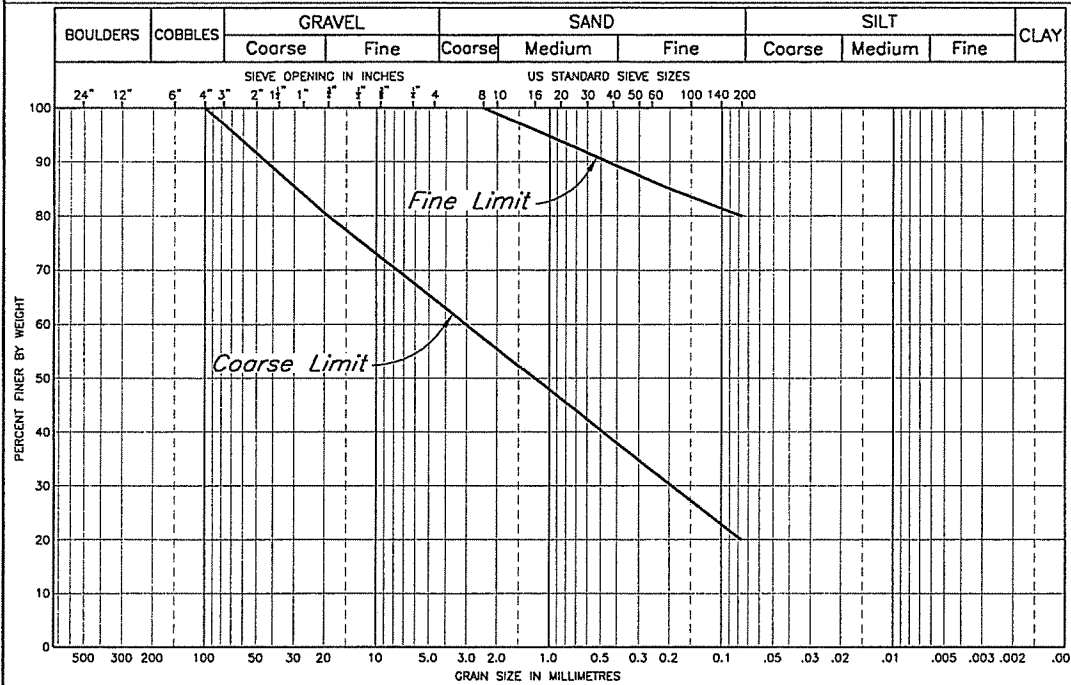

UNIFIED SOIL CLASSIFICATION SYSTEM

ZONE T and ZONE C

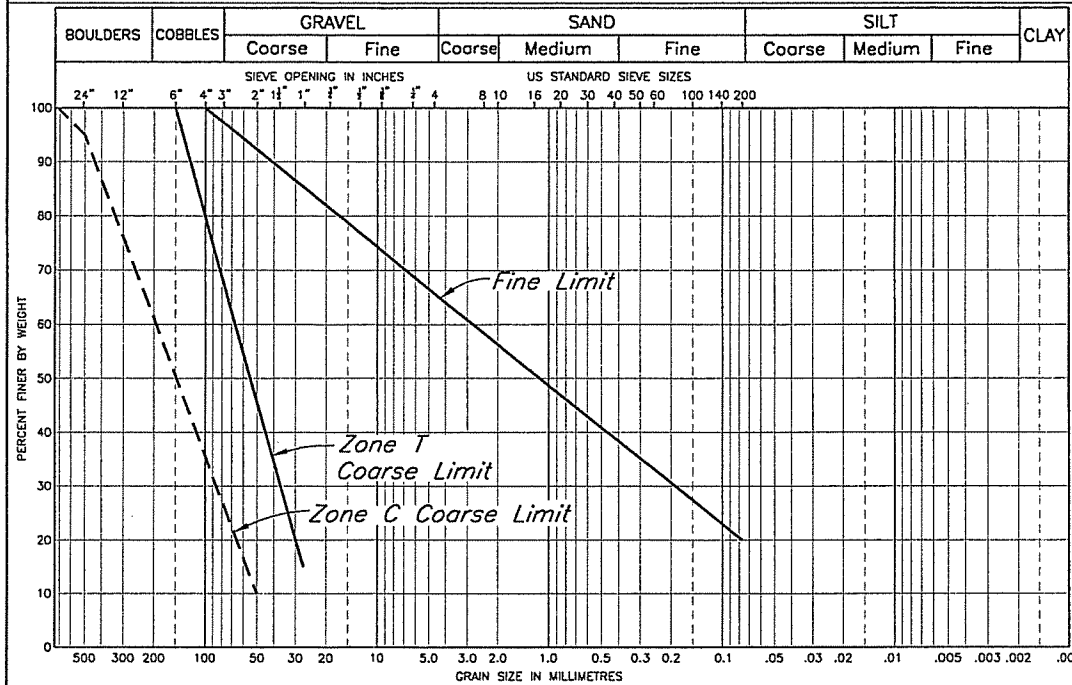

| ZONE | MATERIAL TYPE | LOCATION | PLACEMENT & COMPACTION REQUIREMENTS |
|------|------------------------|------------------------------------|--|
| S | Glacial till | Core Zone | Placed, moisture conditioned and spread in maximum 300 mm thick layers (after compaction). Vibratory compaction to 95% of Standard Proctor maximum dry density or as approved by the Engineer. |
| | Rock | Shell Zone | Placed and spread in maximum 2000 mm thick layers and compacted by selective routing of mine haul trucks. |
| T | Rock | Transition Zone/ Confining Berm | Placed and spread in maximum 600 mm thick layers and compacted with minimum 4 passes of 10 ton smooth drum vibratory roller, or as approved by the Engineer. |
| F | Filter sand | Chimney Drain | Placed and spread in maximum 600 mm thick layers and compacted with minimum 4 passes of 10 ton smooth drum vibratory roller, or as approved by the Engineer. |
| U | Select Fill | Upstream Toe | Placement and compaction requirements to be determined based on material selection. |
| CBL | Select Coarse Rockfill | Upstream Toe | Placed to establish a firm foundation for subsequent fill placement. |
| | Drainage Gravel | Drains | Placed around drainage pipes and wrapped with geotextile. |

UNIFIED SOIL CLASSIFICATION SYSTEM

ZONE F

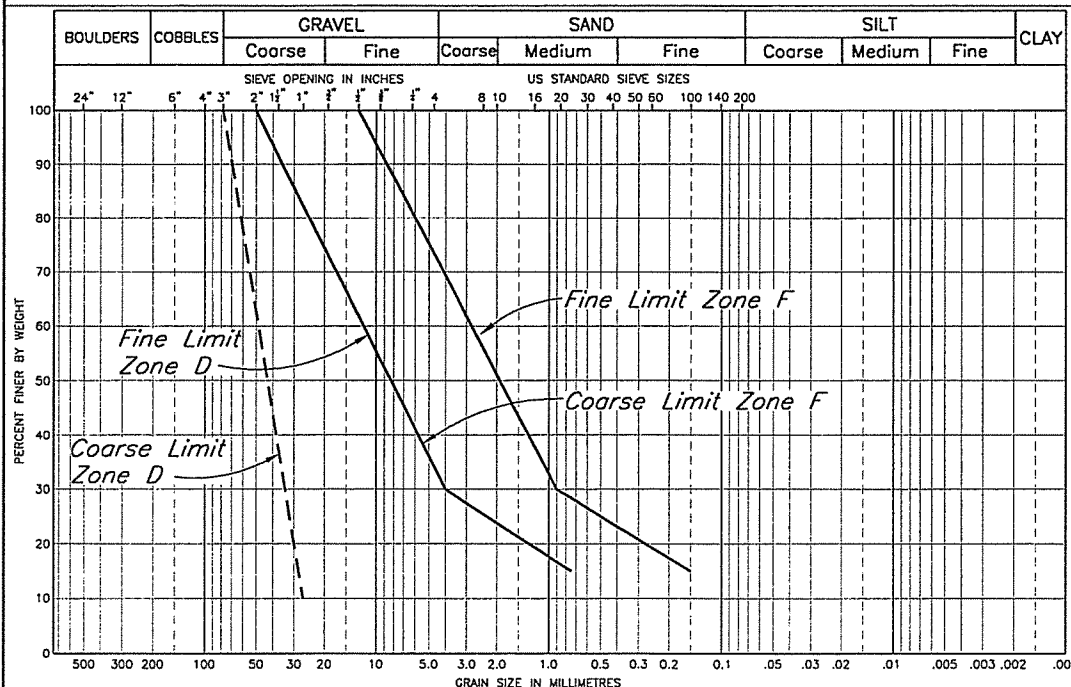

UNIFIED SOIL CLASSIFICATION SYSTEM

ZONE U

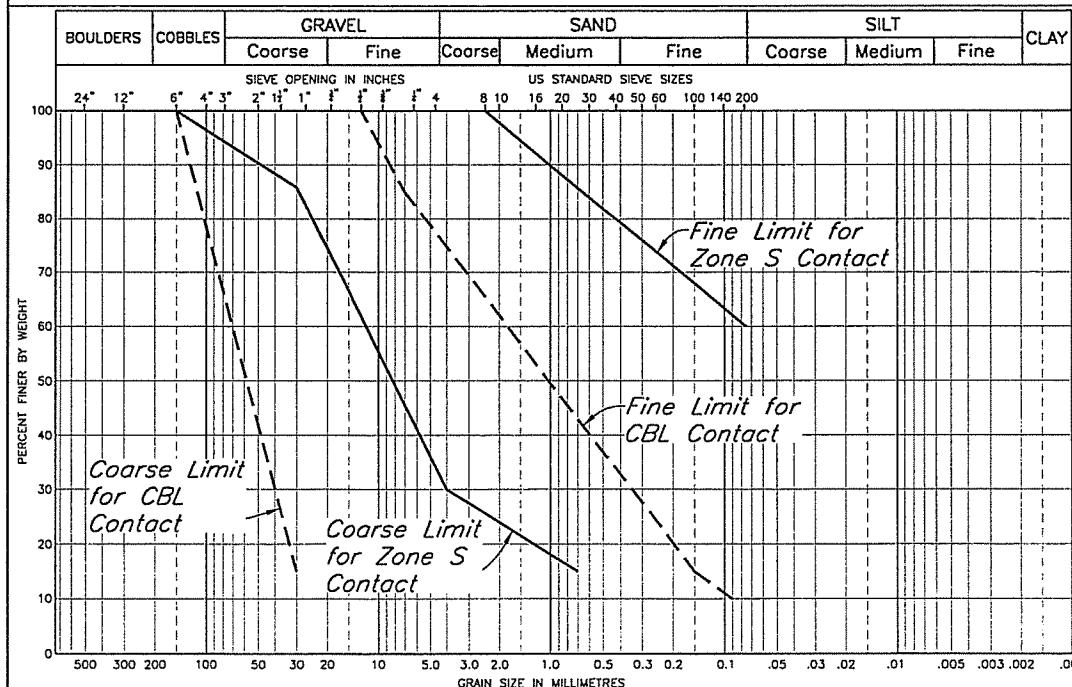

NOT FOR CONSTRUCTION

- DISCLAIMER -

THIS DRAWING WAS PREPARED BY KNIGHT PIESOLD LTD. FOR THE ACCOUNT OF THE CLIENT LISTED ON THIS DRAWING. THE MATERIAL ON IT REFLECTS KNIGHT PIESOLD'S BEST JUDGMENT IN THE LIGHT OF THE INFORMATION AVAILABLE TO IT AT THE TIME OF PREPARATION. ANY USE WHICH A THIRD PARTY MAKES OF THIS DRAWING, OR ANY RELIANCE ON OR DECISIONS TO BE MADE BASED ON IT, ARE THE RESPONSIBILITY OF SUCH THIRD PARTIES. KNIGHT PIESOLD ACCEPTS NO RESPONSIBILITY FOR DAMAGES, IF ANY, SUFFERED BY THE THIRD PARTY AS A RESULT OF DECISIONS MADE OR ACTIONS BASED ON THIS DRAWING. COPIES RESULTING FROM ELECTRONIC TRANSFER OR REPRODUCTION OF THIS DRAWING AND UNCONTROLLED, AND MAY NOT BE THE MOST RECENT REVISION OF THIS DRAWING.

Knicht Piesold
CONSULTING

MOUNT POLLEY MINING CORPORATION

MOUNT POLLEY MINE

TAILINGS STORAGE FACILITY
STAGE 5 TAILINGS EMBANKMENT
MATERIAL SPECIFICATIONS

PROJECT/ASSIGNMENT NO. **VA101-1/12** DRAWING NO. **104** REVISION **0**

| DRG. NO. | DESCRIPTION | REV. | DATE | DESCRIPTION | DESIGN | DRAWN | CHK'D | APP'D |
|----------|---|------|------|-------------|--------|-------|-------|-------|
| 235 | STAGE 5 - SOUTH EMBANKMENT - SECTIONS | | | | | | | |
| 225/226 | STAGE 5 - PERIMETER EMBANKMENT - SECTIONS AND DETAILS | | | | | | | |
| 215/216 | STAGE 5 - MAIN EMBANKMENT - SECTIONS AND DETAILS | | | | | | | |
| 240 | STAGE 5 - SOUTH EMBANKMENT - DRAIN - SECTIONS AND DETAILS | | | | | | | |

| REV. | DATE | DESCRIPTION | DESIGN | DRAWN | CHK'D | APP'D |
|------|----------|-------------------------------|--------|-------|-------|-------|
| 0 | 26MAY'06 | ISSUED FOR STAGE 5 PERMITTING | LJG | TAM | RP | KJB |

REF FILE -

VANCOUVER B.C. CAD FILE: M:\1\01\00001\12\VA\Acad\Drawn\104\104_1-1_Plot_1-1_May 26, 2006 .J

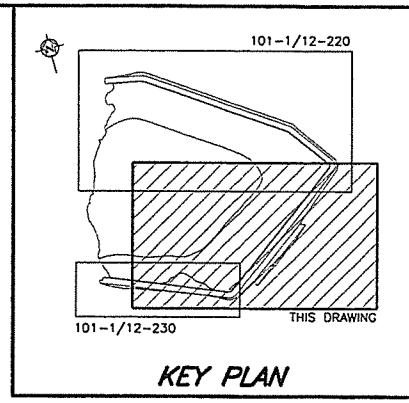
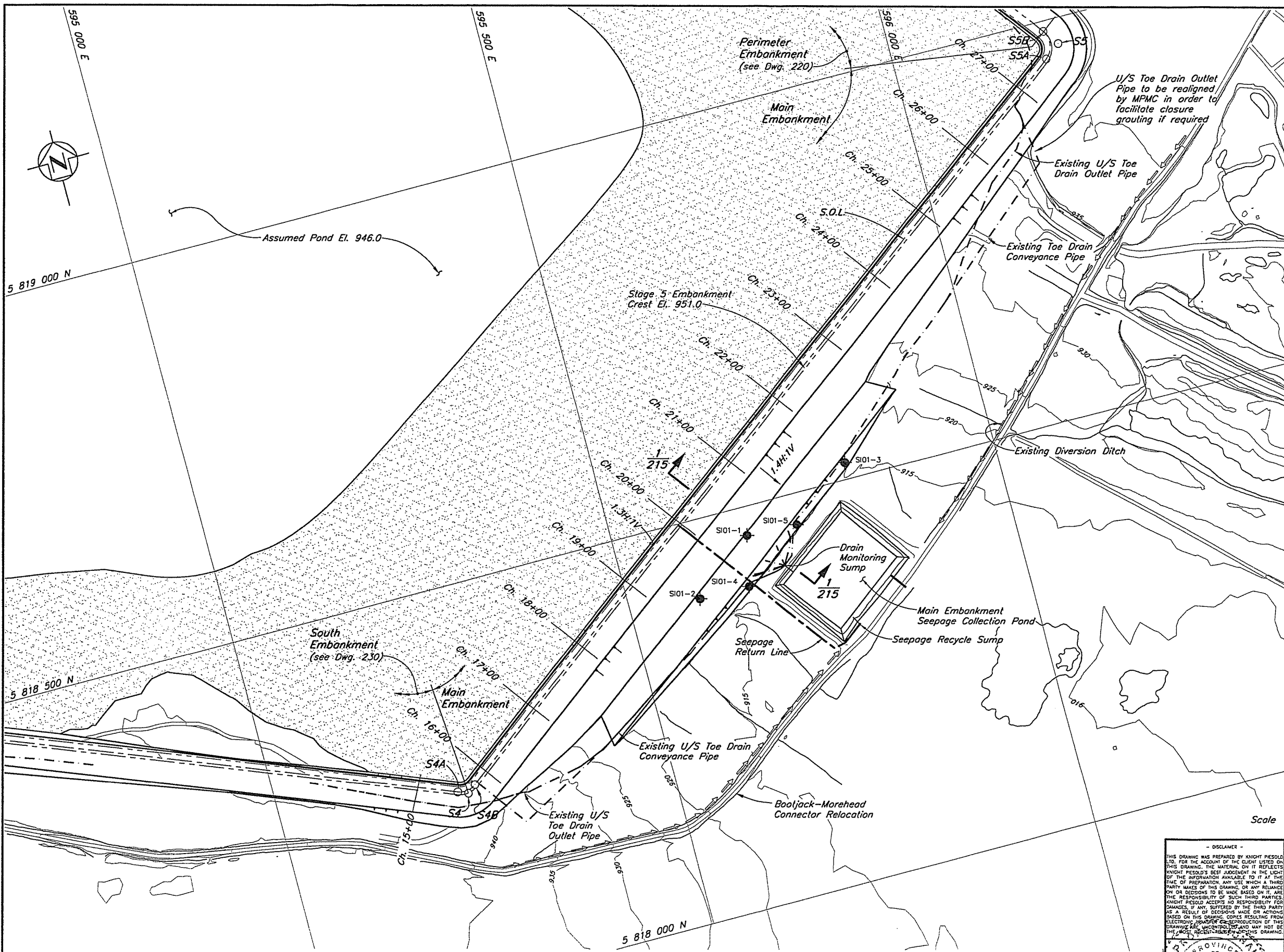

NOT FOR CONSTRUCTION

LEGEND

SI01-3 Existing Inclinator

NOTES

1. Topography from 2004 flyover
2. All dimensions in millimetres and elevations in metres, unless noted otherwise.
3. Stage 5 construction dimensions and volumes assume a Stage 4 crest elevation of El. 948 m.

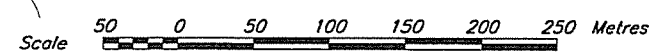

DISCLAIMER
 THIS DRAWING WAS PREPARED BY KNIGHT PIESOLD LTD. FOR THE ACCOUNT OF THE CLIENT LISTED ON THIS DRAWING. THE MATERIAL ON IT REFLECTS KNIGHT PIESOLD'S BEST JUDGEMENT IN THE LIGHT OF THE INFORMATION AVAILABLE TO IT AT THE TIME OF PREPARATION. ANY USE WHICH A THIRD PARTY MAKES OF THIS DRAWING OR ANY RELIANCE ON OR DECISIONS TO BE MADE BASED ON IT, ARE THE RESPONSIBILITY OF SUCH THIRD PARTIES. KNIGHT PIESOLD ACCEPTS NO RESPONSIBILITY FOR DAMAGES, IF ANY, SUFFERED BY THE THIRD PARTY AS A RESULT OF DECISIONS MADE OR ACTIONS BASED ON THIS DRAWING. COPIES RESULTING FROM ELECTRONIC REPRODUCTION OF THIS DRAWING ARE UNCONTROLLED AND MAY NOT BE THE MOST RECENT VERSION OF THIS DRAWING.

L.J. GAMBATH
 2006
 2006

| DRG. NO. | DESCRIPTION | REV. | DATE | DESCRIPTION | DESIGN | DRAWN | CHK'D | APP'D |
|--------------------|--|------|------|-------------|--------|-------|-------|-------|
| 230 | STAGE 5 SOUTH EMBANKMENT - PLAN | | | | | | | |
| 220 | STAGE 5 PERIMETER EMBANKMENT - PLAN | | | | | | | |
| 215 | STAGE 5 MAIN EMBANKMENT - SECTIONS AND DETAILS | | | | | | | |
| REFERENCE DRAWINGS | | | | REVISIONS | | | | |

| REV. | DATE | DESCRIPTION | DESIGN | DRAWN | CHK'D | APP'D |
|-----------|----------|-------------------------------|-----------|-------|-------|-------|
| 0 | 26MAY'06 | ISSUED FOR STAGE 5 PERMITTING | LJG | TAM | BS | ZJS |
| REVISIONS | | | REVISIONS | | | |

Knightsold CONSULTING

MOUNT POLLEY MINING CORPORATION

MOUNT POLLEY MINE

TAILINGS STORAGE FACILITY
 STAGE 5 MAIN EMBANKMENT
 PLAN

PROJECT/ASSIGNMENT NO. VA101-1/12

DRAWING NO. 210

REVISION 0

REF FILE: Topo004, Features

CAD FILE: M:\1\01\00001\12\VA\Acad\Depa\101\210 1-2500 Plot 1-1(P5) June 6 2006 10m VANCOUVER B.C.

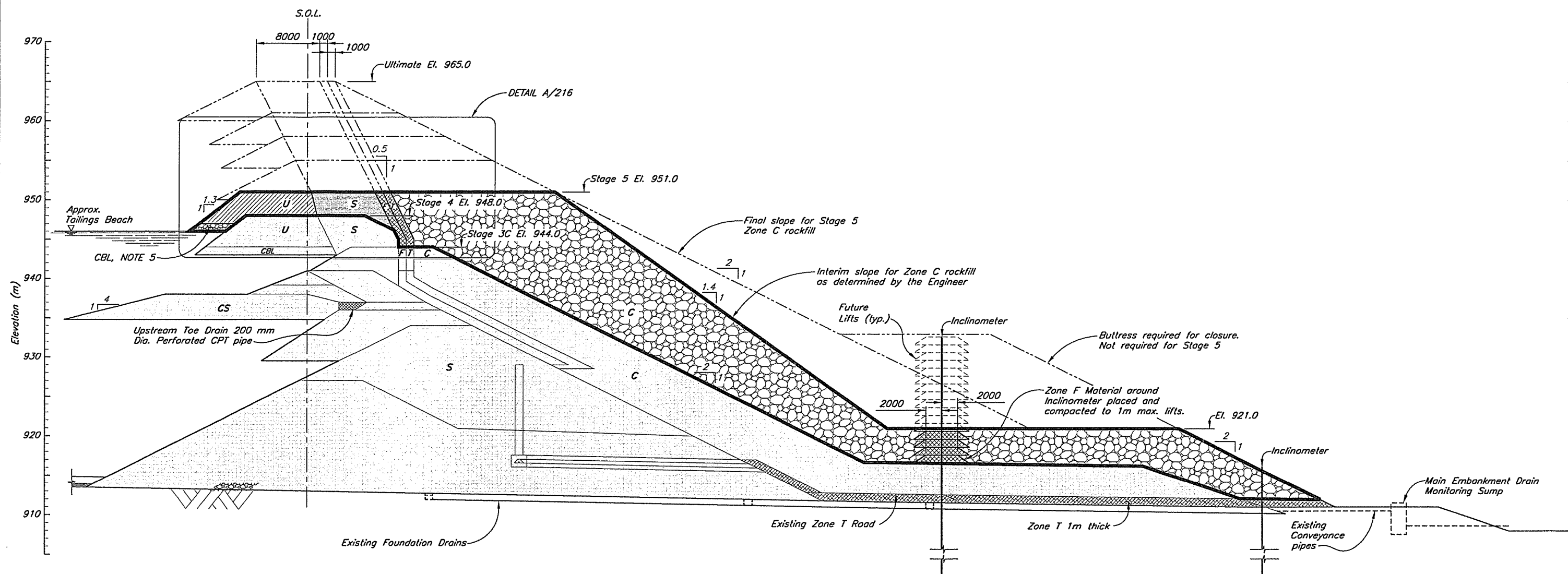

SECTION 1/110

NOTES

1. For zone material specifications and legend see Drg. 104.
2. All dimensions in millimetres and elevations in metres, unless noted otherwise.
3. Minimum lines and grades shown. Lines and grades may be extended upstream and downstream during Stage 5 construction.
4. Drawing is for reference only. IFC drawings will be issued for Stage 5 construction.
5. Coarse bearing layer may be required on tailings beach adjacent to the embankment to create a competent surface for placement on the Zone U material.

NOT FOR CONSTRUCTION

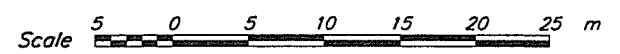

DISCLAIMER
 THIS DRAWING WAS PREPARED BY KNIGHT PIESOLD LTD. FOR THE ACCOUNT OF THE CLIENT LISTED ON THIS DRAWING. THE MATERIAL ON IT REFLECTS KNIGHT PIESOLD'S BEST JUDGEMENT IN THE LIGHT OF THE INFORMATION AVAILABLE TO IT AT THE TIME OF PREPARATION. ANY USE WHICH A THIRD PARTY MAKES OF THIS DRAWING, OR ANY RELIANCE ON OR DECISIONS TO BE MADE BASED ON IT, ARE THE RESPONSIBILITY OF SUCH THIRD PARTIES. KNIGHT PIESOLD ACCEPTS NO RESPONSIBILITY FOR DAMAGES, IF ANY, SUFFERED BY THE THIRD PARTY AS A RESULT OF SUCH USE OR ACTIONS BASED ON THIS DRAWING. COPIES RESULTING FROM ELECTRONIC TRANSFER OR REPRODUCTION OF THIS DRAWING ARE UNCONTROLLED AND MAY NOT BE THE MOST RECENT REVISION OF THIS DRAWING.

L.J. JAL. PAITH
 19/06

Knicht Piésold
 CONSULTING

MOUNT POLLEY MINING CORPORATION

MOUNT POLLEY MINE

TAILINGS STORAGE FACILITY
 STAGE 5 MAIN EMBANKMENT SECTION

PROJECT/ASSIGNMENT NO. VA101-1/12
 DRAWING NO. 215
 REVISION 0

| 210 | STAGE 5 MAIN EMBANKMENT - PLAN |
|--------------------|--------------------------------|
| 104 | MATERIAL SPECIFICATIONS |
| DWG. NO. | DESCRIPTION |
| REFERENCE DRAWINGS | |

| REV. | DATE | DESCRIPTION | DESIGN | DRAWN | CHK'D | APP'D |
|-----------|------|-------------|--------|-------|-------|-------|
| REVISIONS | | | | | | |

| REV. | DATE | DESCRIPTION | DESIGN | DRAWN | CHK'D | APP'D |
|-----------|---------|-------------------------------|--------|-------|-------|-------|
| 0 | 26MAY06 | ISSUED FOR STAGE 5 PERMITTING | LJG | TAM | BS | KJB |
| REVISIONS | | | | | | |

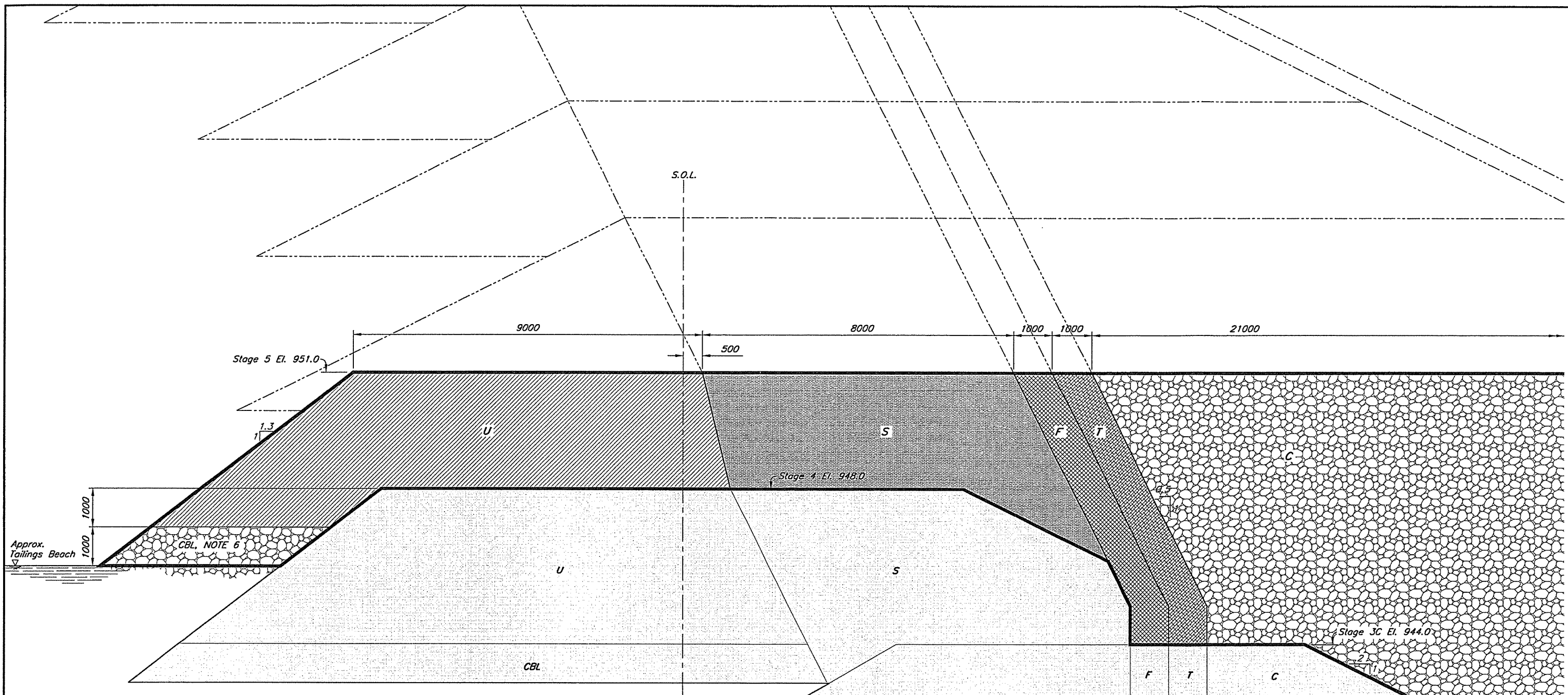

DETAIL A/210

NOT FOR CONSTRUCTION

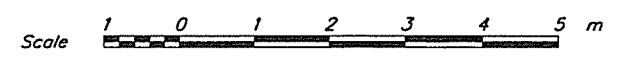

NOTES

1. For zone material specifications and legend see Drg. 104.
2. All dimensions in millimetres and elevations in metres, unless noted otherwise.
3. Zone S to be placed to minimum 8 m width at El. 951. Zone F and Zone T to be placed to a minimum of 1 m width.
4. Minimum lines and grades shown. Lines and grades may be extended upstream and downstream during Stage 5 construction.
5. Stage 5 Zone C Shell to be raised concurrently with Zone S, T and above El. 944.0.
6. Coarse bearing layer may be required on tailings beach adjacent to the embankment to create a competent surface for placement on the Zone U material.
7. Appropriate filter relationships required between all embankment zones and materials as required by the Engineer.

| | |
|--------------------|-------------------------------------|
| 215 | STAGE 5 - MAIN EMBANKMENT - SECTION |
| 210 | STAGE 5 - MAIN EMBANKMENT - PLAN |
| 104 | Stage 5 - MATERIAL SPECIFICATIONS |
| DRG. NO. | DESCRIPTION |
| REFERENCE DRAWINGS | |

| REV. | DATE | DESCRIPTION | DESIGN | DRAWN | CHK'D | APP'D |
|-----------|------|-------------|--------|-------|-------|-------|
| REVISIONS | | | | | | |

| REV. | DATE | DESCRIPTION | DESIGN | DRAWN | CHK'D | APP'D |
|-----------|----------|-------------------------------|--------|-------|-------|-------|
| 0 | 26MAY'06 | ISSUED FOR STAGE 5 PERMITTING | LJG | TAM | RS | RJB |
| REVISIONS | | | | | | |

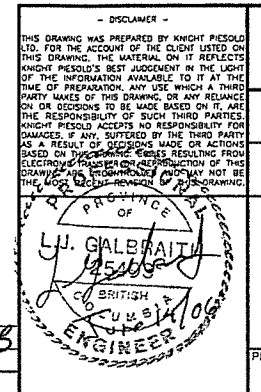

Knight Piésold
CONSULTING

MOUNT POLLEY MINING CORPORATION

MOUNT POLLEY MINE

**TAILINGS STORAGE FACILITY
STAGE 5 MAIN EMBANKMENT
DETAIL**

| | | |
|------------------------|-------------|----------|
| PROJECT/ASSIGNMENT NO. | DRAWING NO. | REVISION |
| VA101-1/12 | 216 | 0 |

CAD FILE: M:\101\00001\1\VA\Lead\Draw\215\215.dwg Plot: 1=1 (PS) June 6 2006 10:50 AM VANCOUVER B.C.

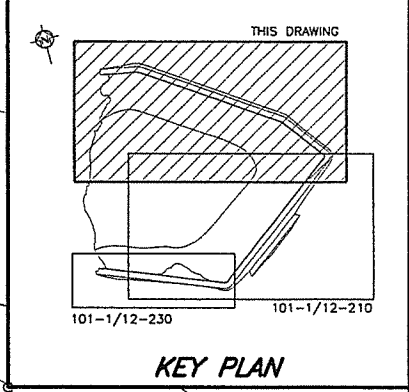
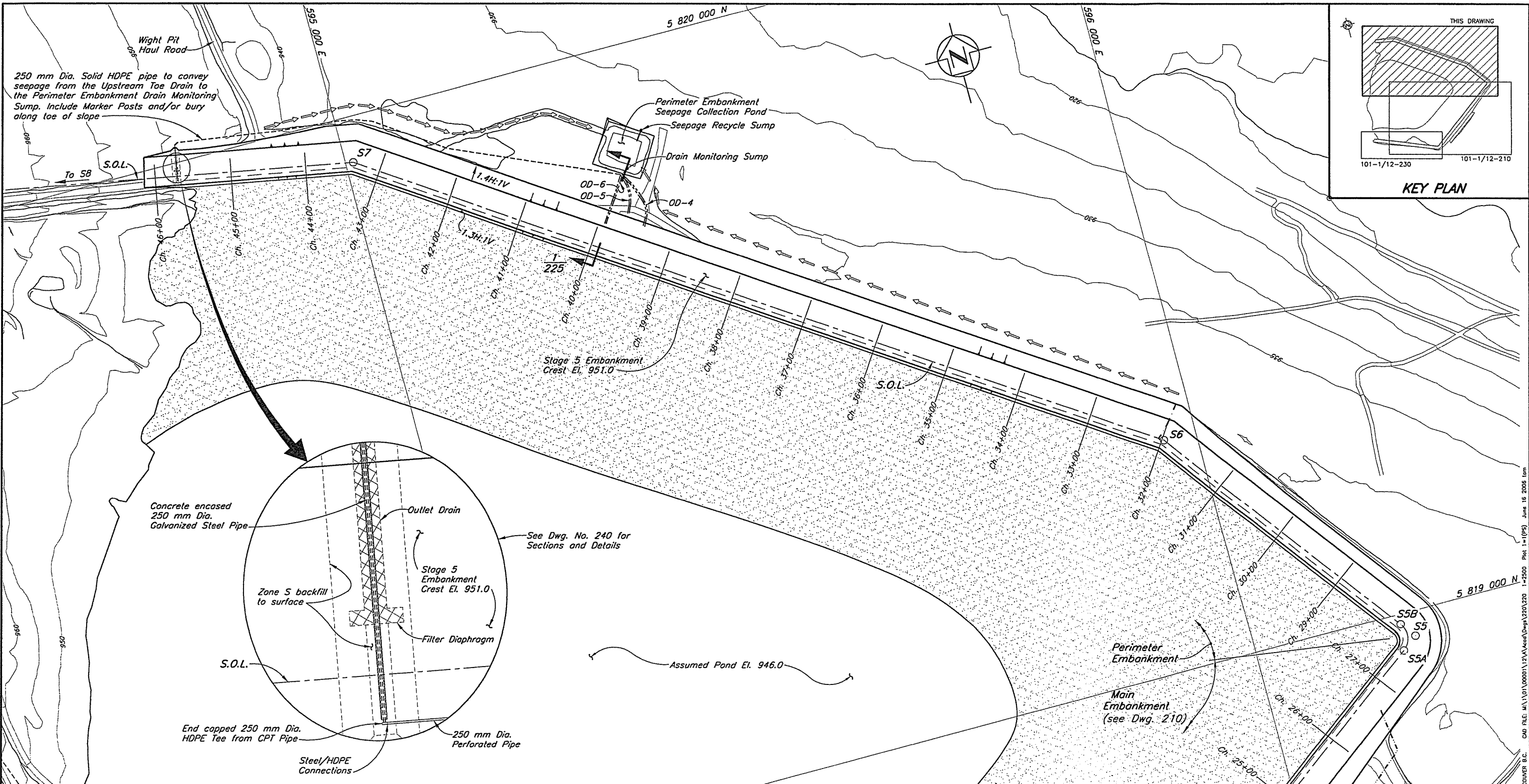

250 mm Dia. Solid HDPE pipe to convey seepage from the Upstream Toe Drain to the Perimeter Embankment Drain Monitoring Sump. Include Marker Posts and/or bury along toe of slope

Concrete encased 250 mm Dia. Galvanized Steel Pipe

Outlet Drain

Stage 5 Embankment Crest El. 951.0

Filter Diaphragm

Zone S backfill to surface

S.O.L.

End capped 250 mm Dia. HDPE Tee from CPT Pipe

250 mm Dia. Perforated Pipe

Steel/HDPE Connections

See Dwg. No. 240 for Sections and Details

Assumed Pond El. 946.0

Perimeter Embankment

Main Embankment (see Dwg. 210)

| EMBANKMENT SETTING OUT POINTS | | | |
|-------------------------------|---------------|-------------|----------|
| Point | Northing | Easting | Chainage |
| S1 | 5 818 626.163 | 594 249.555 | 5+00.00 |
| S4A | 5 818 243.621 | 595 227.361 | 15+49.97 |
| S4B | 5 818 246.923 | 595 251.497 | 15+77.87 |
| S4 | 5 818 238.539 | 595 240.350 | 15+63.92 |
| S5A | 5 818 951.971 | 596 188.906 | 27+50.83 |
| S5B | 5 818 986.958 | 596 193.873 | 28+00.78 |
| S5 | 5 818 986.983 | 596 208.866 | 27+75.80 |
| S6 | 5 819 304.035 | 595 955.881 | 31+97.23 |
| S7 | 5 819 939.748 | 595 010.249 | 43+36.69 |
| S8 | 5 820 053.034 | 594 396.471 | 49+60.83 |

NOTES:

1. Topography from 2004 flyover.
2. All dimensions in millimetres and elevations in metres, unless noted otherwise.
3. Stage 5 construction dimensions and volumes assume a Stage 4 crest elevation of El. 948 m.
4. Concrete encasement to have sloped sides to allow for superior compaction of earthfill materials against it.

NOT FOR CONSTRUCTION

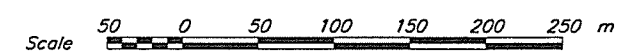

| | |
|--------------------|---|
| 240 | STAGE 5 PERIMETER EMBANKMENT - UPSTREAM TOE DRAIN |
| 230 | STAGE 5 SOUTH EMBANKMENT - PLAN |
| 225 | STAGE 5 PERIMETER EMBANKMENT - SECTIONS |
| 210 | STAGE 5 MAIN EMBANKMENT - PLAN |
| DRG. NO. | DESCRIPTION |
| REFERENCE DRAWINGS | |

| REV. | DATE | DESCRIPTION | DESIGN | DRAWN | CHK'D | APP'D |
|-----------|------|-------------|--------|-------|-------|-------|
| REVISIONS | | | | | | |

| REV. | DATE | DESCRIPTION | DESIGN | DRAWN | CHK'D | APP'D |
|-----------|----------|-------------------------------|--------|-------|-------|-------|
| 0 | 14JUN'06 | ISSUED FOR STAGE 5 PERMITTING | LJG | NSD | RB | KIB |
| REVISIONS | | | | | | |

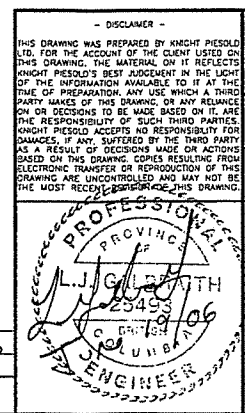

Knight Piésold
CONSULTING

MOUNT POLLEY MINING CORPORATION
MOUNT POLLEY MINE

TAILINGS STORAGE FACILITY
STAGE 5 PERIMETER EMBANKMENT
PLAN

| | | |
|---|---------------------------|----------------------|
| PROJECT/ASSIGNMENT NO. VA101-1/12 | DRAWING NO. 220 | REVISION 0 |
|---|---------------------------|----------------------|

REF FILE : Topo2004

CADD FILE: M:\1\01\00001\12\VA\Knsd\Draws\220\220 1-2500 Plot 1.m (P5) June 16 2006 10m VANCOUVER B.C.

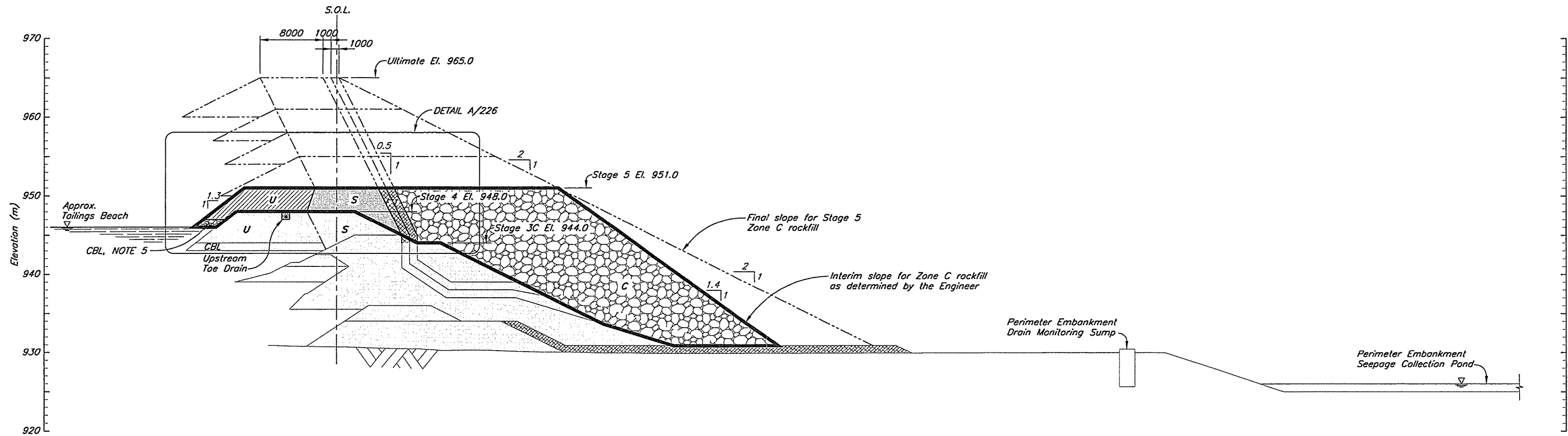

SECTION 1/220

NOTES

1. For zone material specifications and legend see Drg. 104.
2. All dimensions in millimetres and elevations in metres, unless noted otherwise.
3. Minimum lines and grades shown. Lines and grades may be extended upstream and downstream during Stage 5 construction.
4. Drawing is for reference only. IFC drawings will be issued for each stage construction.
5. Coarse bearing layer may be required on tailings beach adjacent to the embankment to create a competent surface for placement on the Zone U material.

NOT FOR CONSTRUCTION

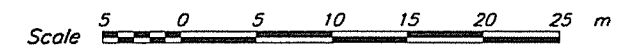

| | |
|--------------------|---|
| 226 | STAGE 5 - PERIMETER EMBANKMENT - DETAIL |
| 220 | STAGE 5 - PERIMETER EMBANKMENT - PLAN |
| 104 | STAGE 5 - MATERIAL SPECIFICATIONS |
| DRG. NO. | DESCRIPTION |
| REFERENCE DRAWINGS | |

| REV. | DATE | DESCRIPTION | DESIGN | DRAWN | CHK'D | APP'D |
|-----------|------|-------------|--------|-------|-------|-------|
| REVISIONS | | | | | | |

| REV. | DATE | DESCRIPTION | DESIGN | DRAWN | CHK'D | APP'D |
|-----------|----------|-------------------------------|--------|-------|-------|-------|
| 0 | 26MAY'06 | ISSUED FOR STAGE 5 PERMITTING | LJG | TAM | BB | ZJB |
| REVISIONS | | | | | | |

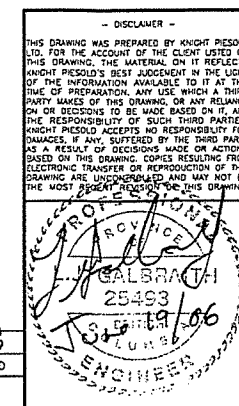

| | | |
|--|-------------|----------|
| Knicht Piesold CONSULTING | | |
| MOUNT POLLEY MINING CORPORATION | | |
| MOUNT POLLEY MINE | | |
| TAILINGS STORAGE FACILITY STAGE 5 - PERIMETER EMBANKMENT SECTION | | |
| PROJECT/ASSIGNMENT NO. | DRAWING NO. | REVISION |
| VA101-1/12 | 225 | 0 |

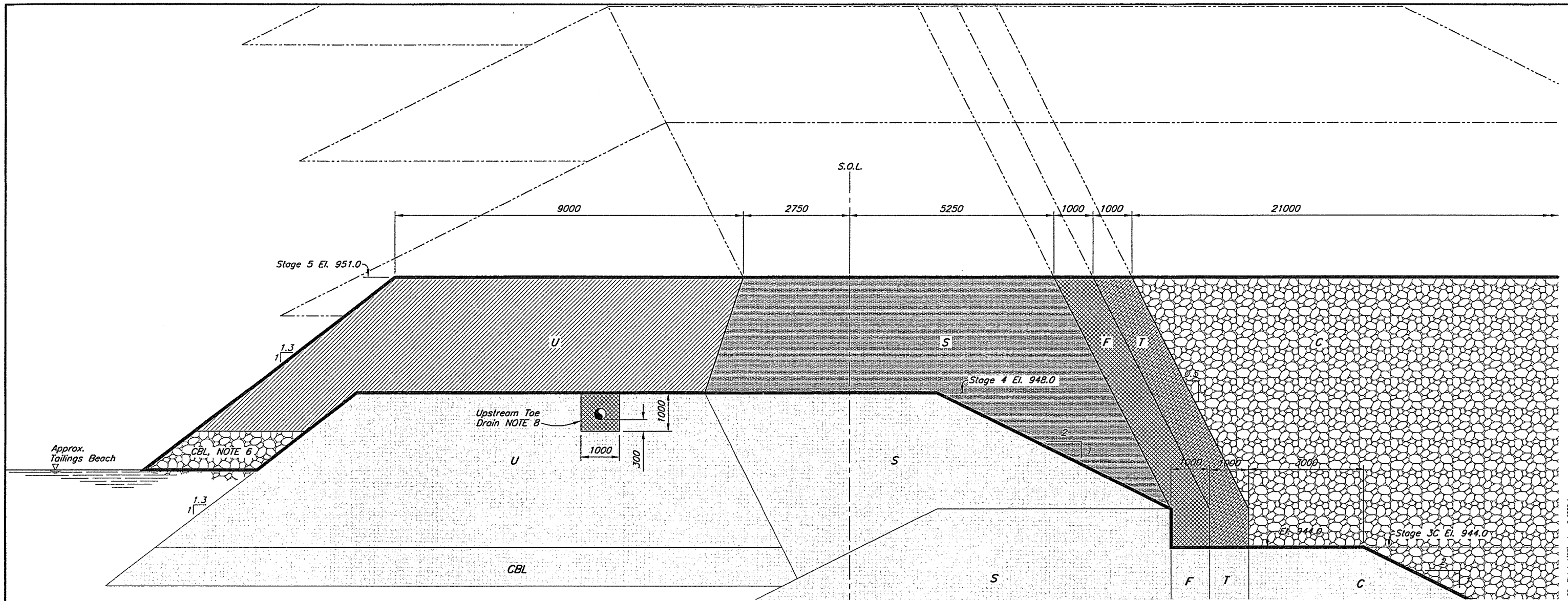

DETAIL A
Scale B

NOTES:

1. For zone material specifications and legend see Drg. 104.
2. All dimensions in millimetres and elevations in metres, unless noted otherwise.
3. Zone S to be placed to minimum 8 m width at El. 951.
4. Minimum lines and grades shown. Lines and grades may be extended upstream and downstream during Stage 5 construction.
5. Stage 5 construction dimensions and volumes assume a Stage 4 crest elevation of EL 948.0.
6. Coarse bearing layer may be required on tailings beach adjacent to the embankment to create a competent surface for placement on the Zone U material.
7. Stage 5 Zone C Shell to be raised concurrently with Zones S, T, and F above El. 944.0
8. Upstream Toe Drain Zone F material to have a filter relationship with surrounding Zone U.

NOT FOR CONSTRUCTION

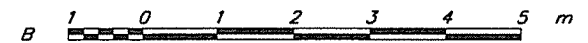

NOT FOR CONSTRUCTION

| | |
|----------|--|
| 225 | STAGE 5 - PERIMETER EMBANKMENT - SECTION |
| 220 | STAGE 5 - PERIMETER EMBANKMENT - PLAN |
| 104 | STAGE 5 - MATERIAL SPECIFICATIONS |
| DRG. NO. | DESCRIPTION |
| | REFERENCE DRAWINGS |

| REV. | DATE | DESCRIPTION | DESIGN | DRAWN | CHK'D | APP'D |
|------|------|-------------|--------|-------|-------|-------|
| | | | | | | |

| REV. | DATE | DESCRIPTION | DESIGN | DRAWN | CHK'D | APP'D |
|------|----------|-------------------------------|--------|-------|-------|-------|
| 0 | 26MAY'06 | ISSUED FOR STAGE 5 PERMITTING | LJG | TAM | BS | PIS |
| | | | | | | |

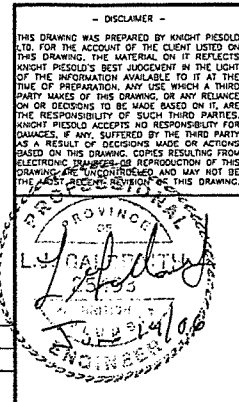

Knicht Piésold
CONSULTING

MOUNT POLLEY MINING CORPORATION

MOUNT POLLEY MINE

TAILINGS STORAGE FACILITY
STAGE 5 PERIMETER EMBANKMENT
DETAIL

| | | |
|------------------------|-------------|----------|
| PROJECT/ASSIGNMENT NO. | DRAWING NO. | REVISION |
| VA101-1/12 | 226 | 0 |

XREF FILE :

C:\D:\FILE\M\1\01\0000\1\2\VA\kcp\06\06\226\226 1-50 Plot 1-105 June 6 2006 lam

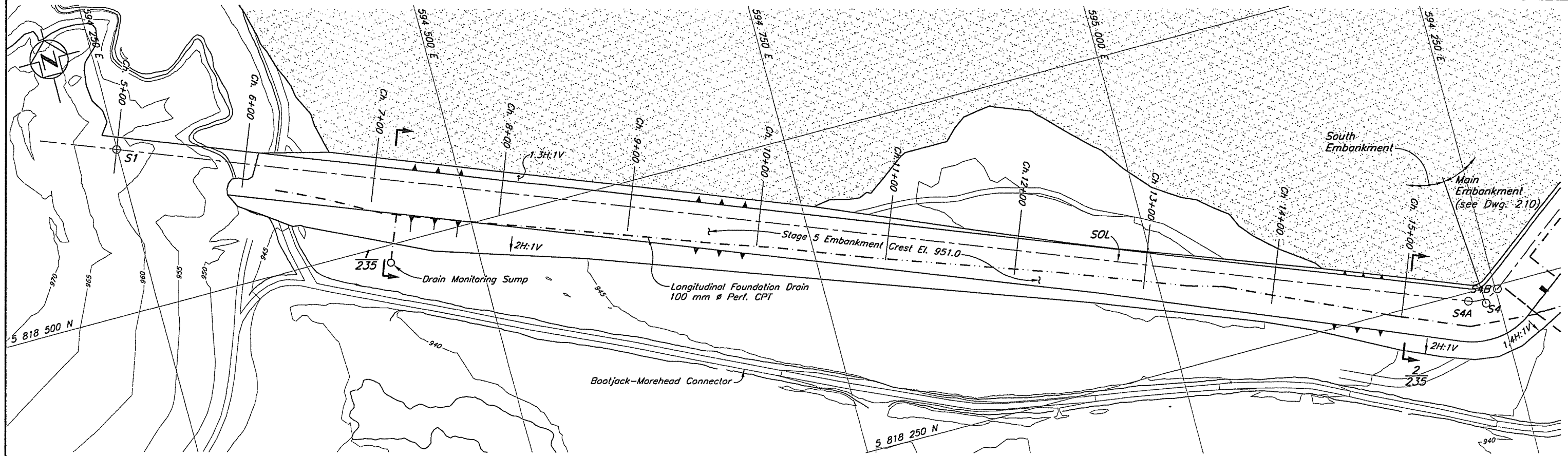
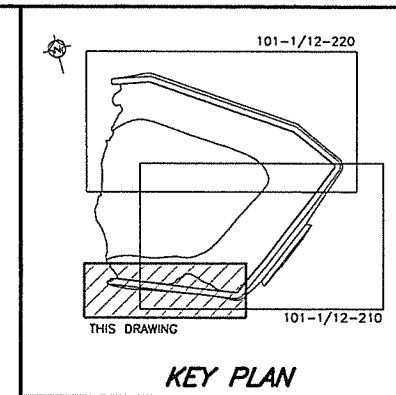

PLAN

NOT FOR CONSTRUCTION

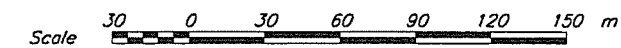

NOTES

1. Topography from 2004 flyover.
2. All dimensions in millimetres and elevations in metres, unless noted otherwise.
3. Stage 5 construction dimensions and volumes assume a Stage 4 crest elevation of El. 948 m.

| DRG. NO. | DESCRIPTION |
|----------|---|
| 235 | STAGE 5 SOUTH EMBANKMENT - SECTIONS |
| 220 | STAGE 5 PERIMETER EMBANKMENT - PLAN |
| 210 | STAGE 5 MAIN EMBANKMENT - PLAN |
| 104 | STAGE 5 TAILINGS EMBANKMENT - MATERIAL SPECIFICATIONS |

| REV. | DATE | DESCRIPTION | DESIGN | DRAWN | CHK'D | APP'D |
|------|------|-------------|--------|-------|-------|-------|
| | | | | | | |

| REV. | DATE | DESCRIPTION | DESIGN | DRAWN | CHK'D | APP'D |
|------|----------|-------------------------------|--------|-------|-------|-------|
| 0 | 26MAY'06 | ISSUED FOR STAGE 5 PERMITTING | LJG | TAM | BB | KIB |

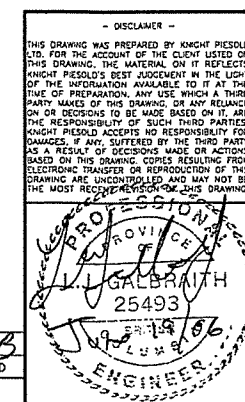

Knicht Piésold
CONSULTING

MOUNT POLLEY MINE CORPORATION
MOUNT POLLEY MINE
TAILINGS STORAGE FACILITY
STAGE 5 SOUTH EMBANKMENT
PLAN

| | | |
|------------------------|-------------|----------|
| PROJECT/ASSIGNMENT NO. | DRAWING NO. | REVISION |
| VA101-1/12 | 230 | 0 |

REF. FILE :

C:\D:\FILE\101\09000\1\2\1\A\Head\Draw\230\230 1-1500 - Plot 1-1 (P5) June 19 2006 10:58 AM

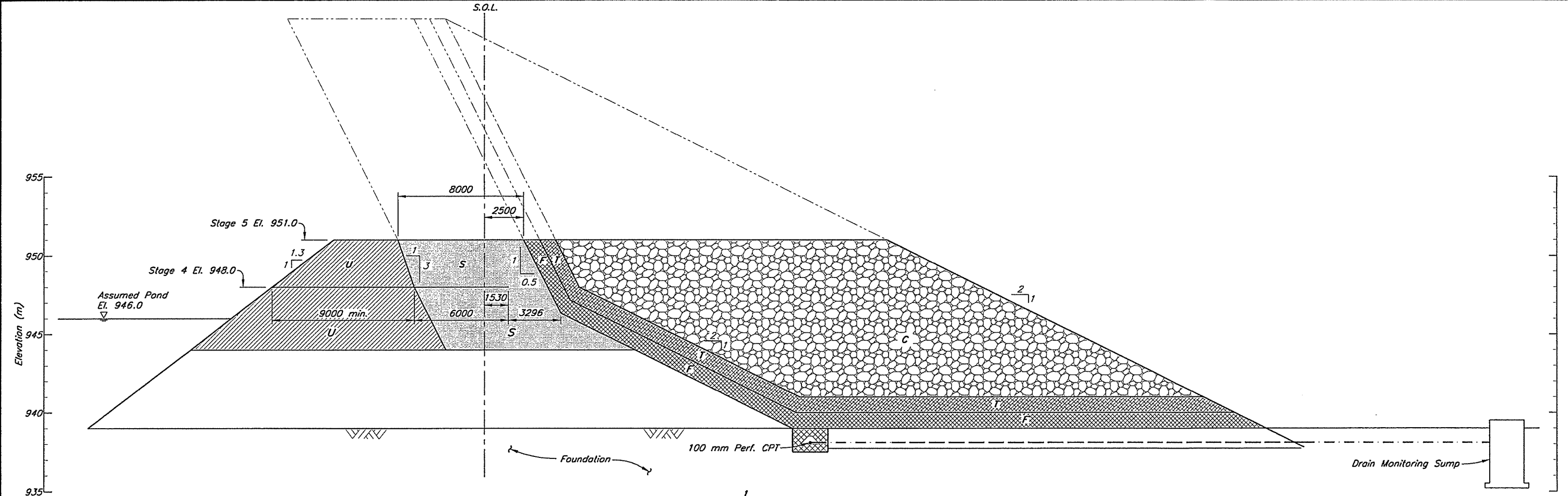

SECTION $\frac{1}{230}$
Scale A

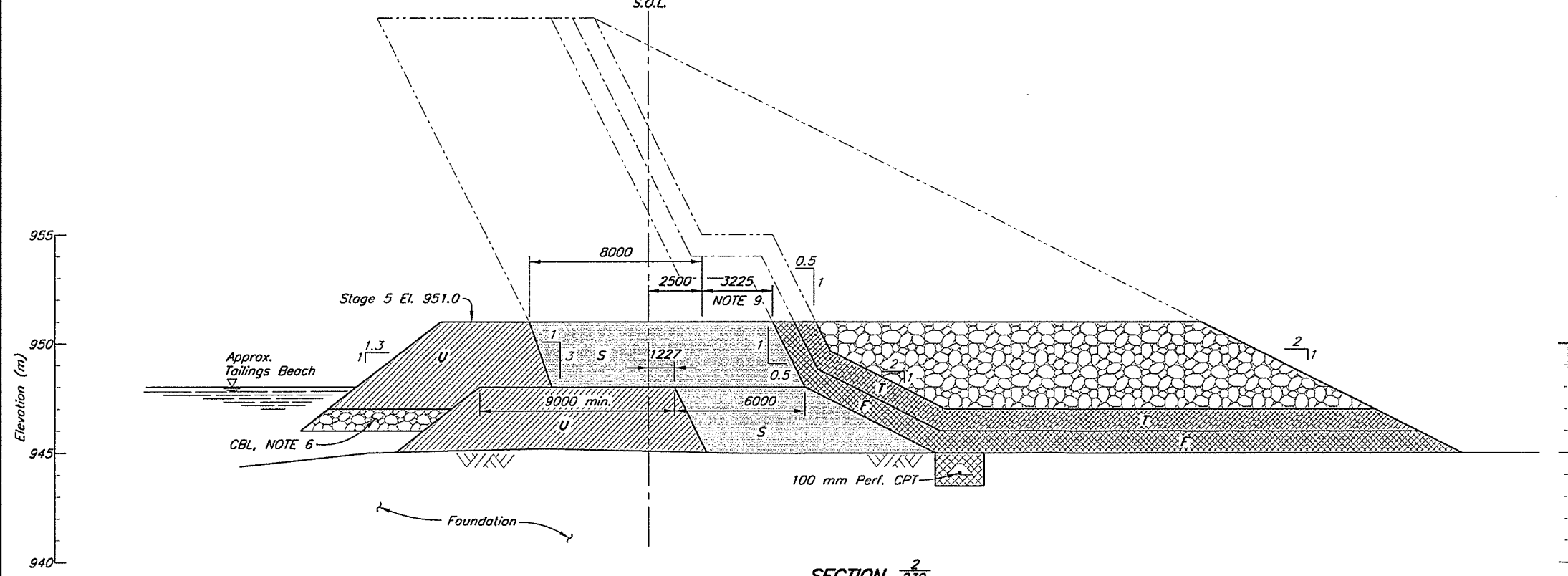

SECTION $\frac{2}{230}$
Scale A

NOTES

1. For zone material specifications and legend see Drg. 104.
2. All dimensions in millimetres and elevations in metres, unless noted otherwise.
3. Zone S to be placed to minimum 8 m width at El. 948.
4. Minimum lines and grades shown. Lines and grades may be extended upstream and downstream during Stage 5 construction.
5. Stage 5 construction dimensions and volumes assume a Stage 4 crest elevation of El. 948 m.
6. Coarse bearing layer may be required on tailings beach adjacent to the embankment to create a competent surface for placement on the Zone U material.
7. Subgrade preparation to comprise stripping of topsoil and organics, removing saturated materials and proof rolling to establish a competent, bearing surface for fill placement as directed by the Engineer.
8. Appropriate filter relationships required between all embankment zones and materials as required by the Engineer.
9. Maximum dimension of 3225 at Ch. 15+00 and gradually decreases to 0 at Ch. 13+50

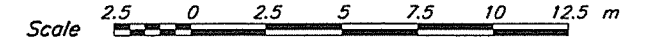

DISCLAIMER
THIS DRAWING WAS PREPARED BY KNIGHT PIESOLD LTD. FOR THE ACCOUNT OF THE CLIENT LISTED ON THIS DRAWING. THE MATERIAL ON IT REFLECTS KNIGHT PIESOLD'S BEST JUDGMENT IN THE LIGHT OF THE INFORMATION AVAILABLE TO IT AT THE TIME OF PREPARATION. ANY USE WHICH A THIRD PARTY MAKES OF THIS DRAWING, OR ANY RELIANCE ON OR DECISIONS TO BE MADE BASED ON IT, ARE THE RESPONSIBILITY OF SUCH THIRD PARTIES. KNIGHT PIESOLD ACCEPTS NO RESPONSIBILITY FOR DAMAGES, IF ANY, SUFFERED BY THE THIRD PARTY AS A RESULT OF DECISIONS MADE OR ACTIONS BASED ON THIS DRAWING. COPIES RESULTING FROM ELECTRONIC TRANSFER OR REPRODUCTION OF THIS DRAWING ARE UNCONTROLLED AND MAY NOT BE THE MOST RECENT REVISION OF THIS DRAWING.

Knicht Piesold
CONSULTING

MOUNT POLLEY MINING CORPORATION

MOUNT POLLEY MINE

TAILINGS STORAGE FACILITY
STAGE 5 SOUTH EMBANKMENT
SECTIONS

PROJECT/ASSIGNMENT NO. VA101-1/12 DRAWING NO. 235 REVISION 0

NOT FOR CONSTRUCTION

| 236 | STAGE 5 SOUTH EMBANKMENT - SECTIONS & DETAILS |
|----------|---|
| 230 | STAGE 5 SOUTH EMBANKMENT - PLAN |
| 104 | STAGE 5 TAILINGS EMBANKMENT - MATERIAL SPECIFICATIONS |
| DRG. NO. | DESCRIPTION |

| REV. | DATE | DESCRIPTION | DESIGN | DRAWN | CHK'D | APP'D |
|-----------|------|-------------|--------|-------|-------|-------|
| REVISIONS | | | | | | |

| REV. | DATE | DESCRIPTION | DESIGN | DRAWN | CHK'D | APP'D |
|-----------|----------|-------------------------------|--------|-------|-------|-------|
| 0 | 26MAY'06 | ISSUED FOR STAGE 5 PERMITTING | LJG | TAM | BB | KLB |
| REVISIONS | | | | | | |

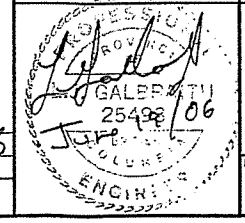

WACOUVER B.C. CAD FILE: H:\1\01\0606\1\2\VA\cases\06\06\235\235.dwg 1=125 Plot: 1=1[PS] June 15 2006 6:00

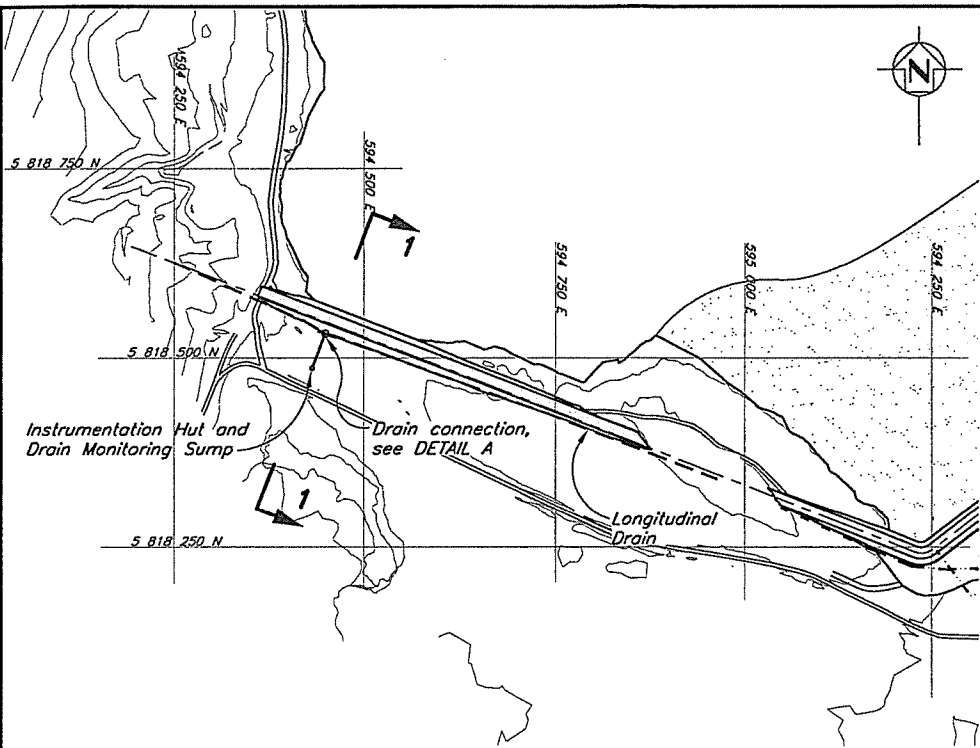

SOUTH EMBANKMENT PLAN
Scale A

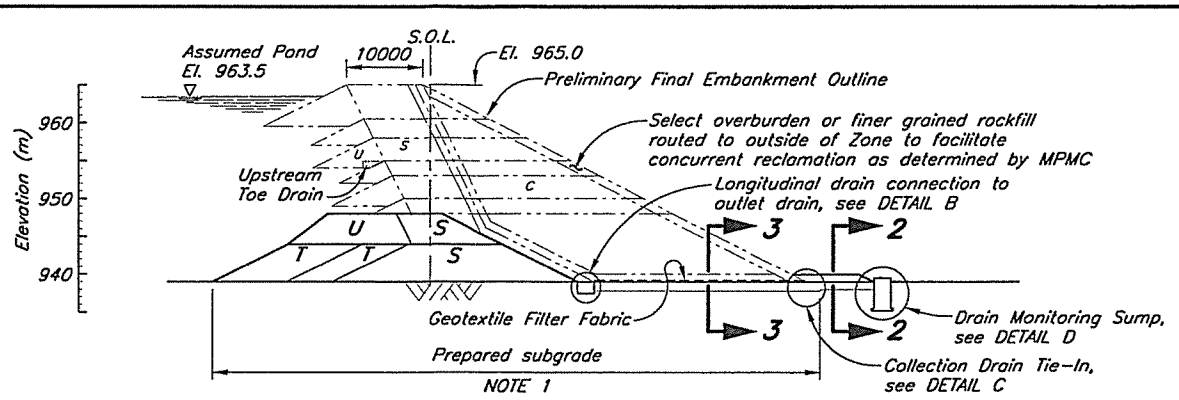

SECTION 1
Scale B

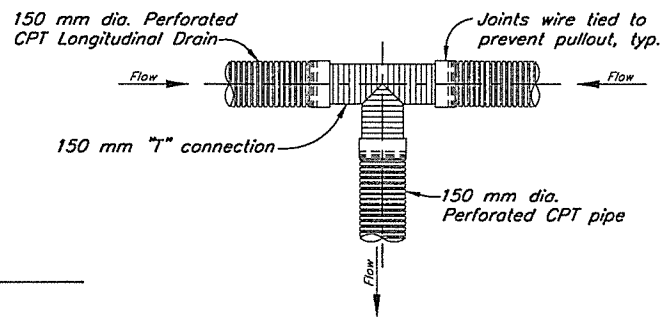

DETAIL A
TYPICAL LONGITUDINAL DRAIN TO OUTLET DRAIN CONNECTION
NTS

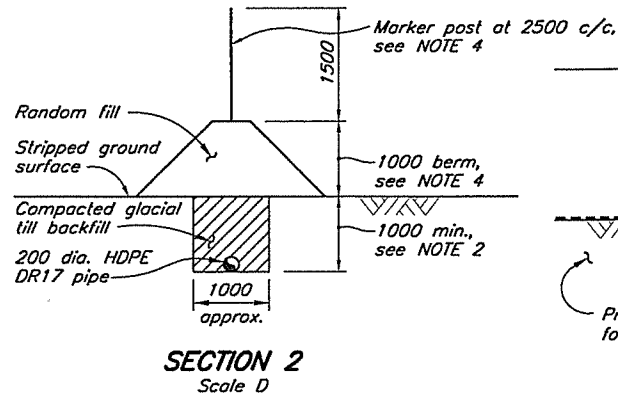

SECTION 2
Scale D

- NOTES**
1. Subgrade preparation to comprise stripping of topsoil and organics, removing saturated materials and proof rolling to establish a competent, bearing surface for fill placement as directed by the Engineer.
 2. All pipework to have a minimum of 1 m of cover for frost protection.
 3. All HDPE pipe penetrations to be water tight.
 4. Buried pipework to be covered by a berm and clearly marked by a line of stakes.
 5. Drain Monitoring Sump is conceptual only. Details to be provided in the Stage 4 design of the TSF. Details to be designed.
 6. For Zone material specifications and legend, see Dwg. 104.
 7. The Zone D and non-woven geotextile may be replaced with Zone F material that has a suitable filter relationship with the foundation materials and the pipe openings, as approved by the Engineer.

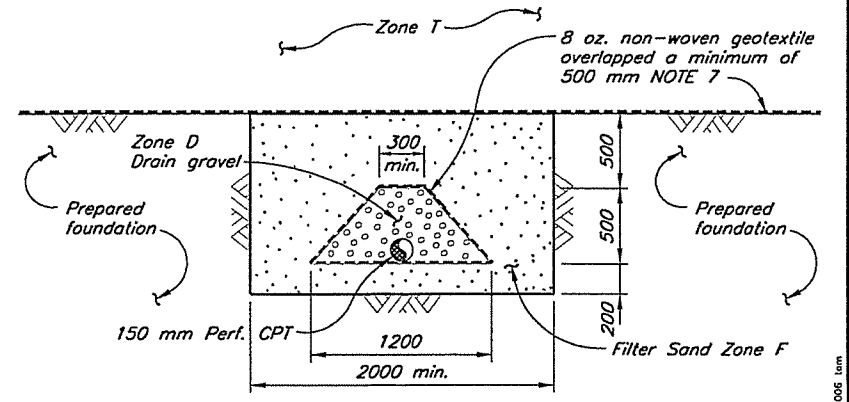

SECTION 3
Scale C

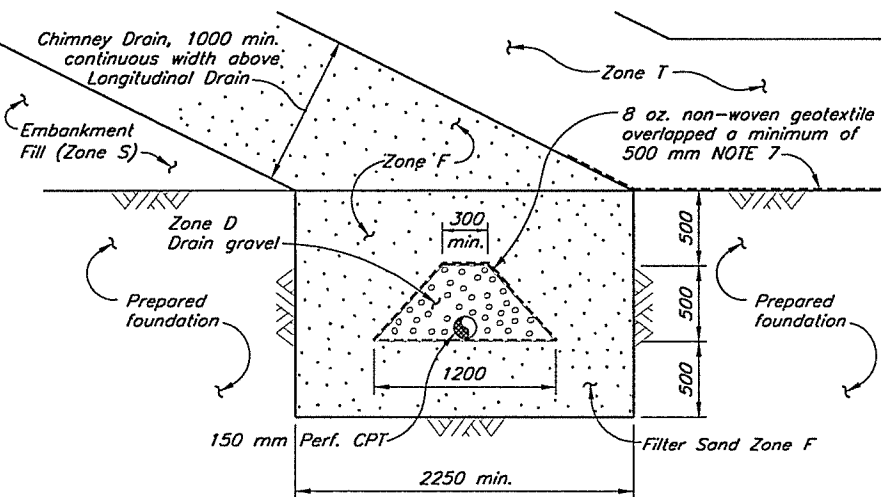

DETAIL B
LONGITUDINAL DRAIN
Scale C

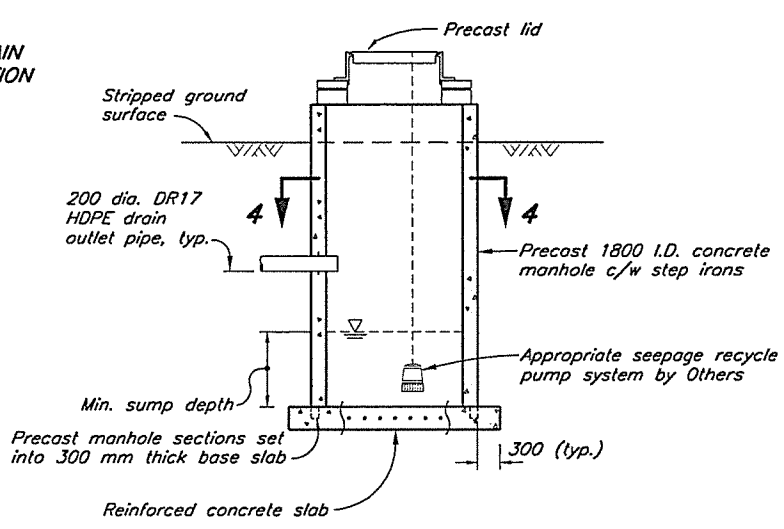

DETAIL D
DRAIN MONITORING SUMP
Scale D

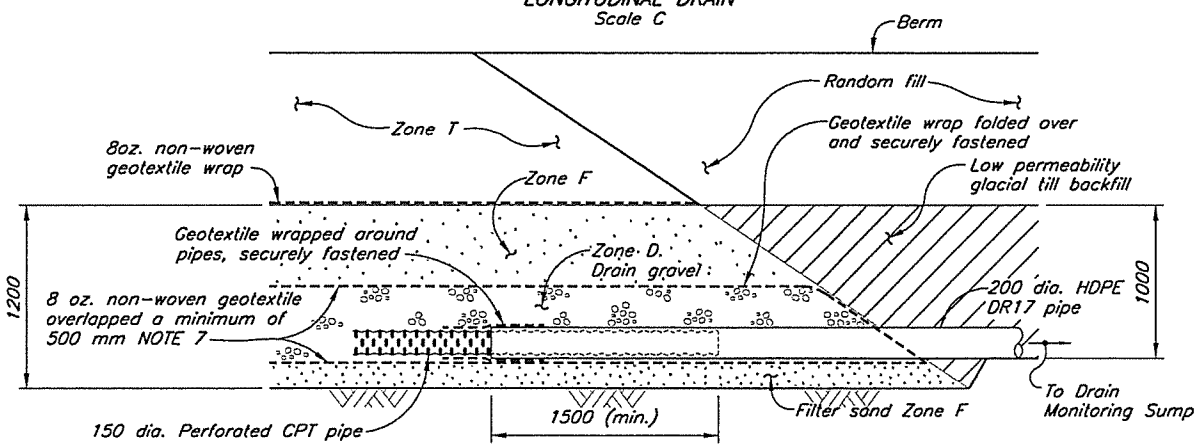

DETAIL C
COLLECTION DRAIN TIE-IN
Scale C

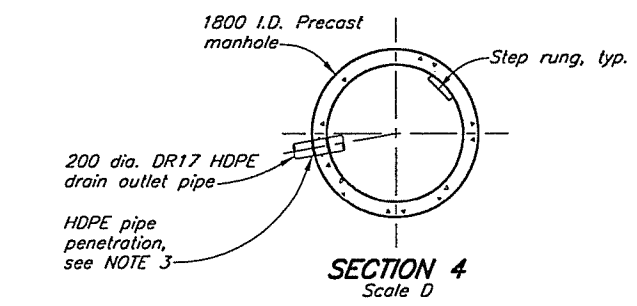
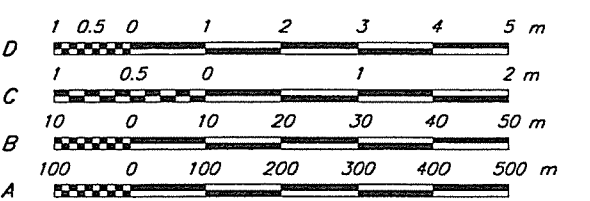

SECTION 4
Scale D

KNIGHT PIESOLD CONSULTING

MOUNT POLLEY MINING CORPORATION

MOUNT POLLEY MINE

TAILINGS STORAGE FACILITY
STAGE 5 – SOUTH EMBANKMENT
LONGITUDINAL AND FOUNDATION DRAIN
SECTIONS AND DETAILS

PROJECT/ASSIGNMENT NO. **VA101-1/12** DRAWING NO. **236** REVISION **0**

DISCLAIMER
THIS DRAWING WAS PREPARED BY KNIGHT PIESOLD LTD. FOR THE ACCOUNT OF THE CLIENT LISTED ON THIS DRAWING. THE MATERIAL ON IT REFLECTS KNIGHT PIESOLD'S BEST JUDGEMENT IN THE LIGHT OF THE INFORMATION AVAILABLE TO IT AT THE TIME OF PREPARATION. ANY USE WHICH A THIRD PARTY MAKES OF THIS DRAWING OR ANY DECISIONS OR ACTIONS TO BE MADE BASED ON IT ARE THE RESPONSIBILITY OF SUCH THIRD PARTIES. KNIGHT PIESOLD ACCEPTS NO RESPONSIBILITY FOR DAMAGES, IF ANY, SUFFERED BY THE THIRD PARTY AS A RESULT OF DECISIONS MADE OR ACTIONS BASED ON THIS DRAWING. COPIES RESULTING FROM ELECTRONIC TRANSFER OR REPRODUCTION OF THIS DRAWING ARE UNCONTROLLED AND MAY NOT BE THE MOST RECENT REVISION OF THIS DRAWING.

PROFESSIONAL ENGINEER
J. J. BAILEY
25493
LUMB

| 104 | ULTIMATE TAILINGS EMBANKMENT – MATERIAL SPECIFICATIONS |
|--------------------|--|
| DRG. NO. | DESCRIPTION |
| REFERENCE DRAWINGS | |

| 0 | 13MAY05 | ISSUED FOR STAGE 4 CONSTRUCTION | AT | ND | BB | LB |
|-----------|---------|---------------------------------|--------|-------|-------|-------|
| REV. | DATE | DESCRIPTION | DESIGN | DRAWN | CHK'D | APP'D |
| REVISIONS | | | | | | |

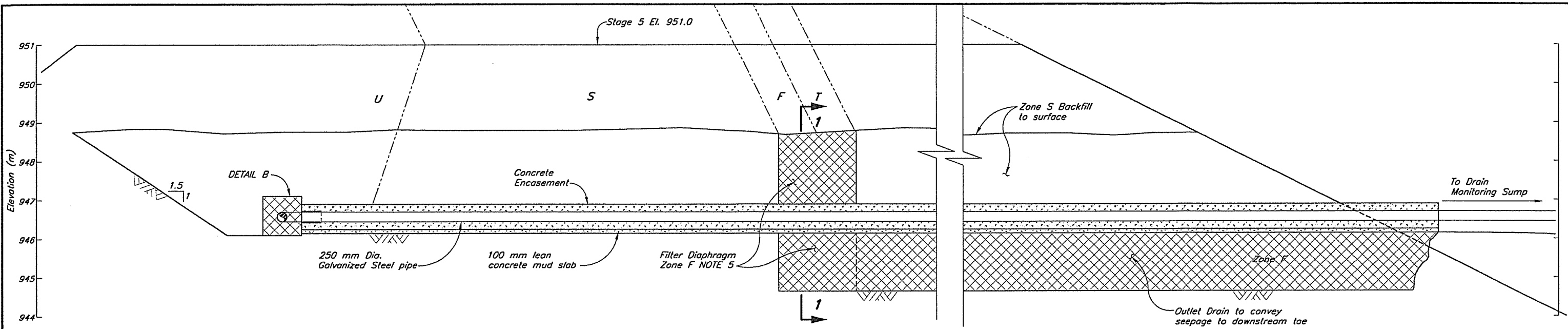

TYPICAL SECTION OF UPSTREAM TOE DRAIN AT ABUTMENTS
Scale A

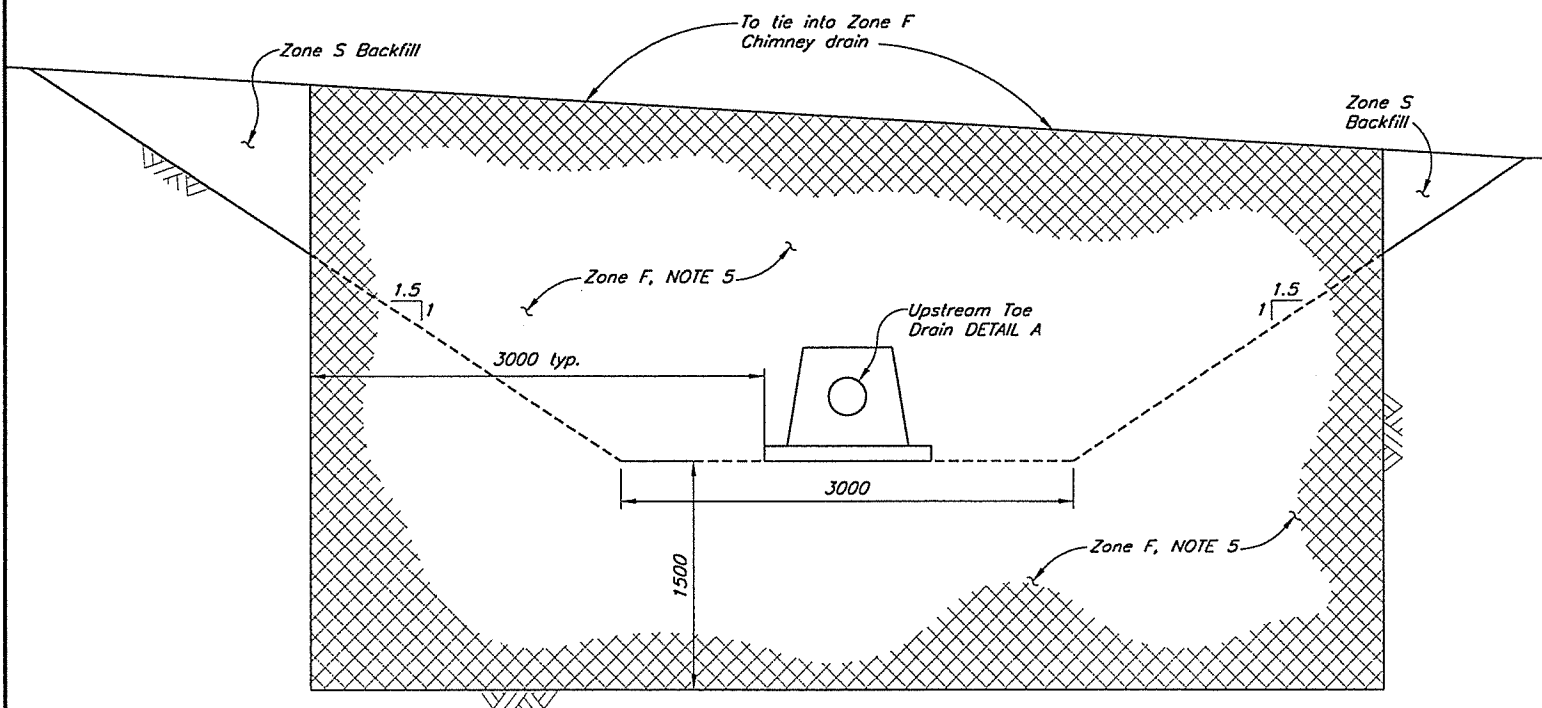

SECTION 1 - FILTER DIAPHRAGM
Scale C

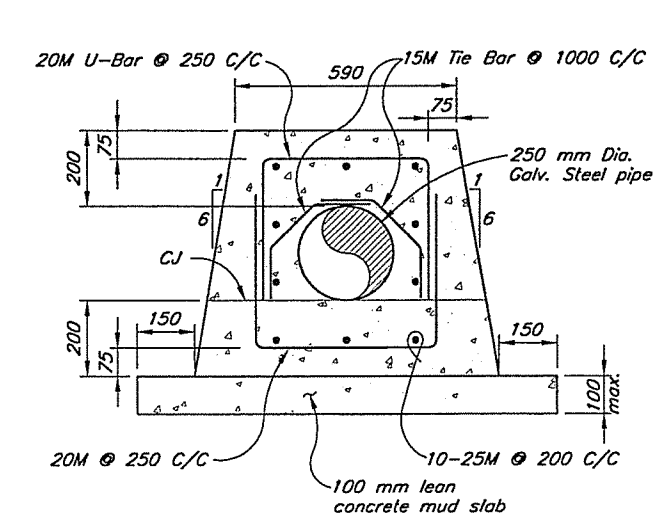

DETAIL A
CONCRETE ENCASEMENT REINFORCEMENT DETAILS
Scale B

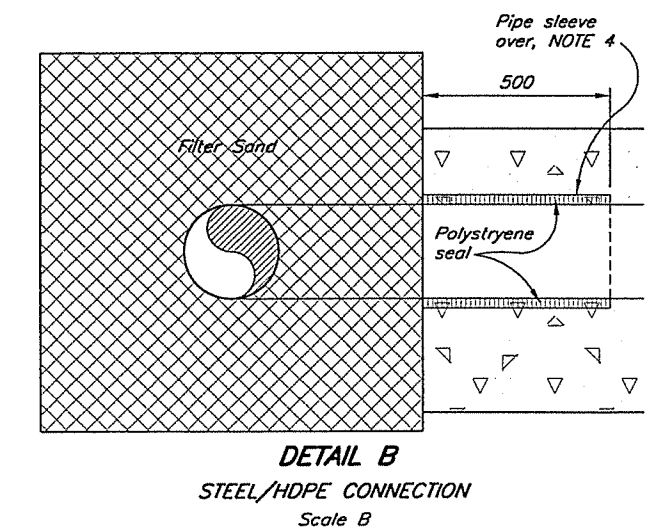

DETAIL B
STEEL/HDPE CONNECTION
Scale B

NOT FOR CONSTRUCTION

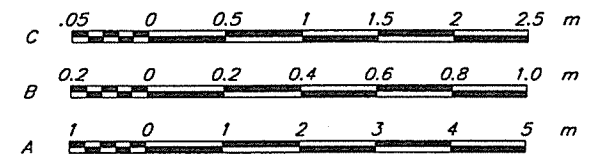

- NOTES:
- Concrete strength: Type C30-20 (30 MPa with 20 mm cover aggregate).
 - Minimum concrete cover 40mm.
 - Reinforcement steel to CSA G30.18 Grade 400R.
 - Sleeve to have an I.D. of 300 mm with the annulus sealed with polystyrene to prevent Filter Sand and/or Concrete from entering.
 - Zone F to be placed and spread in maximum 300 mm thick layers and compacted as approved by the Engineer.

DISCLAIMER
THIS DRAWING WAS PREPARED BY KNIGHT PIESOLD LTD. FOR THE ACCOUNT OF THE CLIENT LISTED ON THIS DRAWING. THE MATERIAL ON IT REFLECTS KNIGHT PIESOLD'S BEST JUDGEMENT IN THE LIGHT OF THE INFORMATION AVAILABLE TO IT AT THE TIME OF PREPARATION. ANY USE WHICH A THIRD PARTY MAKES OF THIS DRAWING OR ANY RELIANCE ON OR DECISIONS TO BE MADE BASED ON IT, ARE THE RESPONSIBILITY OF SUCH THIRD PARTIES. KNIGHT PIESOLD ACCEPTS NO RESPONSIBILITY FOR DAMAGES, IF ANY, SUFFERED BY THE THIRD PARTY AS A RESULT OF DECISIONS MADE OR ACTIONS BASED ON THIS DRAWING. COPIES RESULTING FROM ELECTRONIC TRANSFER OR REPRODUCTION OF THIS DRAWING ARE UNCONTROLLED AND MAY NOT BE THE MOST RECENT REVISION OF THIS DRAWING.

25493
2006
ENGINEER

Knights Piesold CONSULTING

MOUNT POLLEY MINING CORPORATION

MOUNT POLLEY MINE

TAILINGS STORAGE FACILITY

STAGE 5 - PERIMETER EMBANKMENT

UPSTREAM TOE DRAIN

SECTIONS AND DETAILS

PROJECT/ASSIGNMENT NO. **VA101-1/12** DRAWING NO. **240** REVISION **0**

| | |
|----------|--|
| 220 | STAGE 5 PERIMETER EMBANKMENT - PLAN |
| 125 | ULTIMATE PERIMETER EMBANKMENT - SECTIONS |
| 120 | ULTIMATE PERIMETER EMBANKMENT - PLAN |
| DRG. NO. | DESCRIPTION |
| | REVISIONS |

| | | | | | | |
|------|---------|-------------------------------|--------|-------|-------|-------|
| 0 | 14UN'06 | ISSUED FOR STAGE 5 PERMITTING | LJC | TAM | BB | KJB |
| REV. | DATE | DESCRIPTION | DESIGN | DRAWN | CHK'D | APP'D |
| | | REVISIONS | | | | |

SEE FILE -

VA101-1/12-000001\2\A\Case\Draw\240\240 1-50 Plot 1-1[PS] June 15, 2006 tem

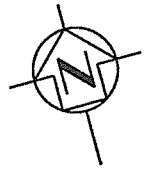

Assumed Pond El. 945.0

PLANE B/346

PLANE A/346

PLANE C/347

PLANE E/347

Stage 5 Main Embankment Crest El. 951.0

Chimney Drain

S.O.L.

Perimeter Embankment (see Drg. 338)

Main Embankment

Existing Upstream Toe Drain Outlet Pipe

S.O.L.

PLANE B/346 (Ch. 22 + 40)

PLANE A/346 (Ch. 20 + 00)

PLANE C/347 (Ch. 18 + 50)

PLANE E/347 (Ch. 17 + 60)

Main Embankment Seepage Collection Pond

Drain Monitoring Sump

Limit of Surveyed Topography

South Embankment (see Drg. 340)

Main Embankment

Boatjack-Morehead Connector

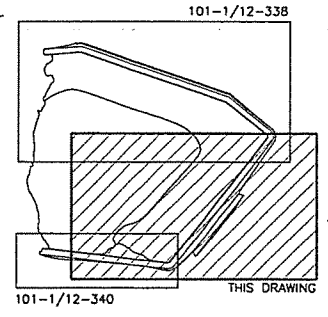

KEY PLAN

NOTES

1. Piezometers are vibrating wire type, SINCA Model 52611030 and RST Model 45005-0100 with a pressure rating of 100 psi or equivalent, connected to a readout panel via standard non-vented direct burial cable.

NOT FOR CONSTRUCTION

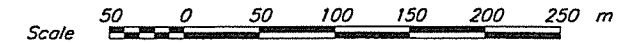

LEGEND

- GW96-9 Groundwater Monitoring Well
- A1-PE1-01 Previously installed Piezometer
- SI01-1 Existing Inclinator

DISCLAIMER

THIS DRAWING WAS PREPARED BY KNIGHT PIESOLD LTD. FOR THE ACCOUNT OF THE CLIENT LISTED ON THIS DRAWING. THE MATERIAL ON IT REFLECTS KNIGHT PIESOLD'S BEST JUDGMENT IN THE LIGHT OF THE INFORMATION AVAILABLE TO IT AT THE TIME OF PREPARATION. ANY USE WHICH A THIRD PARTY MAKES OF THIS DRAWING, OR ANY RELIANCE ON OR DECISIONS TO BE MADE BASED ON IT, ARE THE RESPONSIBILITY OF SUCH THIRD PARTIES. KNIGHT PIESOLD ACCEPTS NO RESPONSIBILITY FOR DAMAGES, IF ANY, SUFFERED BY THE THIRD PARTY AS A RESULT OF DECISIONS MADE OR ACTIONS BASED ON THIS DRAWING. COPIES RESULTING FROM ELECTRONIC TRANSFER OR REPRODUCTION OF THIS DRAWING ARE UNCONTROLLED AND MAY NOT BE THE MOST RECENT REVISION OF THIS DRAWING.

Knights Piesold CONSULTING

MOUNT POLLEY MINING CORPORATION

MOUNT POLLEY MINE

TAILINGS STORAGE FACILITY EXISTING INSTRUMENTATION MAIN EMBANKMENT PLAN

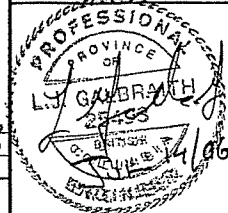

| | |
|-----|---|
| 347 | INSTRUMENTATION - PLANES C AND E |
| 346 | INSTRUMENTATION - PLANES A AND B |
| 340 | INSTRUMENTATION - SOUTH EMBANKMENT - PLAN |
| 338 | INSTRUMENTATION - PERIMETER EMBANKMENT - PLAN |

| REV. | DATE | DESCRIPTION | DESIGN | DRAWN | CHK'D | APP'D |
|------|----------|-------------------------------|--------|-------|-------|-------|
| 0 | 26MAY'06 | ISSUED FOR STAGE 5 PERMITTING | EER | WAL | BIS | KJB |

| REV. | DATE | DESCRIPTION | DESIGN | DRAWN | CHK'D | APP'D |
|------|------|-------------|--------|-------|-------|-------|
| | | | | | | |

| | | |
|------------------------|-------------|----------|
| PROJECT/ASSIGNMENT NO. | DRAWING NO. | REVISION |
| VA101-1/12 | 336 | 0 |

XREF FILE : Topo2004_ Features

CAD FILE: M:\101\06001\2\VA\Docs\Stage5\336.dwg 1:2500 Plot: 1-1 (P5) June 8, 2006 lam

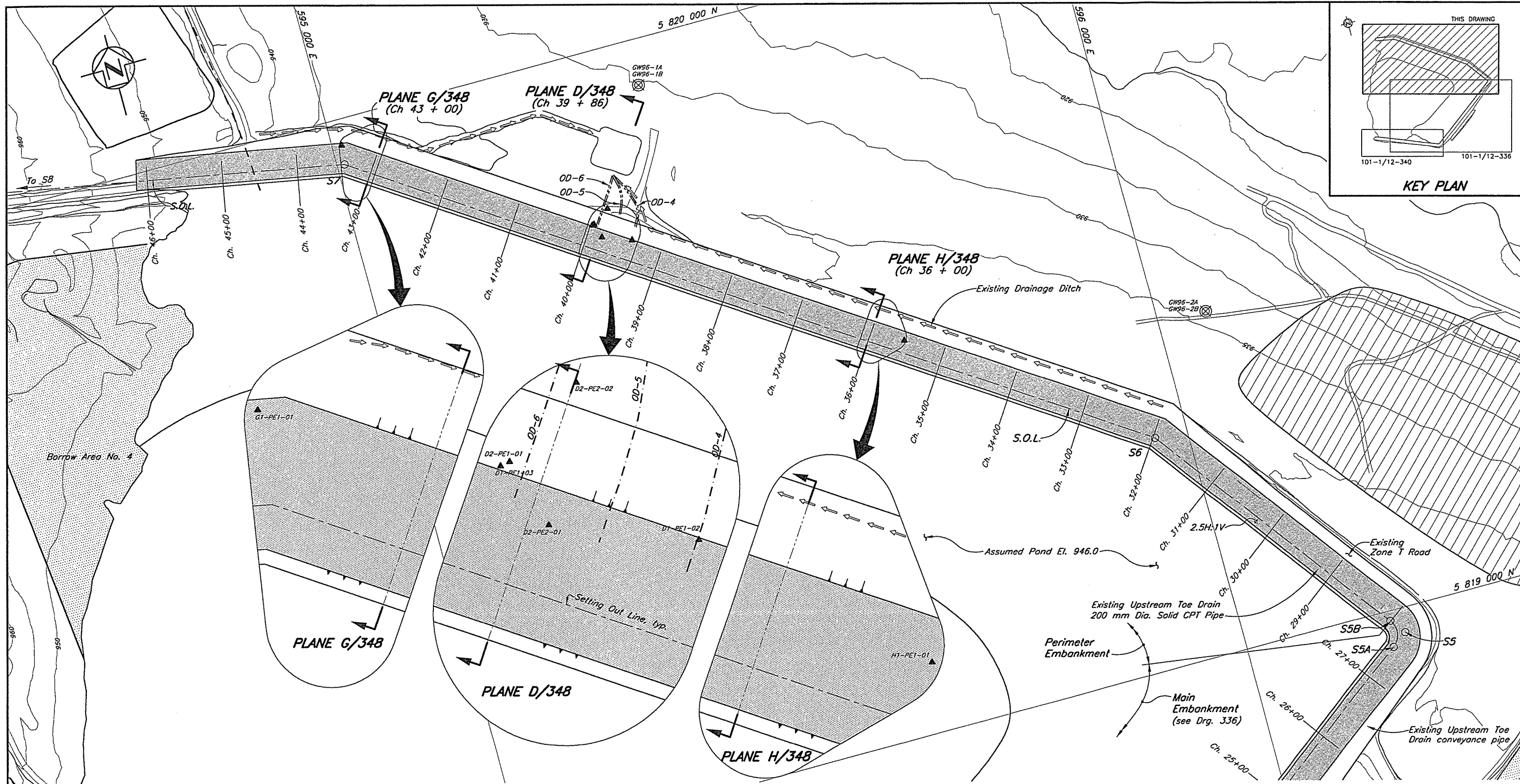

LEGEND

- ⊗ GW95-9 Groundwater Monitoring Well
- ▲ A1-PE1-01 Previously installed Piezometer

NOTES

1. Chainage defined by Setting Out Point S1 at Ch. 5+00.
2. Topography generated from points and break lines provided by MPMC on July 20, 1999. Topography outside the TSF area is from 1997 flyover.
3. Piezometers are vibrating wire type, SINCA Model 52611030 and RST Model 45005-0100 with a pressure rating of 100 psi or equivalent, connected to a readout panel via standard non-vented direct burial cable.

NOT FOR CONSTRUCTION

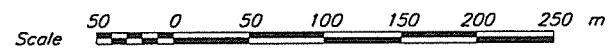

| DRG. NO. | DESCRIPTION |
|----------|---|
| 348 | INSTRUMENTATION - PLANES D, G AND H |
| 340 | INSTRUMENTATION - SOUTH EMBANKMENT - PLAN |
| 336 | INSTRUMENTATION - MAIN EMBANKMENT - PLAN |

| REV. | DATE | DESCRIPTION | DESIGN | DRAWN | CHK'D | APP'D |
|-----------|------|-------------|--------|-------|-------|-------|
| REVISIONS | | | | | | |

| REV. | DATE | DESCRIPTION | DESIGN | DRAWN | CHK'D | APP'D |
|-----------|----------|-------------------------------|--------|-------|-------|-------|
| 0 | 26MAY'06 | ISSUED FOR STAGE 5 PERMITTING | EER | WAL | BS | KJB |
| REVISIONS | | | | | | |

PROFESSIONAL ENGINEER
 L. J. GALBRAITH
 25493
 BRITISH COLUMBIA
 ENGINEER 4106

Knight Piésold
CONSULTING

MOUNT POLLEY MINING CORPORATION

MOUNT POLLEY MINE

**TAILINGS STORAGE FACILITY
EXISTING INSTRUMENTATION
PERIMETER EMBANKMENT
PLAN**

| | | |
|---|---------------------------|----------------------|
| PROJECT/ASSIGNMENT NO. VA101-1/12 | DRAWING NO. 338 | REVISION 0 |
|---|---------------------------|----------------------|

REF FILE: Tps2004 - Features

DUO FILE: M:\101\00001\12\VA\Kncd\Draws\238\238.dwg June 8, 2006 1:25:00 Plot: 1 = 1 (P5) W:\CUMBER B.C.

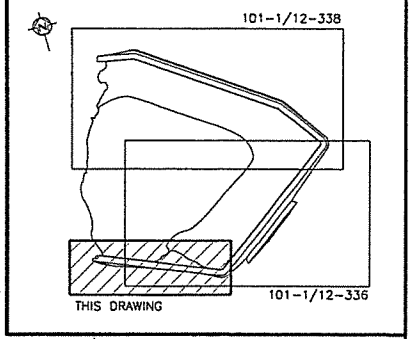
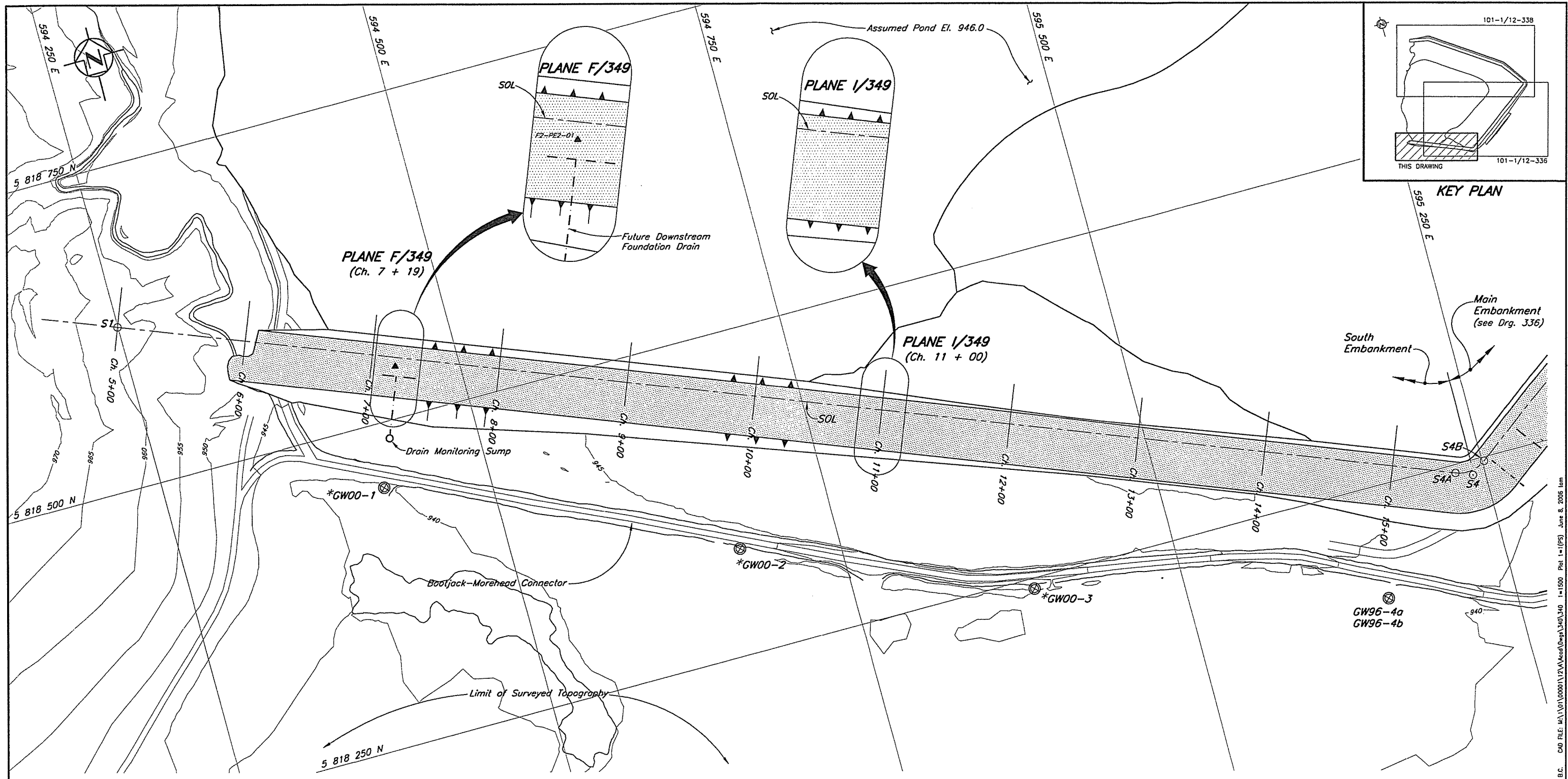

- LEGEND**
- ⊗ GW96-9 Groundwater Monitoring Well
 - ▲ A1-PE1-01 Previously installed Piezometer

- NOTES**
1. All dimensions in millimetres with elevations in metres, unless noted otherwise.
 2. No work was completed at the South Embankment during Stage 3B construction.
 3. Piezometers are vibrating wire type, SINCA Model 52611030 and RST Model 45005-0100 with a pressure rating of 100 psi or equivalent, connected to a readout panel via standard non-vented direct burial cable.

NOT FOR CONSTRUCTION



| DRG. NO. | DESCRIPTION | REV. | DATE | DESCRIPTION | DESIGN | DRAWN | CHK'D | APP'D |
|----------|--|------|------|-------------|--------|-------|-------|-------|
| 349 | INSTRUMENTATION - PLANES F AND I | | | | | | | |
| 338 | EXISTING INSTRUMENTATION - PERIMETER EMBANKMENT - PLAN | | | | | | | |
| 336 | EXISTING INSTRUMENTATION - MAIN EMBANKMENT - PLAN | | | | | | | |

| REV. | DATE | DESCRIPTION | DESIGN | DRAWN | CHK'D | APP'D |
|------|----------|-------------------------------|--------|-------|-------|-------|
| 0 | 26MAY'06 | ISSUED FOR STAGE 5 PERMITTING | EER | WAL | RB | KLB |

| REV. | DATE | DESCRIPTION | DESIGN | DRAWN | CHK'D | APP'D |
|------|------|-------------|--------|-------|-------|-------|
| | | | | | | |

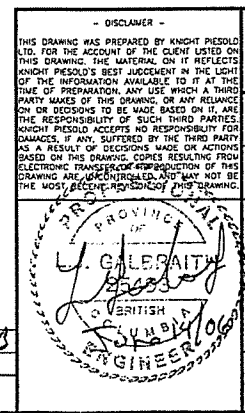

Knigh Piésold
CONSULTING

MOUNT POLLEY MINING CORPORATION

MOUNT POLLEY MINE

**TAILINGS STORAGE FACILITY
EXISTING INSTRUMENTATION
SOUTH EMBANKMENT
PLAN**

| | | |
|---|---------------------------|----------------------|
| PROJECT/ASSIGNMENT NO. VA101-1/12 | DRAWING NO. 340 | REVISION 0 |
|---|---------------------------|----------------------|

REF FILE: Topo2004 Features

VANCOUVER B.C. CAD FILE: M:\1\01\00001\1\2\VA\Kest\0\wp\340.dwg 1=1500 Plot 1=1 [PS] June 8, 2006 km

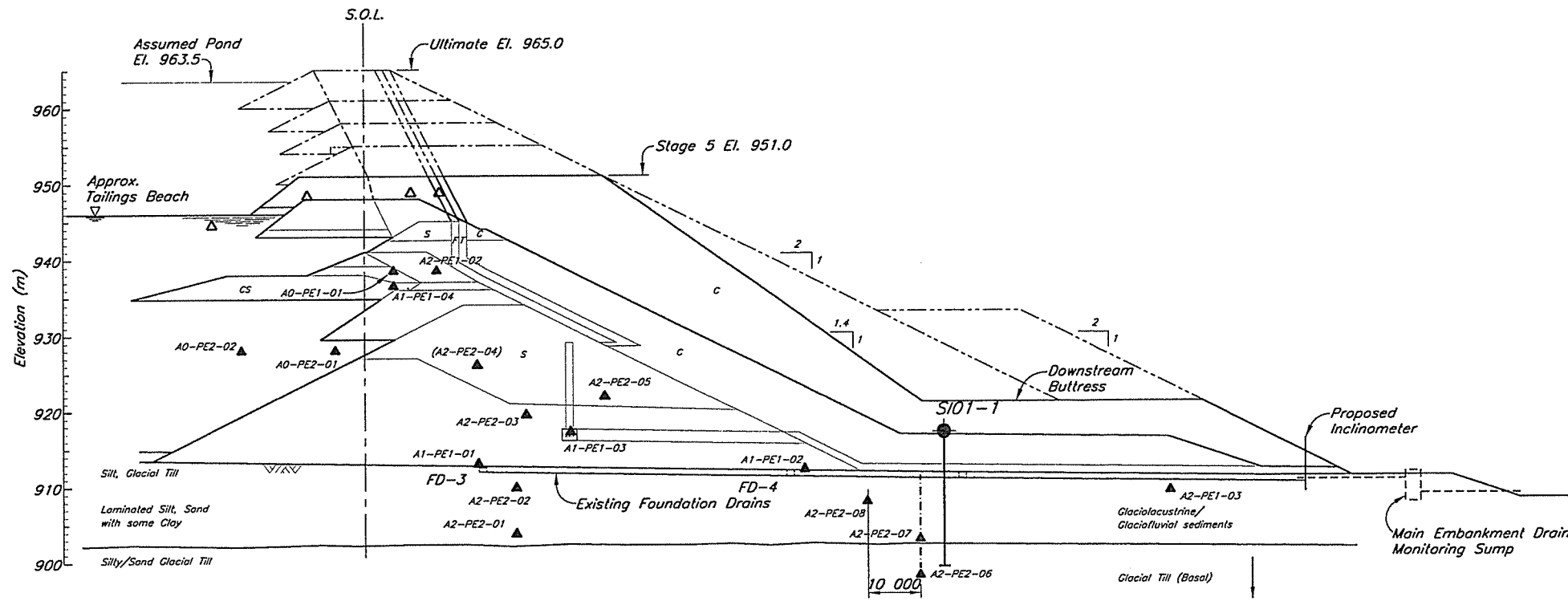

PLANE A/336

NOTES

1. Piezometers locations are approximate and may vary for individual Planes. Final location to be assessed during each design phase. Final configuration will be determined by the Engineer.

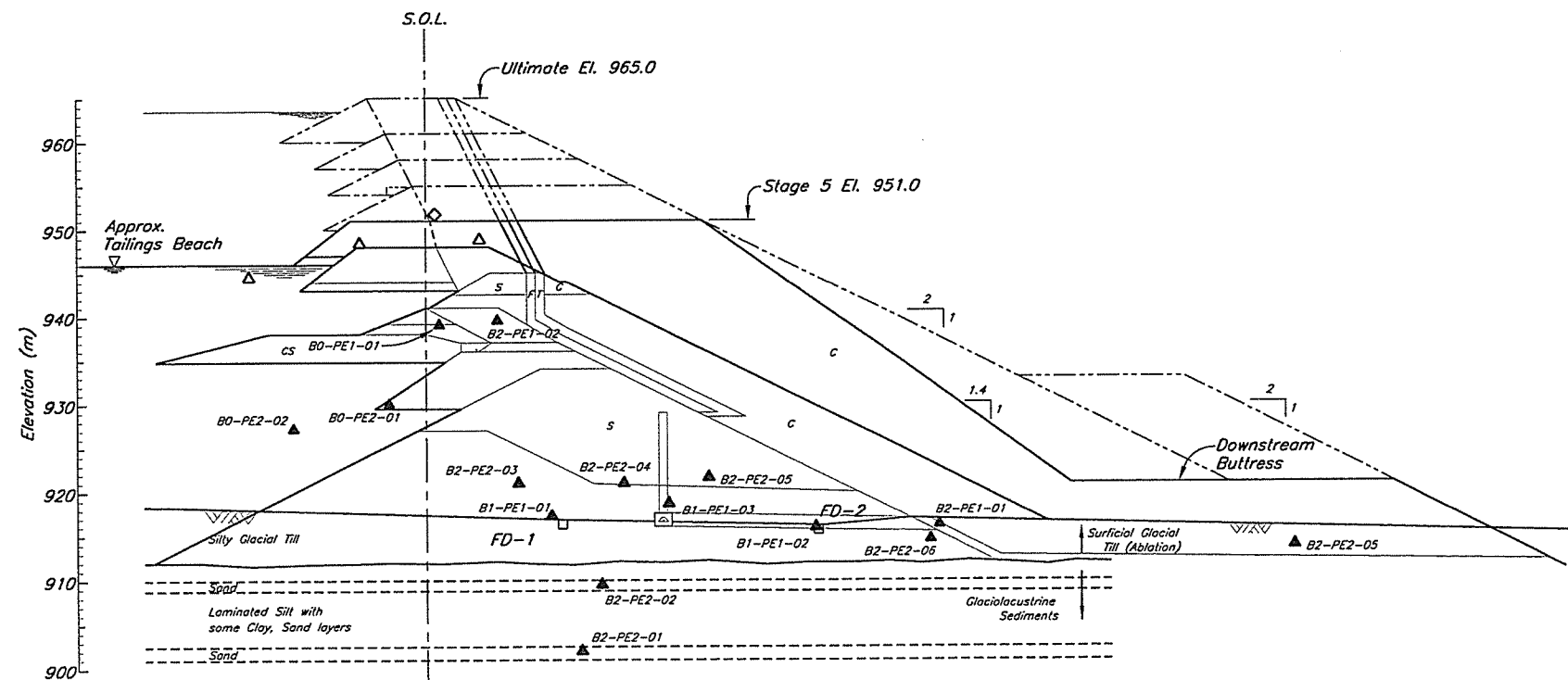

PLANE B/336

LEGEND

- Plane I.D. (A, B etc.)
- Area (0-Tailings, 1-Drain, 2-Embankment)
- Number I.D.
- Pressure Rating (1-Low, 2-High)
- Type of Instrumentation (PE-Piezometer electric, SM-Survey Monument)
- ▲ A2-PE2-03 Previously installed Piezometer
- ◆ A2-SM-07 Embankment Survey Monument
- △ Proposed Stage 5 Piezometer
- ◇ Proposed Stage 5 Survey Monument

NOT FOR CONSTRUCTION

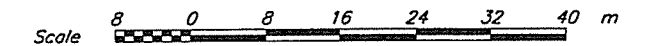

DISCLAIMER
THIS DRAWING WAS PREPARED BY KNIGHT PIESOLD LTD. FOR THE ACCOUNT OF THE CLIENT LISTED ON THIS DRAWING. THE MATERIAL ON IT REFLECTS KNIGHT PIESOLD'S BEST JUDGEMENT IN THE LIGHT OF THE INFORMATION AVAILABLE TO IT AT THE TIME OF PREPARATION. ANY USE WHICH A THIRD PARTY MAKES OF THIS DRAWING, OR ANY RELIANCE ON OR DECISIONS TO BE MADE BASED ON IT, ARE THE RESPONSIBILITY OF SUCH THIRD PARTY. KNIGHT PIESOLD ACCEPTS NO RESPONSIBILITY FOR DAMAGES, IF ANY, SUFFERED BY THE THIRD PARTY AS A RESULT OF DECISIONS MADE OR ACTIONS BASED ON THIS DRAWING. COPIES RESULTING FROM ELECTRONIC TRANSFER OR REPRODUCTION OF THIS DRAWING ARE UNCONTROLLED AND MAY NOT BE THE MOST RECENT REVISION OF THIS DRAWING.

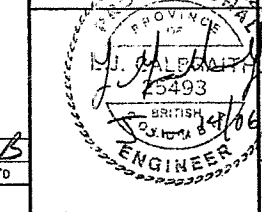

Knightsold CONSULTING

MOUNT POLLEY MINING CORPORATION

MOUNT POLLEY MINE

TAILINGS STORAGE FACILITY
STAGE 5 - INSTRUMENTATION
MAIN EMBANKMENT
PLANES A AND B

| | | |
|------------------------|-------------|----------|
| PROJECT/ASSIGNMENT NO. | DRAWING NO. | REVISION |
| VA101-1/12 | 346 | 0 |

| | | | | | | | | | | | | | | | |
|--------------------|--|------|------|-------------|--------|-------|-------|-----------|------|----------|-------------------------------|--------|-------|-------|-------|
| 347 | INSTRUMENTATION - MAIN EMBANKMENT - PLANES C AND E | REV. | DATE | DESCRIPTION | DESIGN | DRAWN | CHK'D | APP'D | 0 | 26MAY'06 | ISSUED FOR STAGE 5 PERMITTING | EER | NSD | BB | KIB |
| 336 | INSTRUMENTATION - MAIN EMBANKMENT - PLAN | | | | | | | | | | | | | | |
| DRG. NO. | DESCRIPTION | REV. | DATE | DESCRIPTION | DESIGN | DRAWN | CHK'D | APP'D | REV. | DATE | DESCRIPTION | DESIGN | DRAWN | CHK'D | APP'D |
| REFERENCE DRAWINGS | | | | REVISIONS | | | | REVISIONS | | | | | | | |

V:\PROJECTS\VA101\06001\2\VA101\Docs\Draws\246\246.dwg 1:400 Plot 1=1(PDF) June 8, 2006 km

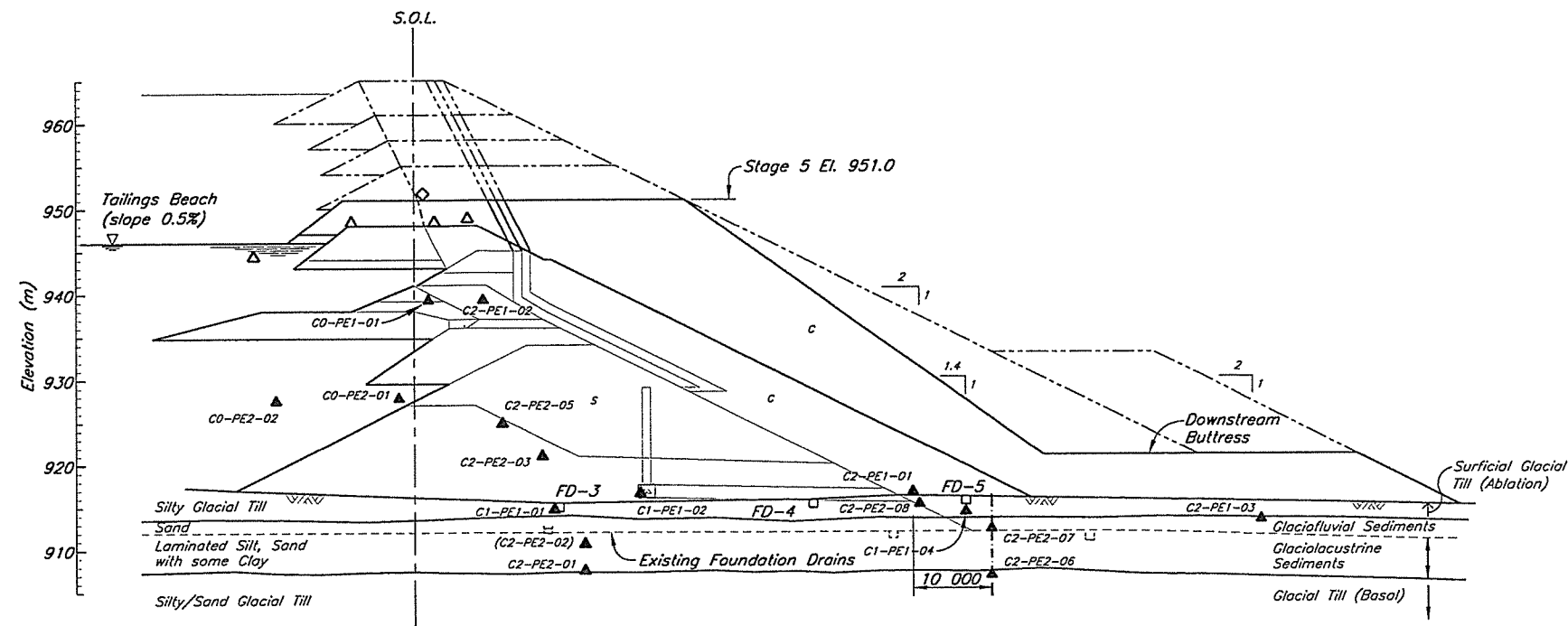

PLANE C/336

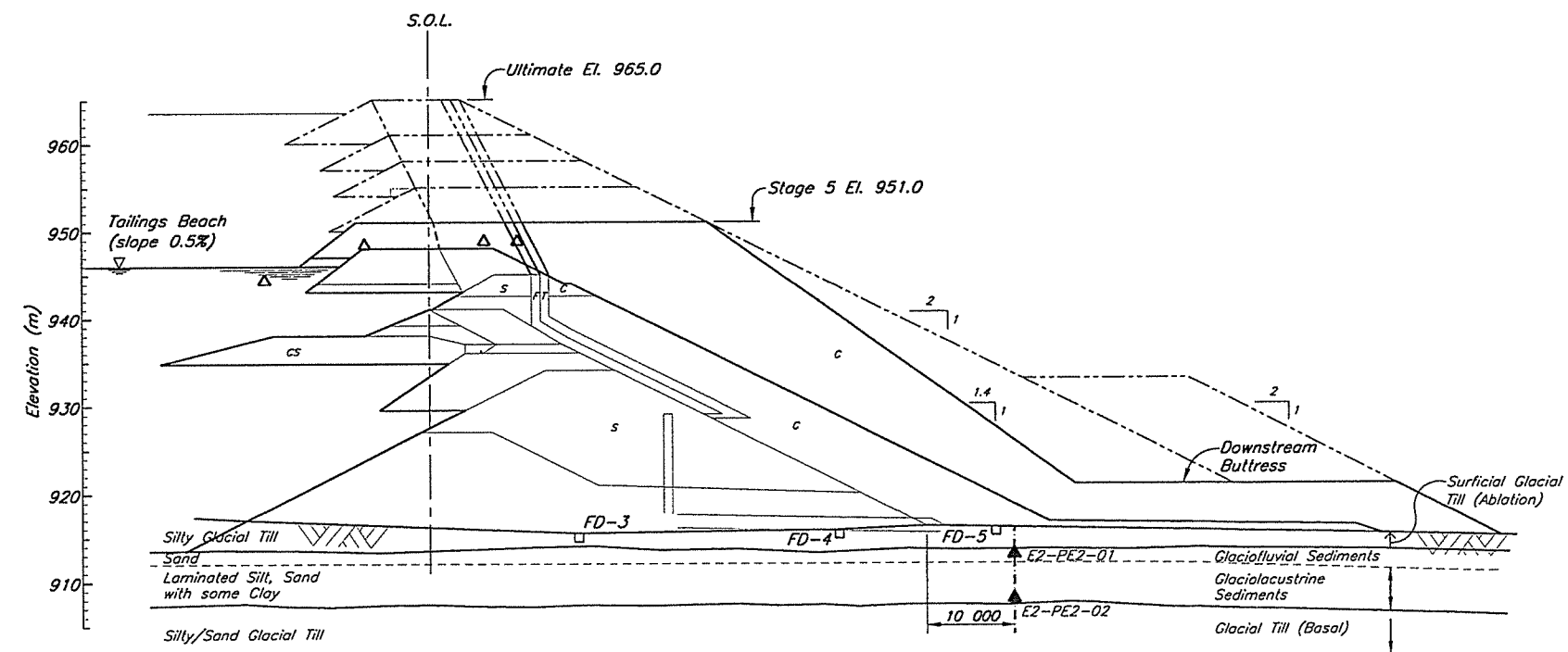

PLANE E/336

NOTES

1. Piezometers locations are approximate and may vary for individual Planes. Final location to be assessed during each design phase. Final configuration will be determined by the Engineer.

LEGEND

- Plane I.D. (A, B etc.)
- Area (0-Tailings, 1-Drain, 2-Embankment)
- A0-PE1-01—Number I.D.
- Pressure Rating (1-Low, 2-High)
- Type of Instrumentation (PE—Piezometer electric, SM—Survey Monument)
- A2-PE2-03 ▲ Previously installed Piezometer
- A2-SM-07 ◆ Embankment Survey Monument
- ▲ Proposed Stage 5 Piezometer
- ◆ Proposed Stage 5 Survey Monument

NOT FOR CONSTRUCTION

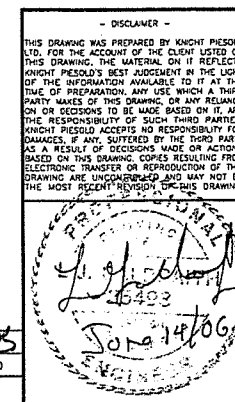
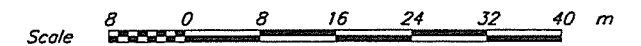

| | | |
|---|--------------------|---------------|
| Knights Piésold CONSULTING | | |
| MOUNT POLLEY MINING CORPORATION | | |
| MOUNT POLLEY MINE | | |
| TAILINGS STORAGE FACILITY STAGE 5 – INSTRUMENTATION MAIN EMBANKMENT PLANES C AND E | | |
| PROJECT/ASSIGNMENT NO. VA101-1/12 | DRAWING NO. 347 | REVISION 0 |

| DRG. NO. | DESCRIPTION | REV. | DATE | DESIGN | DRAWN | CHK'D | APP'D | REV. | DATE | DESCRIPTION | DESIGN | DRAWN | CHK'D | APP'D |
|--------------------|--|------|------|--------|-------|-------|-------|-----------|----------|-------------------------------|--------|-------|-------|-------|
| 346 | INSTRUMENTATION – MAIN EMBANKMENT – PLANES A AND B | | | | | | | 0 | 26MAY'06 | ISSUED FOR STAGE 5 PERMITTING | EER | NSD | BS | KJB |
| 336 | INSTRUMENTATION – MAIN EMBANKMENT – PLAN | | | | | | | | | | | | | |
| REFERENCE DRAWINGS | | | | | | | | REVISIONS | | | | | | |

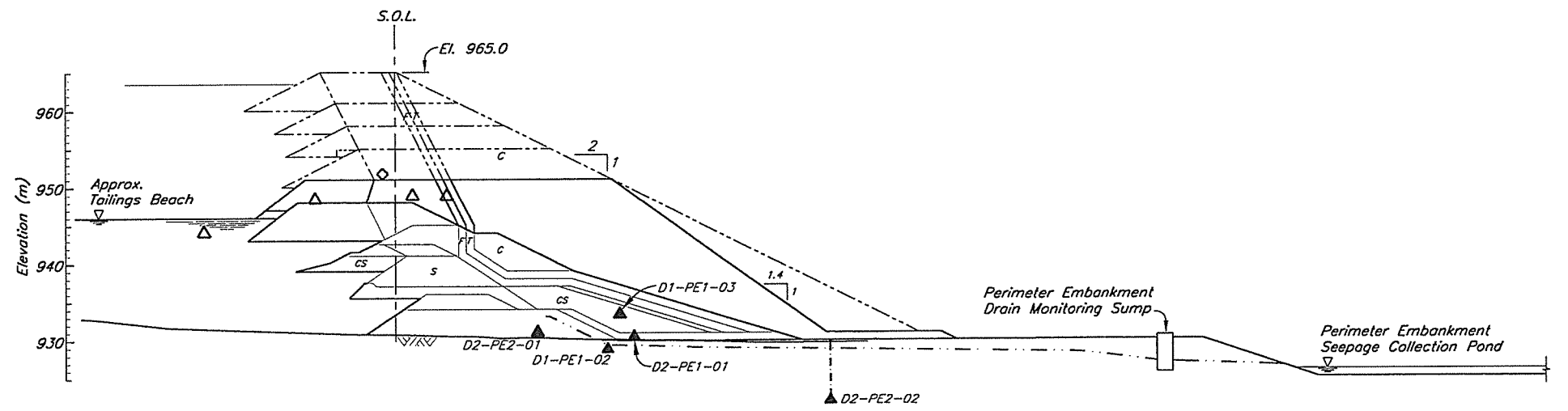

PLANE D/338

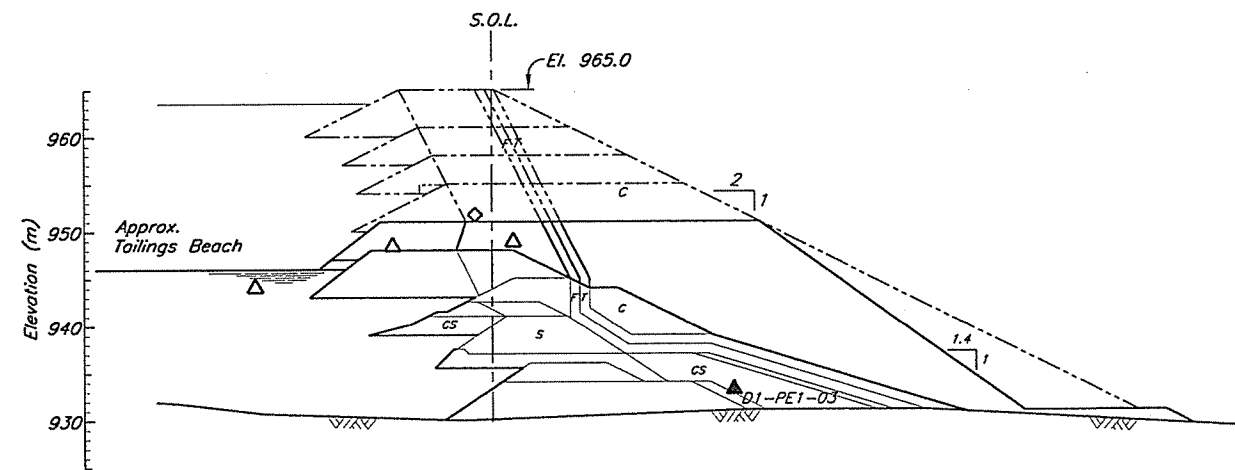

PLANE G/338

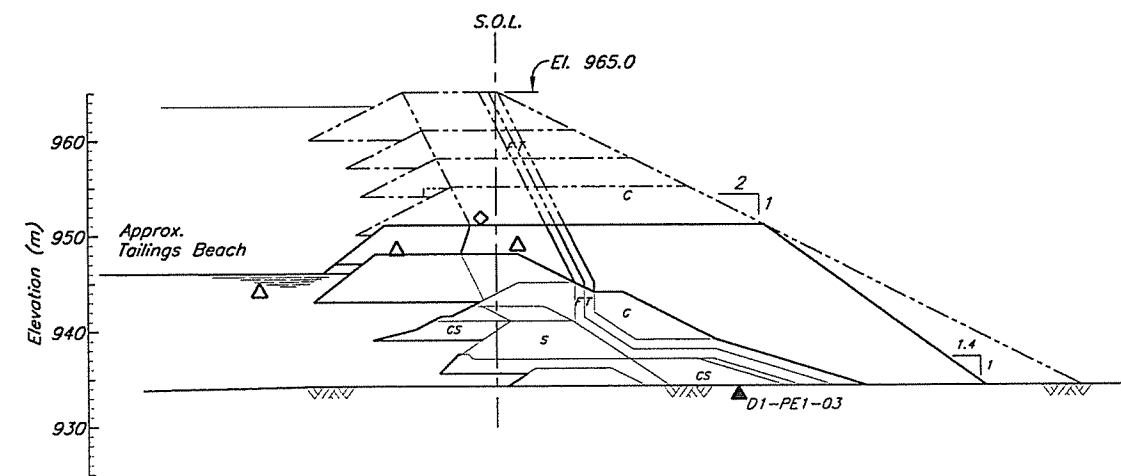

PLANE H/338

NOTES

1. Piezometers locations are approximate and may vary for individual Planes. Final location to be assessed during each design phase. Final configuration will be determined by the Engineer.

LEGEND

- Plane I.D. (A, B etc.)
- Area (0-Tailings, 1-Drain, 2-Embankment)
- A0-PE1-01 — Number I.D.
- Pressure Rating (1-Low, 2-High)
- Type of Instrumentation (PE-Piezometer electric, SM-Survey Monument)
- A2-PE2-03 ▲ Previously installed Piezometer
- A2-SM-07 ◆ Embankment Survey Monument
- ▲ Proposed Stage 5 Piezometer
- ◆ Proposed Stage 5 Survey Monument

NOT FOR CONSTRUCTION

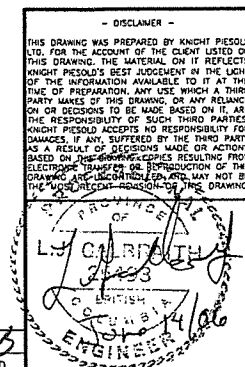
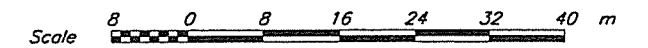

Knicht Piésold
CONSULTING

MOUNT POLLEY MINING CORPORATION

MOUNT POLLEY MINE

**TAILINGS STORAGE FACILITY
STAGE 5 - INSTRUMENTATION
PERIMETER EMBANKMENT
PLANES D, G AND H**

| | | |
|---|---------------------------|----------------------|
| PROJECT/ASSIGNMENT NO. VA101-1/12 | DRAWING NO. 348 | REVISION 0 |
|---|---------------------------|----------------------|

| | | | | | | | | | | | | | | | |
|--------------------|---|-----------|------|-------------|--------|-------|-------|-------|---|----------|-------------------------------|-----|-----|-------------|-------------|
| 338 | INSTRUMENTATION - PERIMETER EMBANKMENT - PLAN | REV. | DATE | DESCRIPTION | DESIGN | DRAWN | CHK'D | APP'D | 0 | 26MAY'06 | ISSUED FOR STAGE 5 PERMITTING | EER | NSD | [Signature] | [Signature] |
| REFERENCE DRAWINGS | | REVISIONS | | | | | | | | | | | | | |

C:\D:\FILE: 44\101\06001\12\A\Insta\Draw\348\348_1-400_Pla_1-1-(P5). June 8, 2006 10:06 AM

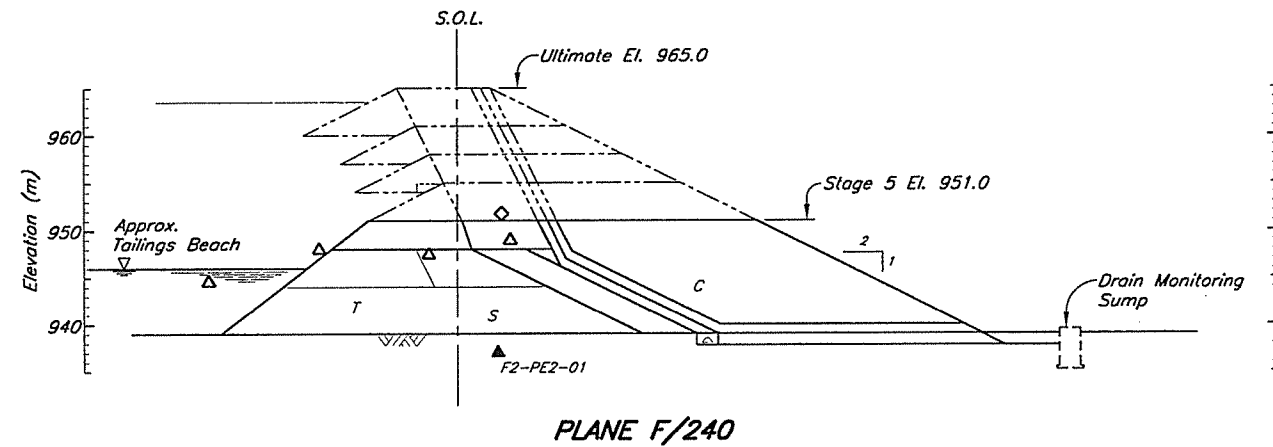

PLANE F/240

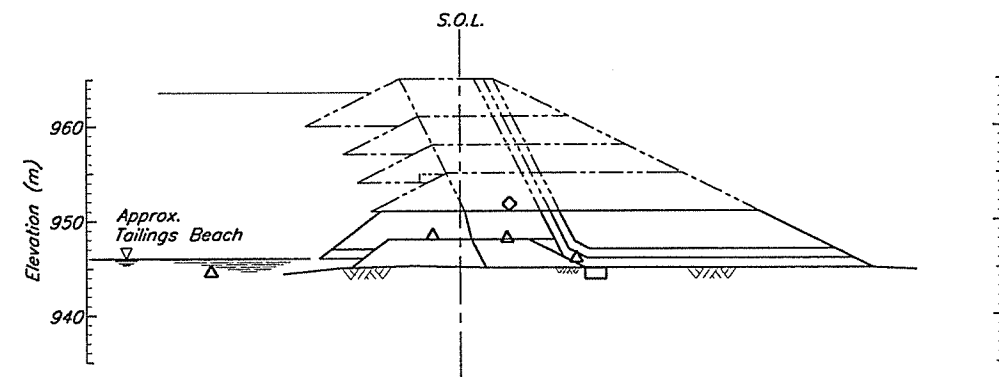

PLANE I/240

NOTE

1. Piezometers locations are approximate and may vary for individual Planes. Final location to be assessed during each design phase. Final configuration will be determined by the Engineer.

LEGEND

- Plane I.D. (A, B etc.)
- Area (0-Tailings, 1-Drain, 2-Embankment)
- A0-PE1-01—Number I.D.
- Pressure Rating (1-Low, 2-High)
- Type of Instrumentation (PE—Piezometer electric, SM—Survey Monument)
- A2-PE2-03 ▲ Previously installed Piezometer
- A2-SM-07 ◆ Embankment Survey Monument
- ▲ Proposed Stage 5 Piezometer
- ◆ Proposed Stage 5 Survey Monument

NOT FOR CONSTRUCTION

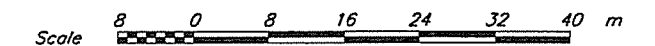

— DISCLAIMER —
 THIS DRAWING WAS PREPARED BY KNIGHT PIESOLD LTD. FOR THE ACCOUNT OF THE CLIENT LISTED ON THIS DRAWING. THE MATERIAL ON IT REFLECTS KNIGHT PIESOLD'S BEST JUDGEMENT IN THE LIGHT OF THE INFORMATION AVAILABLE TO IT AT THE TIME OF PREPARATION. ANY USE WHICH A THIRD PARTY MAKES OF THIS DRAWING OR ANY RELIANCE ON OR DECISIONS TO BE MADE BASED ON IT, ARE THE RESPONSIBILITY OF SUCH THIRD PARTIES. KNIGHT PIESOLD ACCEPTS NO RESPONSIBILITY FOR DAMAGES, IF ANY, SUFFERED BY THE THIRD PARTY AS A RESULT OF DECISIONS MADE OR ACTIONS BASED ON THIS DRAWING. COPIES RESULTING FROM ELECTRONIC TRANSFER OR REPRODUCTION OF THIS DRAWING ARE UNCONTROLLED AND MAY NOT BE THE MOST RECENT REVISION OF THIS DRAWING.

[Signature]
 26 May 14/06

Knights Piesold
 CONSULTING

MOUNT POLLEY MINING CORPORATION

MOUNT POLLEY MINE

TAILINGS STORAGE FACILITY
 STAGE 5 — INSTRUMENTATION
 SOUTH EMBANKMENT
 PLANES F AND I

| | | | | | | | | | | | | | | | |
|-----|---|------|------|-------------|--------|-------|-------|-------|------|------|-------------|--------|-------|-------|-------|
| 340 | INSTRUMENTATION — SOUTH EMBANKMENT — PLAN | REV. | DATE | DESCRIPTION | DESIGN | DRAWN | CHK'D | APP'D | REV. | DATE | DESCRIPTION | DESIGN | DRAWN | CHK'D | APP'D |
| | REFERENCE DRAWINGS | | | | | | | | | | | | | | |
| | | | | REVISIONS | | | | | | | REVISIONS | | | | |

| | | |
|------------------------|-------------|----------|
| PROJECT/ASSIGNMENT NO. | DRAWING NO. | REVISION |
| VA101-1/12 | 349 | 0 |

WACOUVER B.C. CAD FILE: M:\1\01\000001\2\WAcad\Draw\349.dwg 1-400 Plot 1-=[PS] June 8, 2006 tam

APPENDIX A

TECHNICAL PAPER ON
"MODIFIED CENTRELINE CONSTRUCTION OF TAILINGS EMBANKMENTS"

(Pages A1 to A7)

Modified Centreline Construction of Tailings Embankments

J.P. Haile & K.J. Brouwer

Knight Piésold Ltd.
Consulting Engineers
Suite 1400 - 750 West Pender Street
Vancouver, B.C., Canada
V6C 2T8

Abstract: A new approach to compacted fill embankments for tailings storage facilities has been developed which is seismically stable and minimizes the fill requirements, and hence costs, for embankment construction. Modified centreline construction is similar to conventional centreline construction but with the contact between the compacted fill and the tailings sloping slightly upstream. It is, however, different from upstream construction as the stability of the embankment relies on the relatively wide thickness of compacted fill at any elevation, is independent of the tailings strength and is inherently stable even with complete liquefaction of the tailings mass. The design approach significantly reduces the quantity of fill required for on-going raises compared to conventional centreline and downstream construction as on-going construction on the downstream face is not required. This also allows for reclamation of the downstream embankment face during operations. It has been successfully implemented at the Montana Tunnels Mine in Montana, where a final embankment height of over 100 metres is planned, and forms the basis for the tailings embankment design for new projects in Alaska and British Columbia, Canada. This paper describes the principal features of this construction technique, analytical procedures and case histories.

Key Words: mine tailings storage, embankment construction, waste reclamation, seismic stability

1. Introduction

The design of tailings facility embankments in seismically active areas, or for fine-grained, low strength tailings, has historically utilized conventional earth or rockfill embankments constructed as a full embankment section similar to a water retaining dam. No reliance is placed on the strength of the tailings and the embankment section is stable under all conditions of static and seismic loading. In some instances centreline construction using either the coarse fraction of the tailings or compacted fill is used to achieve the same design objectives.

Both of these approaches require a relatively large volume of fill material for the embankment section. With staged construction the volume of fill required for each incremental raise of the embankment crest gets larger as the height of the embankment increases, and requires construction on the downstream face of the embankment over the full height. This has the added disadvantage of not allowing reclamation of the downstream face to be carried out during mining operations. Staged construction of downstream and centreline embankments is shown schematically in Figure 1.

In most instances where these embankment cross-sections are required, upstream construction on the tailings mass itself would not be an appropriate alternative, either because of poor consolidation and/or drainage conditions within the tailings, potential liquefaction and low strength of the tailings. Upstream tailings embankments can only be constructed with fine grained tailings and in seismically active areas if proper measures are taken to ensure full consolidation and drainage of the tailings [1].

The modified centreline embankment, however, offers a cost effective alternative to downstream or centreline construction in areas of high seismic risk and for tailings with little or no strength. This paper describes the principal features of this construction technique, along with analytical procedures and case histories.

*3rd International Conference on Environmental
Issues and Waste Management in Energy and
Mineral Production, August, 1994. Perth,
Australia*

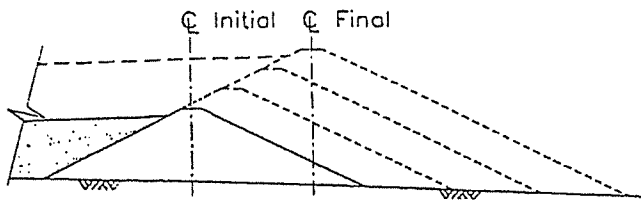

(i) Downstream

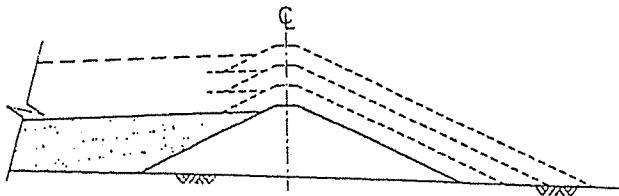

(ii) Centreline

Figure 1 Downstream and centreline embankments

2. Design Concept

The modified centreline cross-section is similar to a centreline cross-section but with the contact between the embankment fill and the tailings sloping slightly upstream. It results in the minimum volume of embankment fill for an embankment that is stable under all conditions of static and seismic loading. Furthermore, on-going construction on the downstream face is not required and reclamation can be carried out during operations. A schematic cross-section through a modified centreline embankment is shown on Figure 2.

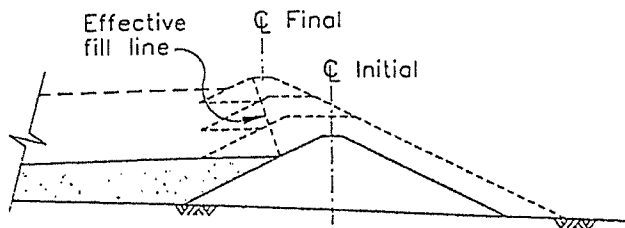

Figure 2 Modified centreline embankment

The modified centreline embankment achieves its stability from the relatively wide thickness of compacted fill at any elevation, and is independent of the strength of the tailings. The embankment is designed to be stable even if the tailings are fully liquefied and imposing both full fluid pressure and hydrodynamic loading on the upstream contact. The upstream contact remains stable even if the tailings are fully liquefied, when they would act as a dense fluid. The analogy is that of a slurry wall, where a dense

fluid such as bentonite mud can be used to support very deep excavations.

The construction technique does require some placing of fill on the tailings beach, and hence deposition of at least a portion of the tailings stream from the embankment face is required. Ideally, the beach should be at least strong enough to support the first lift of fill. This can be achieved on very soft tailings with the assistance of a geotextile separation layer. If the beach cannot support the first lift, then the tailings can be displaced using dumped rockfill.

Modified centreline tailings embankments can be designed as either water retaining structures or fully drained embankments. When designed to be water retaining, which is obviously a more severe loading condition than if fully drained, the water retaining zone, or core, should be located as far upstream as possible, in order to provide the necessary width of drained granular material downstream of the core for stability.

3. Stability and Deformation Analyses

Stability analyses of a modified centreline embankment can be considered under three separate headings:

- (i) Downstream stability,
- (ii) Upstream stability,
- (iii) Deformation Analyses.

Downstream Stability

Downstream stability can be analyzed initially as pseudo-static loading on the modified centreline portion of embankment only, i.e. that portion of the embankment above the full section. The forces acting on this section of the embankment are shown schematically on Figure 3.

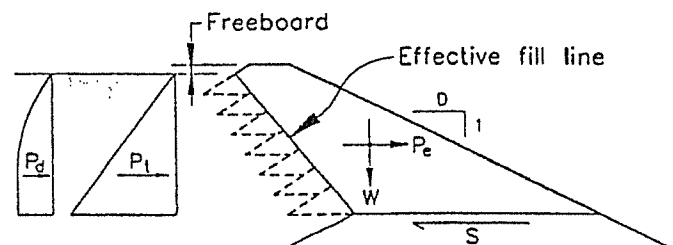

| SUMMARY OF LOADING CONDITIONS | |
|-------------------------------|----------------------------------|
| SYMBOL | DESCRIPTION |
| P_l | LIQUEFIED TAILINGS |
| P_d | HYDRODYNAMIC THRUST |
| P_e | EARTHQUAKE LOADING ON EMBANKMENT |
| W | WEIGHT OF EMBANKMENT |
| S | SHEAR RESISTANCE |

Figure 3 Downstream pseudo-static loading for stability analyses

In designing a modified centreline embankment the main variables to be considered in the geometry of the section are the height of the modified centreline portion, the downstream slope and the upstream contact slope between the fill and tailings.

The downstream slope will generally be dictated by the construction materials available, but the height of the modified centreline portion and the upstream contact slope will be a function of the seismicity of the site. The height of the modified centreline portion can be considered in terms of Critical Height (H_c), which is defined as that height at which the pseudo-static factor of safety is equal to 1.0 under a given acceleration. The relationships between H_c , acceleration and the upstream contact slope are shown on Figure 4, for a given set of assumptions and the loading conditions shown on Figure 3.

The concepts presented in Figure 4 can be used for an initial determination of H_c . However, it is important to realize that this critical height is not a

limiting height and only defines the height at which the critical acceleration for the embankment section k_c , is equal to the design acceleration for the site, a_{max} . Higher embankments, with a value of k_c less than a_{max} , can be safely designed but will be subject to some deformation during the earthquake shaking.

The modified centreline embankment must also incorporate suitable provisions for seepage control and for piping prevention. Since the embankment fill extends slightly over more compressible tailings materials, consolidation settlement may result in cracking of the embankment core zone. Therefore, the embankment design must incorporate suitable filter criteria and drainage provisions. In general, the tailings mass forms an ideal crack stopping filter medium so that piping failure is not a major consideration. Embankment stability can also be enhanced by incorporating drainage features such as chimney drains to reduce pore pressures within the structural zone of the embankment.

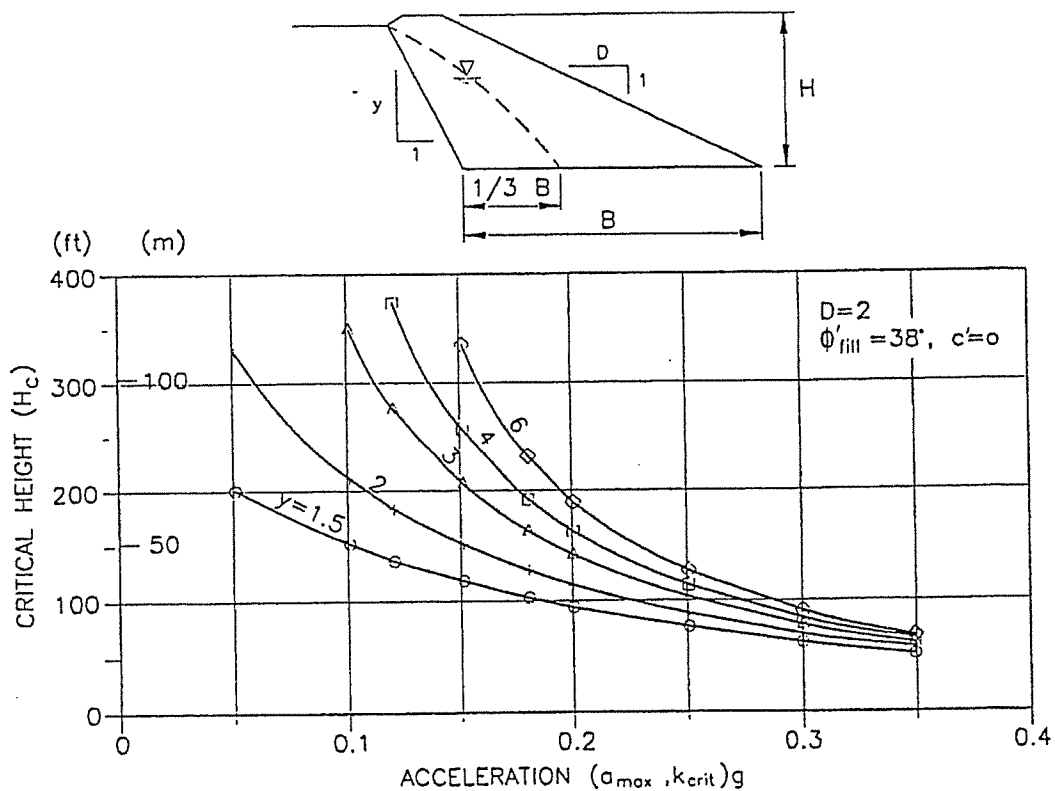
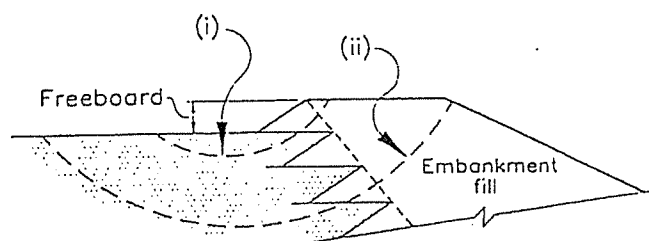

Figure 4 Relationship between critical height and acceleration

Upstream Stability

Upstream stability needs to consider two critical loading conditions: short-term loading on the tailings beach during embankment crest raising; and post-seismic upstream stability when the tailings would have only post liquefaction residual strength. In the first case, the principal concern is safety, whereas for the second case the principal concern is for failures causing loss of freeboard. Both cases need to be analyzed to determine the maximum allowable freeboard, which can then be related to flood storage requirements (Figure 5). In both analyses the appropriate strength characteristics of the tailings need to be known, in addition to those of the embankment fill materials.



- (i) Short term construction.
Tailings strength, $c_u/p' \approx 0.2 - 0.3$
- (ii) Post earthquake loss of freeboard.
Tailings residual strength, $c_u/p' \approx 0.1 - 0.2$

Figure 5 Upstream stability loading cases to determine maximum freeboard

Deformation Analyses

Deformation analyses can be carried out using the simplified procedures of Newmark [2] and Makdisi and Seed[3]. The analyses compare the critical acceleration k_c , with the site design acceleration, a_{max} , and compute displacements using empirical relationships and case history data from conventional water retaining dams. Modification of the amplitude of the ground acceleration as it propagates up through the embankment can be determined using the SHAKE [4] program. Similarly, the value of k_c at any elevation in the embankment can be determined from standard stability analysis programs. In order to compensate for the geometry of the modified centreline embankment and uncertainties in the mode of deformation, the largest value of acceleration determined from SHAKE can be used together with the smallest value of k_c to compute potential deformations.

A pseudo-dynamic finite element displacement analysis has been developed by Byrne *et al* [5,6]. This analysis can be used to determine deformations under both upstream and downstream earthquake loading, and to define the location and magnitude of the largest deformations. In general it predicts deformations

somewhat larger than those from the simplified Newmark analyses using the extreme values.

The stability analyses discussed above have only considered the more extreme loading conditions. In all embankment designs, all loading cases must be analyzed using relevant material parameters to ensure that acceptable factors of safety exist for each loading case.

4. Case Histories

Montana Tunnels Mine, Montana, USA.

The Montana Tunnels Mine is an open pit operation which involves processing gold, lead, zinc and silver ore at a rate of approximately 13,700 tonnes per day. The mine has been operating since 1987. Total mineable reserves from inception of mining have recently been expanded from 38 to 62 million tonnes.

The original tailings embankment was designed using a downstream method of construction for the annual staged expansions[7]. The compacted rockfill embankment layout was modified in 1990, when ongoing expansions were constructed using the modified centreline method in order to minimize fill quantities and preserve a downstream process water pond[8]. The modified centreline section was changed again in 1993 to enable expansion of the tailings impoundment to provide storage for the increased ore reserves. The embankment is presently designed to reach a maximum ultimate height of 105 metres. A schematic cross-section through the embankment is shown on Figure 6.

The redesign of the modified centreline embankment in 1993 included an extensive site investigation program which incorporated drilling, sampling, standard penetration testing, seismic piezocone testwork and installation of vibrating wire piezometers. A line of wick drains was installed along the tailings beach to enhance drainage into the free-draining embankment. A second wick drain program[9] was also completed within the tailings impoundment to dissipate excess pore pressures, accelerate consolidation and enhance seismic stability.

The stability assessment for the embankment included conventional limit equilibrium analyses for static, pseudo-static and post-earthquake conditions. Additional pseudo-dynamic finite element analyses, using the procedure described by Byrne *et al*[5], were also used to evaluate potential embankment deformations for a maximum credible earthquake with a peak horizontal ground acceleration of 0.22 g. The analysis includes both the inertia forces from the earthquake as well as the softening effect of the soil during cyclic loading. The fifth modified centreline embankment raise will be completed at the Montana Tunnels Mine during 1994, with annual expansions planned through 2001.

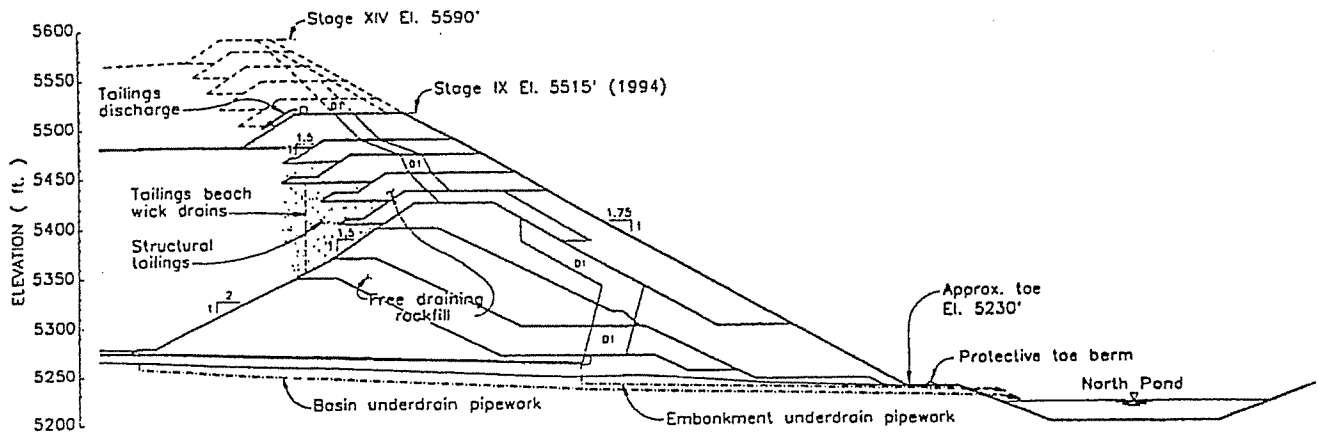

Figure 6 Typical section through Montana Tunnels embankment

Kensington Venture, Alaska, USA

The Kensington Project is a proposed underground gold mine located 40 miles north of Juneau, Alaska, on the east side of the Lynn Canal. The mine will require construction of a 89 metre high dam to contain the tailings from the mining operations. The dam is to be constructed in stages using compacted earthfill and rockfill and a modified centreline arrangement. The project is located in an area of high potential seismicity and earthquake-induced liquefaction of the tailings is possible. The stability of the top portion of the dam and the potential displacements resulting from earthquake loading are therefore of extreme importance. A cross-section through the proposed final embankment is shown on Figure 7.

Conventional limit equilibrium and Newmark analyses, including hydrodynamic loading from the

liquefied tailings, indicate that the embankment is stable and deformations would be very small. Deformation analyses were also carried out using the pseudo-dynamic finite element procedure developed by Byrne *et al* [5]. The analysis allows both the inertia forces from the earthquake as well as the softening effect of the liquefied soil to be considered.

Peak horizontal ground accelerations ranging from 0.2 g to 0.6 g were considered with corresponding peak ground velocities of 0.2 and 0.6 metre/second. The predicted peak displacements of the crest of the dam are 0.48 metre horizontal and 0.09 metre vertical. The maximum movement of the dam predicted from the Newmark analysis using the same soil strengths was 0.14 metres.

The Kensington Venture is currently in the final stages of permitting.

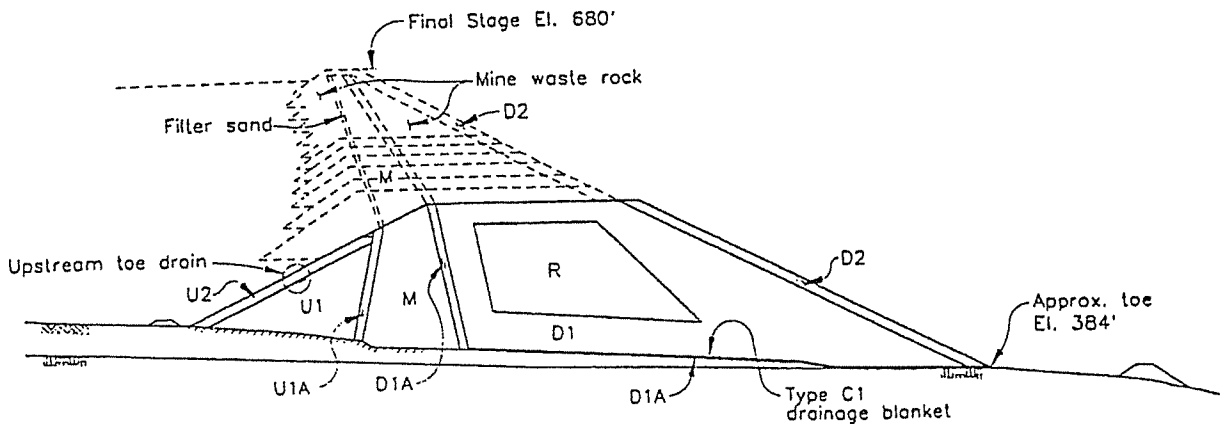

Figure 7 Typical section through Kensington embankment

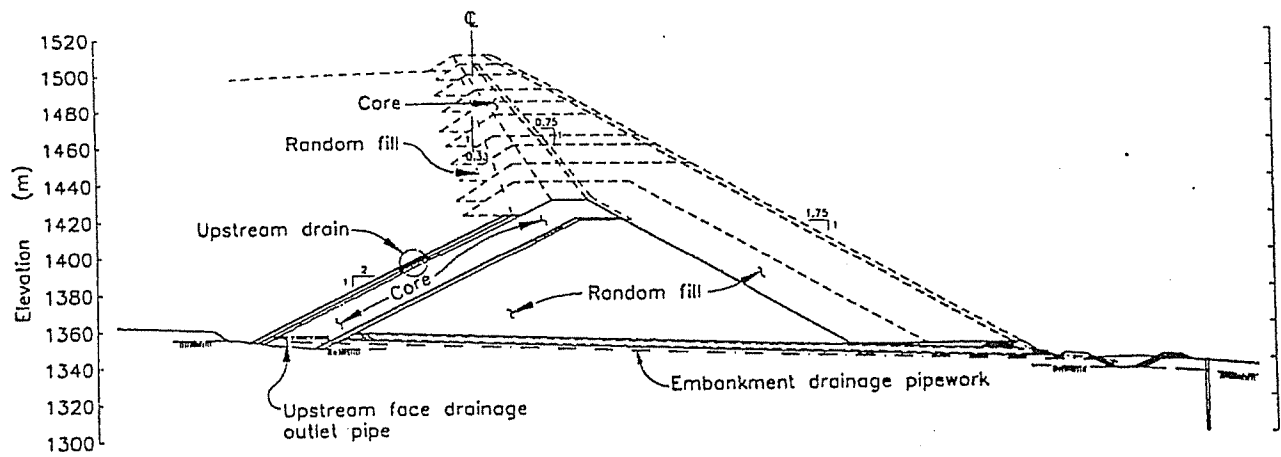

Figure 8 Typical section through Kemess South embankment

Kemess South Project, B.C., Canada

The Kemess South Project, situated in north central British Columbia, is presently in the final stages of permitting and is scheduled for development in 1995. A total reserve of 220 million tonnes of gold and copper ore will be processed at a rate of 40,000 tonnes per day. The project will include the staged construction of a compacted earthfill tailings embankment using the modified centreline technique to an ultimate height of 150 metres. A schematic embankment section is shown on Figure 8.

The project site is situated in an area of low seismicity and conventional pseudo-static limit equilibrium analyses indicate an adequate factor of safety against embankment deformation. The modified centreline embankment section was selected in order to minimize the quantity of fill required for staged expansions, and thus reduce on-going capital expenditures. Also, the downstream face of the embankment will be incrementally revegetated to minimize environmental impacts during operations and to reduce post-closure reclamation requirements.

5. Conclusions

The modified centreline embankment provides the least cost compacted fill embankment for tailings storage facilities in areas of high seismicity and for low strength tailings. These embankments are intrinsically stable under earthquake loading even with the tailings fully liquified. They can be constructed in stages using standard mining equipment and overburden materials from on-going mining operations. After the initial one or two stages no further construction is required on the downstream face, which allows for on-going reclamation during operations.

The modified centreline design has been successfully implemented at the Montana Tunnels Mine

in Montana, where a final embankment height of over 100 metres is planned. A detailed design has been developed for the Kensington Venture in Alaska and is in the final stages of the review process. Designs for new projects in B.C. and elsewhere in North America are currently at the development stage.

References

1. Haile, J.P. and Kerr, T.F., 1989. "Design and Operation of the Myra Falls Tailings Disposal Facility." Vancouver Geotechnical Society's 4th Annual Symposium on Geotechnical Aspects of Tailings Disposal and Acid Mine Drainage. May 26, 1989, Vancouver, B.C.
2. Newmark, N.M., 1965. "Effects of Earthquakes on Dams and Embankments." *Geotechnique* 15: 139-160.
3. Makdisi, F.I. and Seed, H.B., 1977. "A Simplified Procedure for Estimating Earthquake Induced Deformations in Dams and Embankments." Report No. UCB-EERC-77/19, College of Engineering, University of California, Berkeley.
4. Schnabel, P.B., Lysmer, J. and Seed, H.B., 1972. "SHAKE - A Computer Program for Earthquake Response Analysis of Horizontally Layered Sites." Report No. EERC 72-12, University of California, Berkeley, California.
5. Byrne, P.M., Jitno, H., Haile, J., 1992. "A Procedure for Predicting the Seismic Response of Tailings Impoundments." First Canadian Symposium on Geotechnique and Natural Hazards. May 6-9, 1992, Vancouver, B.C.

6. Byrne, P.M, Jitno, H., Anderson, D.L, Haile, J., 1994. "A Procedure for Predicting Seismic Displacements of Earth Dams." Report No. XIII CSMFE, 1994, New Delhi, India/XIII CIMSTF, 1994, New Delhi.

7. Haile, J.P. and Brouwer, K.J., 1987. Design and Construction of the Montana Tunnels Tailings Disposal Facility: 89th Annual General Meeting of the Canadian Institute of Mining. May 3-7/87, Toronto, Ontario.

8. Brouwer, K.J., Weitz, T.J. and Haile, J.P., 1992. "Design and Operation of the Montana Tunnels Tailings Disposal Facility." Second International Conference on Environmental Issues & Management of Waste in Energy & Mineral Production. September 1 - 4, 1992, Calgary, Alberta.

9. Brouwer, K.J., Brown, B.S. and Stewart, D, 1994. "Tailings Consolidation Using Wick Drains." 3rd International Conference on Environmental Issues and Waste Management in Energy and Mineral Production, 1994. Perth, Australia.